

ST
MOMENTUM™

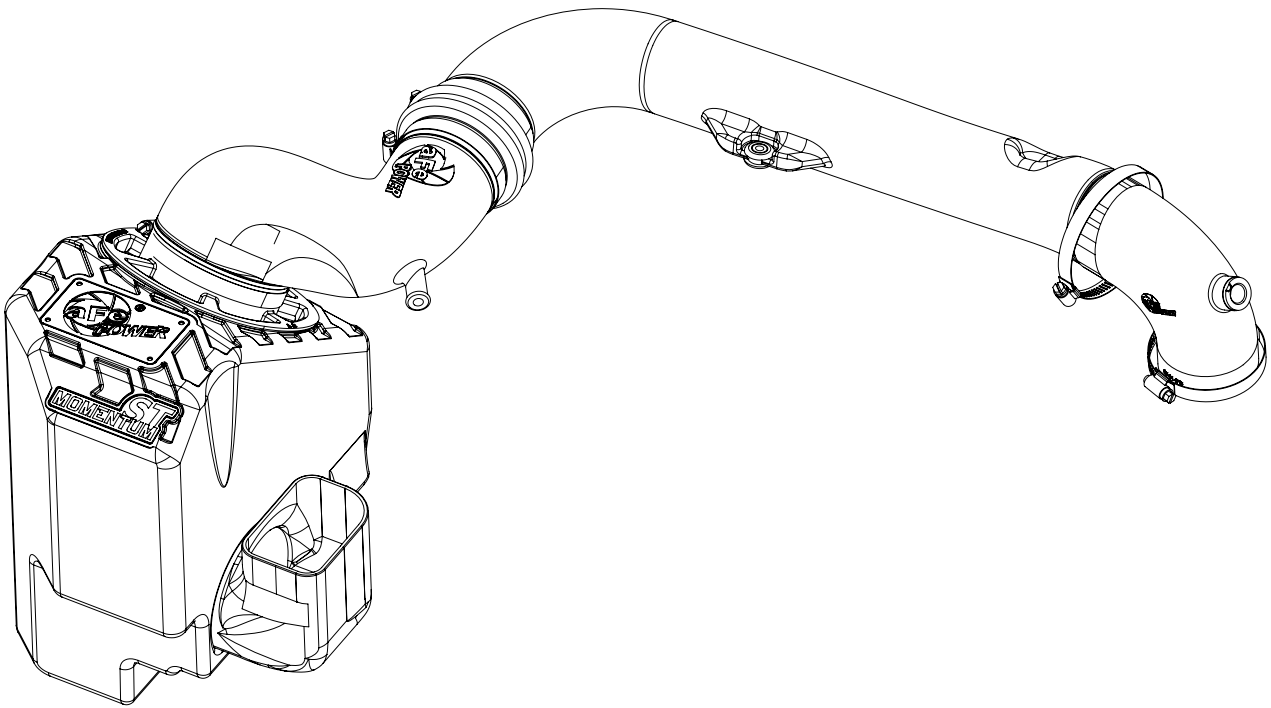

advanced FLOW engineering Momentum ST Intake System

Instruction Manual P/N: 51-46216 / 54-46216 / 75-46216

Make: **Jeep** Model: **Cherokee (KL)** Year: **2014-2018** Engine: **L4-2.4L**



- Please read the entire instruction manual before proceeding.
- Ensure all components listed are present.
- If you are missing any of the components, call customer support at 951-493-7100.
- Ensure you have all necessary tools before proceeding.
- Do not attempt to work on your vehicle when the engine is hot.
- Disconnect the negative battery terminal before proceeding.

Retain factory parts for future use.

| Label | Qty. | Description | Part Number |
|-------|------|----------------------------|-------------|
| A1 | 1 | Air Filter (Pro DRY S) | 21-90101 |
| A2 | 1 | Air Filter (Pro 5R) | 24-90101 |
| A3 | 1 | Air Filter (Pro-GUARD 7) | 72-90101 |
| B | 1 | Tube 1 of 2 | 05-01473B1 |
| C | 1 | Tube 2 of 2 | 05-01473B2 |
| D | 1 | Housing | 05-01469B2 |
| E | 1 | Air Inlet | 05-01473B3 |
| F | 1 | Fitting, Air Temp Sensor | 05-01454 |
| G | 1 | Coupling, Silicone Bellow | 05-01400 |
| H | 1 | Coupling, Silicone 90 Deg. | 05-01478 |
| I | 4 | Clamp, #048 | 03-50007 |
| J | 1 | Grommet, Rubber | 03-50076 |
| K | 1 | Spacer, Nylon 1/2" | 03-50120 |

Installation will require the following tools:

8mm & 10mm nut drivers, flat head screwdriver, ratchet with extension, U-joint, 7mm socket.

Note: Legal in California for use on race vehicles only. The use of this device on vehicles used on public streets or highways is strictly prohibited in California and others states that have adopted California emission regulations.

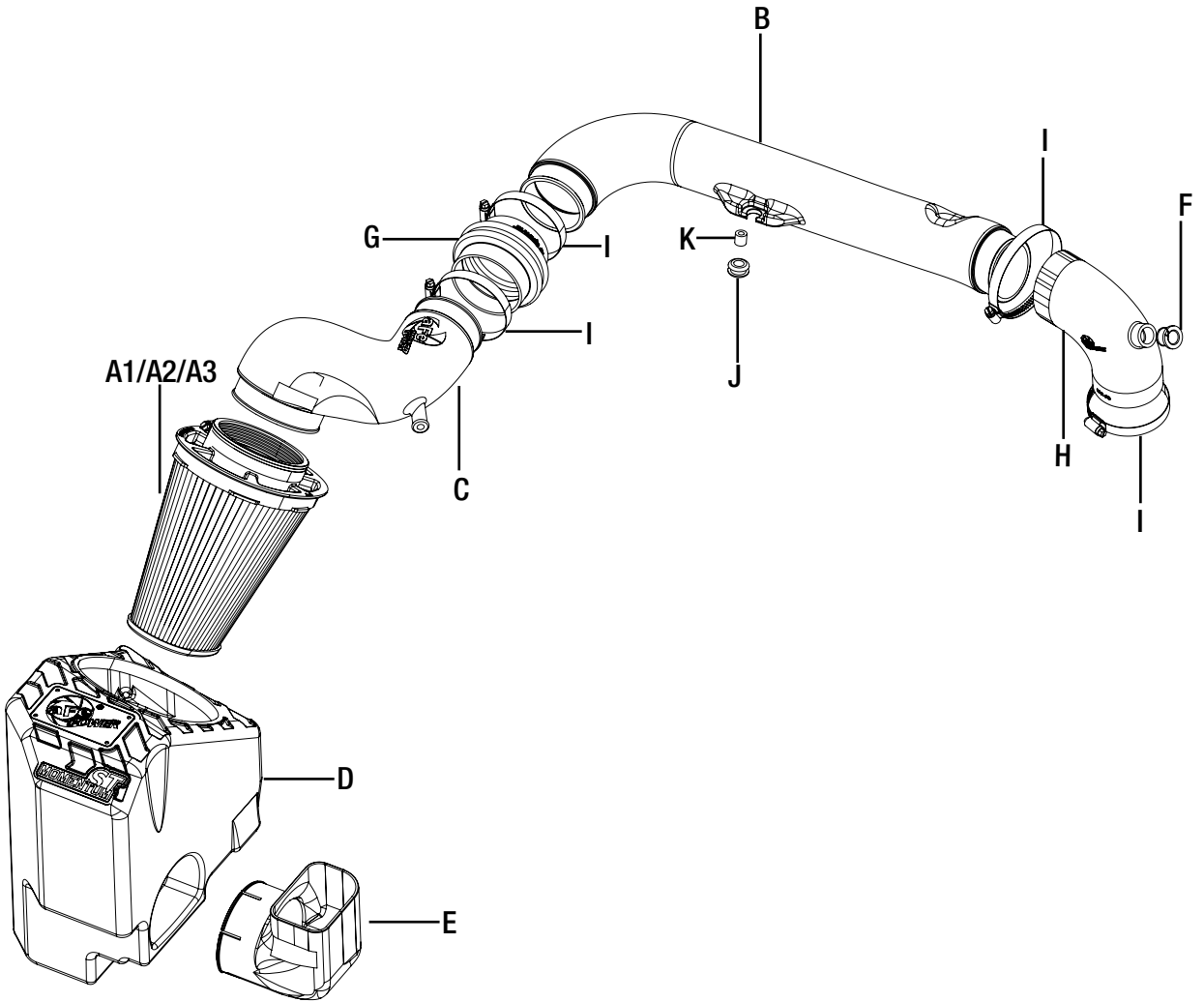



Figure A

Refer to Figure A for Step 1.

Step 1: Remove the engine cover ① by gently pulling up until it disengages from the mounting studs.

**Figure B****Refer to Figure B for Step 2.**

Step 2: Remove the front cowling of the vehicle by disengaging the 12 clips (2) using a flat head screw driver. Set all components aside for later use.

**Figure C****Refer to Figure C for Step 3.**

Step 3: Using a 10mm nut driver, remove the screw (3) securing the stock air scoop to the vehicle. Remove the air scoop by gently pulling up until it is removed from the stock airbox, then pulling towards the rear of the vehicle to disengage from the grommets. Set aside for later use



Figure D

Refer to Figure D for Steps 4-10.

Step 4: Using an 8mm nut driver, loosen the clamp on the stock airbox (4).

Step 5: Disconnect the stock vent tube (5) from the intake tube.

Step 6: Disconnect the temperature sensor wire harness (6).

Step 7: Using a 10mm nut driver, remove the support screw (7) from the stock intake tube and set aside.

Step 8: Using a panel clip removal tool, remove the clip on the rear of the stock plenum (8).

Step 9: Using a U-joint with a 7mm socket, loosen the clamp at the throttle body (9).

Step 10: Remove the stock intake tube by gently pulling up from the throttle body, then away from the stock airbox.

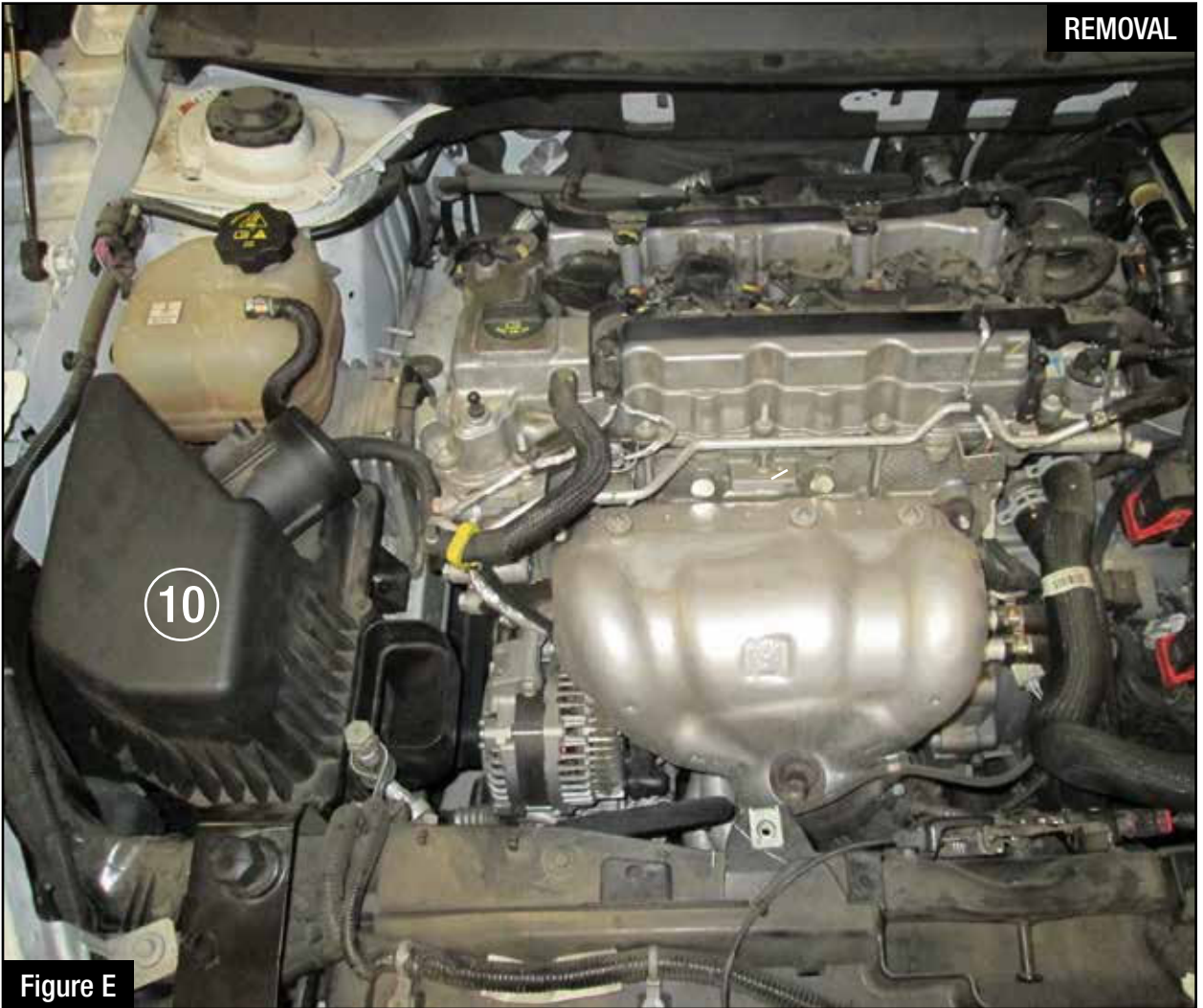
**Figure E****Refer to Figure E for Step 11.**

Step 11: Remove the stock airbox ⑩ by gently pulling straight up until all 3 grommets disengage. Set aside.

**Figure F****Refer to Figure F for Steps 12-13.**

Step 12: Transfer two rubber grommets (11) from the stock airbox to the aFe airbox in the upper mounting locations.

Step 13: Place the third grommet (12) into the metal mounting bracket on the inner fender of the vehicle.



Refer to Figure G for Step 14.

Step 14: Install the aFe air scoop inlet (13) into the aFe housing by inserting the cut side until it locks into place in the aFe housing.



INSTALL

Figure H

Refer to Figure H for Steps 15-16.

Step 15: Install the aFe airbox into the vehicle by lining up the three mounting grommets and gently applying pressure until the grommets lock into place.

Step 16: Install your aFe air filter into the airbox.



Figure I

Refer to Figure I for Step 17.

Step 17: Install the temperature sensor fitting (14) into the aFe elbow coupler (15) .



Figure J

Refer to Figure J for Step 18.

Step 18: Transfer the temperature sensor (16) from the stock intake tube into the temperature sensor fitting in the aFe elbow coupler.



Figure K

Refer to Figure K for Step 19.

Step 19: Install the aFe elbow coupler and clamp with the smaller side on the throttle body as shown. Do not tighten the clamp at this time.

INSTALL



Figure L

Refer to Figure L for Step 20.

Step 20: Install the supplied rubber grommet and insert into the longer aFe intake tube as shown.

**Figure M****Refer to Figure M for Step 21.**

Step 21: Install the longer aFe intake tube into the vehicle by inserting the oval end (17) with a clamp into the coupler on the throttle body, then using the 10mm screw removed in Step 7 to secure the tube to the support mount (18). Tighten both clamps on the elbow coupler using an 8mm socket and U-joint driver.



Figure N

Refer to Figure N for Step 22.

Step 22: Install the straight reducer aFe coupler (19) with one clamp onto the intake tube with the smaller end of the coupler on the tube. Tighten the clamp using an 8mm nut driver.

**Figure 0****Refer to Figure 0 for Step 23.**

Step 23: Install the smaller intake tube (20) with one clamp into the straight coupler and slide the opposite end into the air filter. Tighten both clamps using an 8mm nut driver.



Figure P

Refer to Figure P for Step 24.

Step 24: Reconnect the temperature sensor wire harness (21) and vent hose (22).

**Figure Q****Refer to Figure Q for Step 25.**

Step 25: Reinstall the stock air scoop (23) by lining up the front mounts with the grommets on the frame of the vehicle, then sliding the bottom end into the aFe air scoop inlet. Secure the scoop using the screw removed in Step 3.



Figure R

Refer to Figure R for Step 26.

Step 26: Reinstall the front cowling using the 12 clips removed in Step 2.



Figure S

Refer to Figure S for Step 27.

Step 27: Check that all clamps are snug, and all mounting screws are secure.



Figure T

Refer to Figure T for Step 28.

Step 28: Reinstall the engine cover by lining it up with the mounting studs and gently pressing down until it locks into place. Your installation is now complete! Thank you for choosing aFe POWER!

NOTE: Check all bolts, clamps, and connectors after 100-200 miles.



Page left blank intentionally

Page left blank intentionally



Pro DRY S Air Filter



P/N: 21-90101

Pro 5R Air Filter



P/N: 24-90101

Pro-GUARD 7 Air Filter



P/N: 72-90101

aFe POWER T-Shirt



P/N: 40-30441-B (S)
40-30442-B (M)
40-30443-B (L)
40-30444-B (XL)
40-30445-B (2XL)

Pro DRY S Restore Kit



P/N: 90-59999

Blue Squeeze Restore Kit



P/N: 90-50501

Gold Squeeze Restore Kit



P/N: 90-50500

Warranty

General Terms:

- aFe warrants their products to be free from manufacturer's defects due to workmanship and material.
- This warranty applies only to the original purchaser of the product and is nontransferable.
- Proof of purchase of the aFe product is required for all warranty claims.
- Warranty is valid provided aFe instructions for installation and/or cleaning were properly followed.
- Proper maintenance with regular inspections of product is required to insure warranty coverage.
- Damage due to improper installation, abuse, unauthorized repair or alteration is not warranted.
- Incidental or consequential damages or cost, including installation and removal of part, incurred due to failure of aFe product is not covered under this warranty.
- All warranty is limited to the repair and/or replacement of the aFe part. To request Return Goods Authorization ("RGA"), email RGA@afepower.com or call (951)493-7100. Upon receipt of the RGA, you must return the product to the address provided in the RGA, freight prepaid and accompanied with a dated proof of purchase and the RGA. Upon receipt of the defective product and upon verification of proof of purchase, aFe will either repair or replace the defective product within a reasonable time, not to exceed thirty days.

| Product Category | P/N Prefix | Warranty duration |
|----------------------------------|------------------------|--------------------------|
| Direct OE Replacement Filters | 10, 11, 30, 31, 71, 73 | Life of the vehicle |
| Racing Filters | 18 | 1 year |
| Universal | 21, 24, 72 | 2 years |
| Air Intake Systems | 50, 51, 54, 55, 75 | 2 years |
| Exhaust Systems | 49 | 2 years |
| Intercoolers & Intercooler Tubes | 46-2 | 2 years |
| Intake Manifolds | 46-1 | 2 years |
| Differential Cover | 46-7 | Life of the vehicle |
| Exhaust Manifolds | 46 | 2 years |
| Throttle Body Spacers | 46-3 | 2 years |
| Fluid Filters | 44 | 90 days |
| Pre-Filters | 28 | 2 years |
| Heavy Duty OE Replacement | 70 | 2 years |
| PowerSports OE Replacement | 81, 87 | 2 years |
| PowerSports Intake Systems | 85 | 2 years |

No other warranty expressed or implied applies nor is any person or advanced FLOW engineering authorized to assume any other warranty. Some States do not allow the exclusion or limitation of incidental or consequential damages or do not allow limitations on how long an implied warranty lasts, so the above limitations or exclusions may not apply to you. This warranty gives you specific legal rights, and you may also have other rights which vary from State to State.

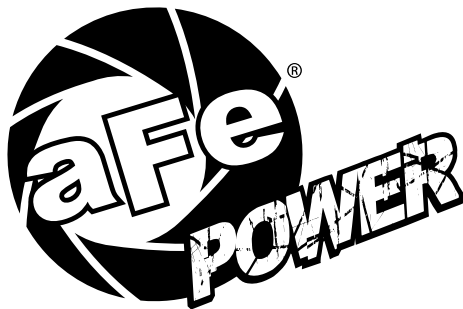

advanced FLOW engineering, inc.
252 Granite Street Corona, CA 92879
TEL: 951.493.7100 • TECH: 951.493.7134
E-Mail: Tech@aFepower.com