

advanced FLOW engineering

Quantum Cold Air Intake System

Instruction Manual P/N: 53-10017D / 53-10017R

Make: Jeep Model: Wrangler (JL) Year: 2018-2020 Engine: V6-3.6L

Make: Jeep Model: Gladiator (JT) Year: 2020-2021 Engine: V6-3.6L



- Please read the entire instruction manual before proceeding.
- Ensure all components listed are present.
- If you are missing any of the components, call customer support at 951-493-7185.
- Ensure you have all necessary tools before proceeding.
- Do not attempt to work on your vehicle when the engine is hot.



Retain factory parts for future use.

Label	Qty.	Description	Part Number
A1	1	Air Filter (Pro DRY S)	21-90105
A2	1	Air Filter (Pro 5R)	23-91133
B	1	Tube	05-5310017B1
C	1	Housing	05-5310017B2
D	1	Coupling, Silicone Bellow: 3"L	05-01480
E	1	Coupling, Silicone Bellow	05-01457
F	2	Clamp, #048	03-50007
G	1	Clamp, #072	03-50010
H	1	Clamp, #080	03-50011
I	1	CCV Fitting, Large	05-01339
J	1	Grommet, Rubber	03-50167
K	1	Fitting, Air Temp Sensor	05-01454

Installation will require the following tool(s):

8mm nut driver or flat-head screwdriver, 10mm socket and driver, #3 Phillips-head screwdriver, panel popper tool, 20mm wrench or adjustable wrench, and needle nose pliers.

Warranty Information available at: <https://afepower.com/contact#warranty>

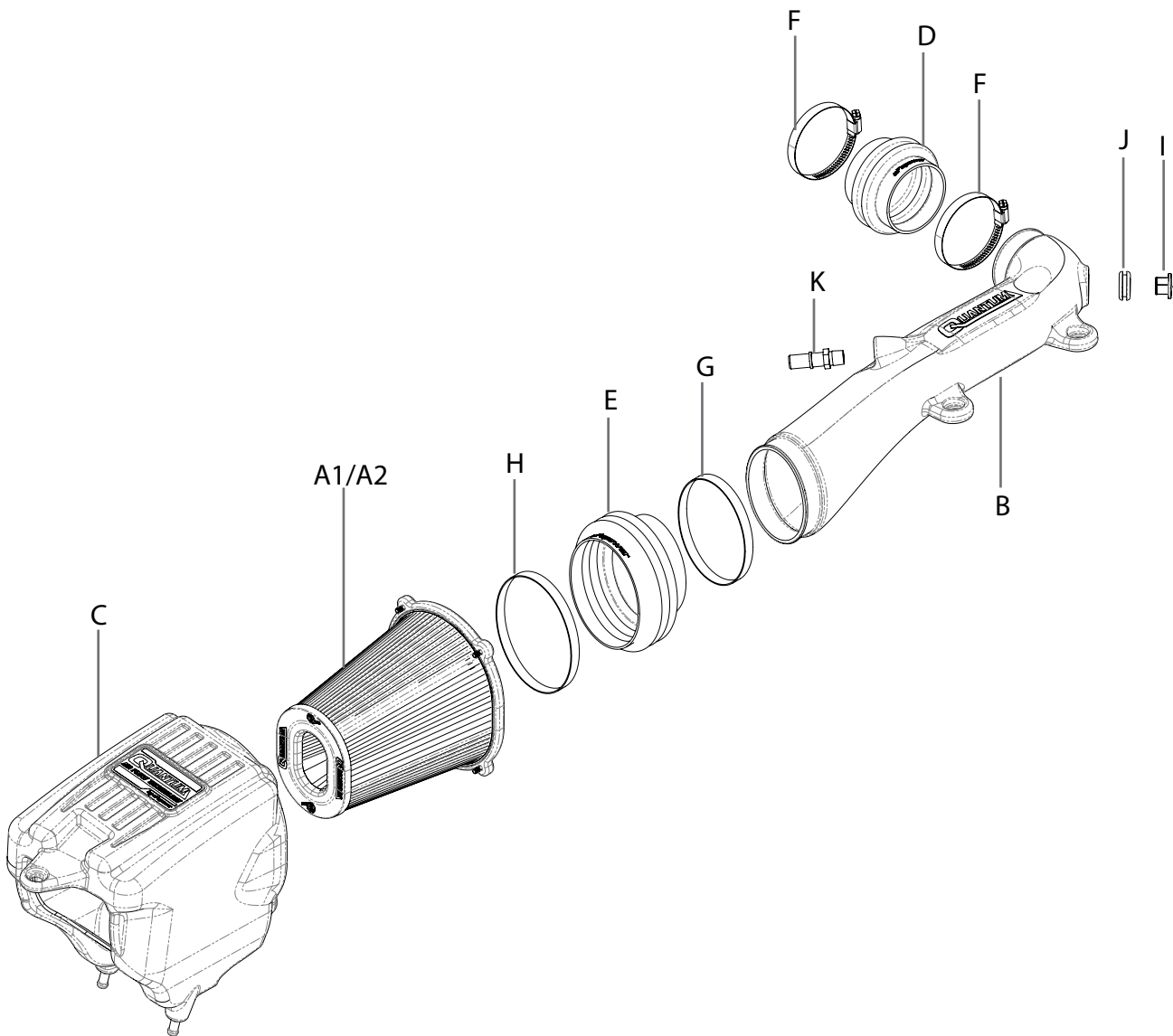

**FigureA**

Refer to Figure A for Steps 1-2

Step 1: Using a 10mm socket and driver, remove the (3) screws ① securing the factory intake to the vehicle.

Step 2: Using an 8mm nut driver, loosen the two clamps ② on the intake tube.



Figure B

Refer to Figure B for Steps 3-5

Step 3: Disconnect the Crank Case Vent (CCV) ③ by pushing on the grey clip and sliding the tube off the fitting.

Step 4: Disconnect the Intake Air Temperature (IAT) sensor ④.

Step 5: Remove the two (2) attaching clips for the IAT sensor harness ⑤ and the one (1) clip ⑥ holding the coolant line from the right side of the intake tube.



Refer to Figure C for Steps 6-8

Step 6: Remove the factory intake tube from the vehicle.

Step 7: Remove the factory housing from the vehicle by lifting straight upward. If the rubber grommets pop off with the housing, then remove them from the housing and place them back into the holes in the mounting bracket.

Step 8: If the attaching clips on the IAT sensor harness and the coolant line are bent out of shape, then repair them so that they look like the clip shown.



Figure D

Refer to Figure D for Steps 9-10

Step 9: Remove the metal sleeves and rubber grommets (7) from the factory intake tube and reinstall them into the aFe POWER intake tube.

Step 10: Using a 20mm wrench or adjustable wrench, install the supplied aluminum vent fitting (8) into the aFe POWER intake tube.



Refer to Figure E for Steps 11-13

- Step 11: Install the grommet and temp sensor adaptor (9) into the hole on the front of the intake tube. Make sure that the bead on the adaptor is positioned correctly in the grommet so that it cannot pop out during use.
- Step 12: Carefully remove the IAT sensor (10) from the factory intake tube by lifting it up slightly on the plastic tab and rotating the sensor 1/4 turn counterclockwise.
- Step 13: Reinstall the IAT sensor into the temp sensor adaptor on the aFe POWER intake tube and make sure to lock it into position by rotating it clockwise until the small tab clicks into place.



Figure F

Refer to Figure F for Step 14

Step 14: Remove the metal sleeve and rubber grommet ⑪ from the factory housing and reinstall them into the aFe POWER housing as shown.



Figure G

Refer to Figure G for Steps 15-16

Step 15: Slide the aFe POWER filter into the aFe POWER housing. Install the filter using a #3 Phillips screwdriver. Tighten all four (4) screws.

Step 16: Install the aFe POWER housing and filter assembly into the vehicle by lining up the pegs into the grommets and then pressing down firmly to lock them into place. Use one of the screws removed in Step 1 to secure the housing to the fender.



Figure H

Refer to Figure H for Steps 17-18

Step 17: Install the supplied large bellows coupler (12) onto the air filter using the supplied #80 clamp (13).
Tighten this clamp.

Step 18: Place the #72 clamp (14) onto the filter coupler. Do NOT tighten this clamp.



Figure I

Refer to Figure I for Step 19

Step 19: Place the two #48 clamps (15) loosely over each end of the smaller coupler (16) and then install the coupler and clamps onto the end of the intake tube.



Figure J

Refer to Figure J for Steps 20-22

Step 20: Insert the large end of the tube into the filter coupler and then rotate the other end of the tube so that the coupler slides onto the throttle body.

Step 21: Connect the CCV to the aluminum fitting (17) on the intake tube and plug in the IAT sensor (18).

Step 22: Using the remaining two (2) screws (19) removed in Step 1, secure the intake tube to the core support.



Figure K

Refer to Figure K for Steps 24-26

Step 24: Tighten all four (4) clamps using an 8mm nut driver or a flat-head screwdriver. Do not over tighten the clamps.

Step 25: Verify that all connectors are secure and the three (3) screws are tightened properly.

Step 26: Your installation is now complete. Thank you for choosing aFe POWER.

NOTE: Retighten all connections after approximately 100-200 miles.

Please enclosed CARB EO sticker on or near the device on a smooth, clean surface.

EO identification label is required to pass the smog inspection.

Page left blank intentionally



advanced FLOW engineering, inc.
252 Granite Street Corona, CA 92879
<https://afepower.com/contact>