

advanced FLOW engineering Quantum Cold Air Intake System

Instruction Manual P/N: 53-10023D / 53-10023R

Make: Ford Model: Transit 150/250/350/350HD Year: 2016-2020 Engine: V6-3.5L (tt)
(W/Air Temp Sensor only)



- Please read the entire instruction manual before proceeding.
- Ensure all components listed are present.
- For technical support please call 951-493-7185.
- Ensure you have all necessary tools before proceeding.
- Do not attempt to work on your vehicle when the engine is hot.
- Retain factory parts for future use.

Label	Qty.	Description	Part Number
A1	1	Air Filter (Pro 5R)	23-91132
A2	1	Air Filter (Pro DRY S)	21-90103
B	1	Tube	05-5310023B1
C	1	Housing	05-5310023B2
D	1	Brass Fitting: 5/16 ID x 1/8 NPT	03-50192
E	1	Clamp, 080 (3-1/2" – 5-1/2")	03-50011
F	1	Clamp, 072 (3" - 5")	03-50010
G	1	Coupling, Silicone Bellow	05-01457
H	1	Coupling, Silicone Hump	05-01264
I	2	Clamp, 060 (3-5/16" - 4-1/4")	03-50002
J	1	Grommet, Rubber	03-50167
K	1	Fitting, Air Temp Sensor	05-01454

Installation will require the following tools:

7mm & 8mm nut driver, T-25 driver, Phillips #2 & #3 screwdriver, 1/2" open wrench, 10mm deep socket, 15mm socket & ratchet

Emissions Disclaimer: This product is not currently CARB exempt and is not available for purchase in California or for use on any vehicle registered with the California Department of Motor Vehicles.

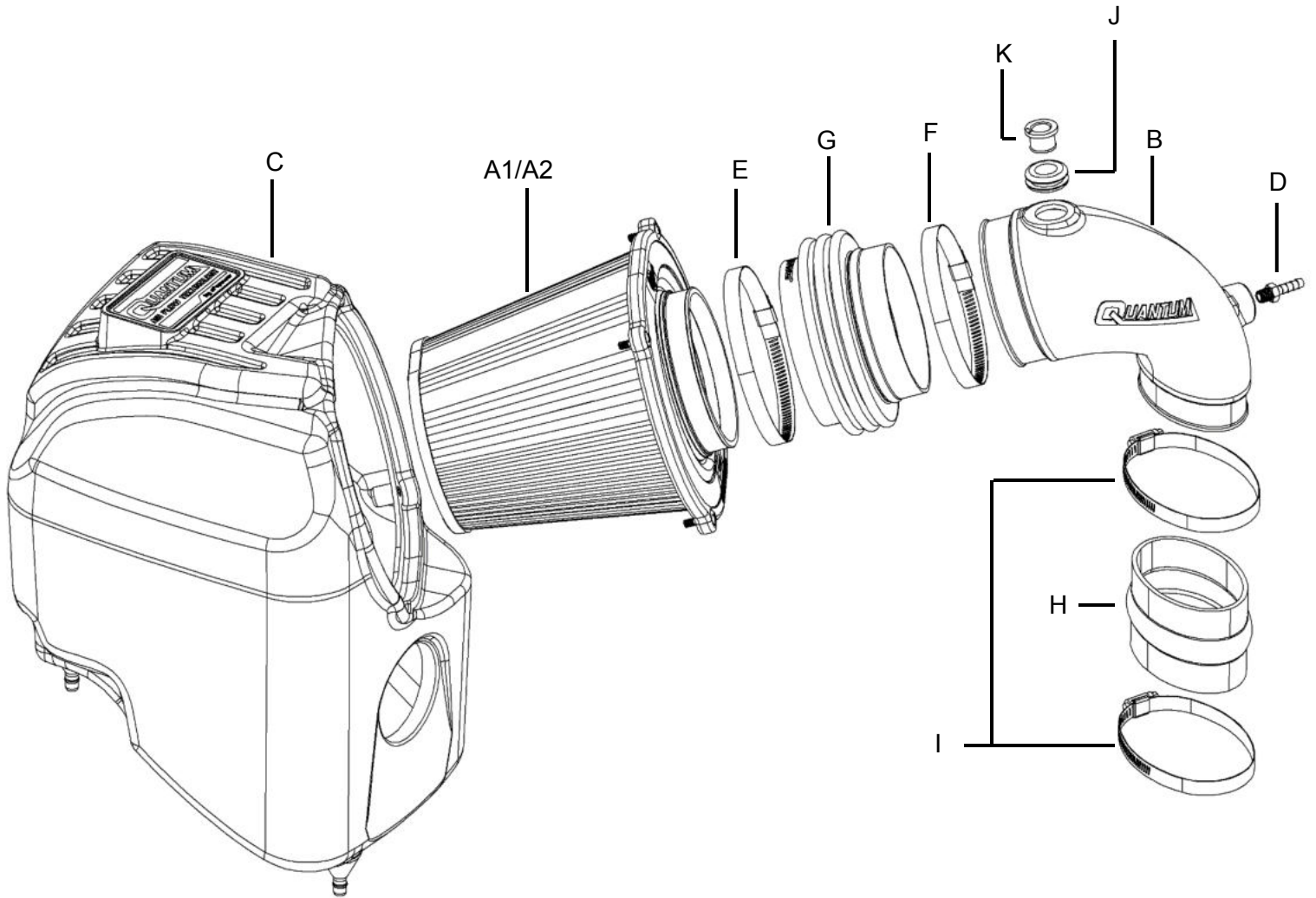

**Figure A****Refer to Figure A for Step 1**

Step 1: Using a 10mm deep socket and ratchet, remove the 3 nuts located at the firewall (1) behind the factory filter housing supporting the air inlet for the HVAC.



Figure B

Refer to Figure B for Steps 2-3

Step 2: Using a #2 Phillips screwdriver, remove the 2 screw clips (2) located at the corner of the cowl panel, then remove the plastic corner piece (3).

Step 3: Remove the screw clip (4) that you'll see under the plastic corner piece.



Figure C

Refer to Figure C for Steps 4-6

Step 4: Using a 15mm socket and ratchet, remove the nut (5) on the passenger side windshield wiper arm (6) and remove the wiper arm.

Step 5: Remove the screw clip located on the top right corner of the air inlet.

Step 6: Pull up on the cowl panel to access the two torx screws (7) holding up the air inlet, remove the two screws using a T-25 driver.

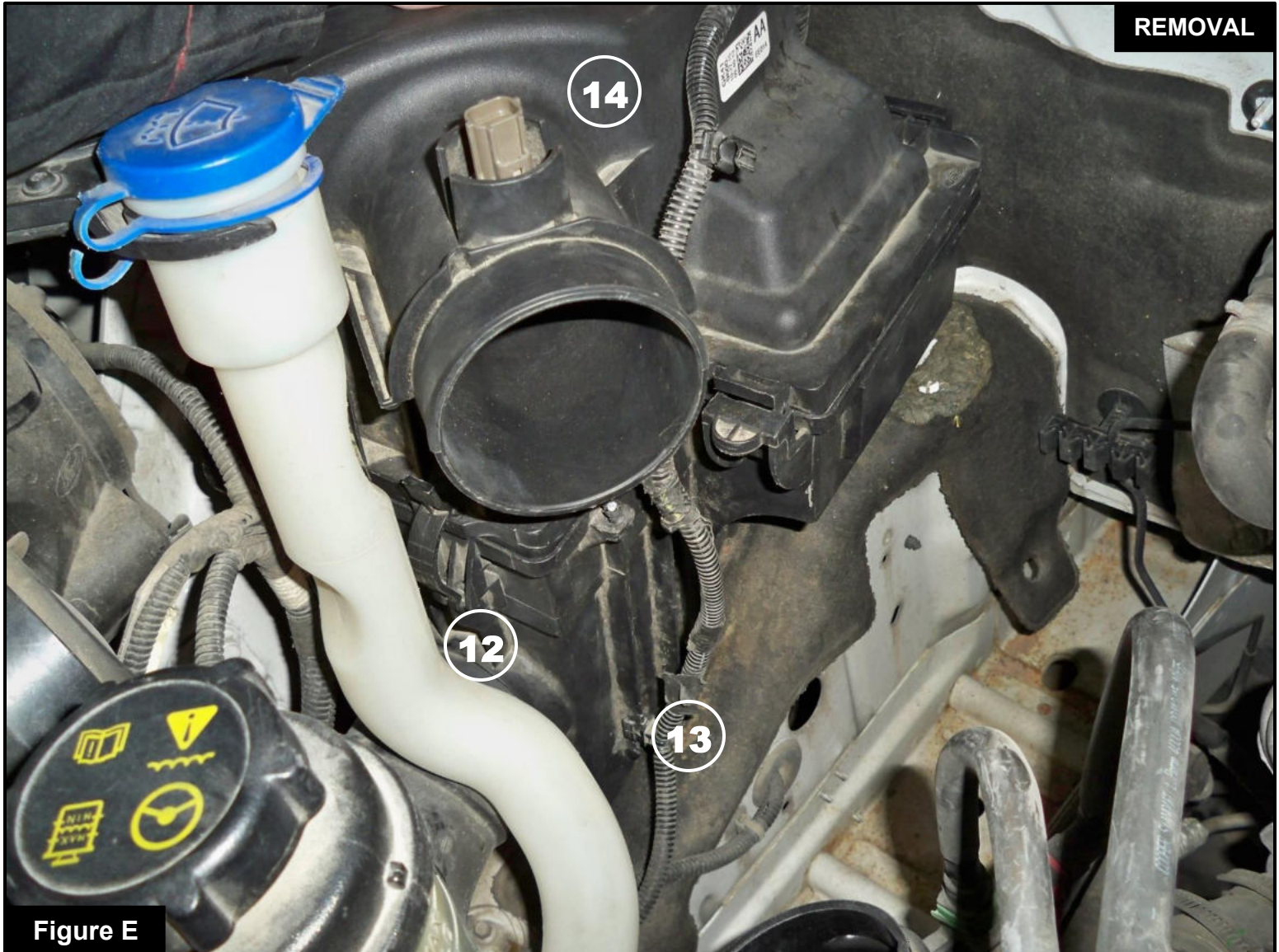

Figure D

Refer to Figure D for Steps 7-9

Step 7: Disconnect the air temperature sensor connector (8).

Step 8: Using a 7mm nut driver, loosen the clamps (9) at both ends of the intake duct (10).

Step 9: Disconnect the vacuum hose (11) from the intake duct and remove the intake duct from the vehicle.

Figure E

Refer to Figure E for Steps 10-13

Step 10: Detach the air scoop (12) from the front of the filter housing.

Step 11: Detach the wiring harness retainers from the filter housing (13).

Step 12: Unclip the filter housing cover (14). Remove the cover and the air filter.

Step 13: Lift the housing off the mounting grommets and remove it.

Figure F

Refer to Figure F for Steps 14-17

- Step 14: Remove the air temperature sensor (15) from the filter housing cover by rotating it quarter turn counter-clockwise and gently pulling outward.
- Step 15: Install the provided rubber grommet (16) and sensor fitting (17) into the aFe intake tube.
- Step 16: Install the air temperature sensor into the aFe intake tube by inserting it into the sensor fitting and rotating it quarter turn clockwise until it locks into place.
- Step 17: Using a ½" open wrench, install the supplied brass fitting (18) into the aFe intake tube.

**Figure G****Refer to Figure G for Steps 18-19**

Step 18: Install the aFe housing into the vehicle, make sure the mounting pins from the aFe housing are fully seated into the mounting grommets.

Step 19: Feed the air scoop into the aFe housing front opening making sure it secures into place.



Figure H

Refer to Figure H for Step 20

Step 20: Slide the aFe filter into the aFe housing. Install the aFe filter using a #3 Phillips screwdriver.

Tighten all (x4) screws.

Figure I

Refer to Figure I for Steps 21-22

Step 21: Install the supplied bellows coupling (19) onto the round side of the intake tube using the supplied #72 clamp (20). Place the supplied #80 clamp (21) on the larger side of the bellows coupling.

Step 22: Install the supplied hump coupling (22) on the oval side of the intake tube with both supplied #60 clamps (23) onto the coupling. Do not tighten the clamps at this point.

**Figure J****Refer to Figure J for Steps 23-26**

Step 23: Install the aFe intake tube into the vehicle. Slide the hump coupling onto the air inlet duct first and then install the bellows coupling to the filter.

Step 24: Align the aFe intake tube correctly then using an 8mm driver tighten all the clamps.

Step 25: Connect the vacuum hose (24) to the brass fitting.

Step 26: Reconnect the air temperature sensor (25).



Figure K

Refer to Figure K for Steps 27-28

Step 27: Reverse steps 1-6 to put the cowl panel back on.

Step 28: Check all the components are tight and secure. Your installation is now complete. Thank you for choosing aFe POWER!

NOTE: Check all screws, clamps, and connectors are secure after 100-200 miles.



Page left blank intentionally



Page left blank intentionally



Page left blank intentionally



Pro DRY S Air Filter Inv.



P/N: 21-91132

Pro 5R Air Filter Inv.



P/N: 23-91132

Pro-GUARD 7 Air Filter Inv.



P/N: 72-91132

Pro DRY S Air Filter



P/N: 21-90103

Pro DRY S Restore Kit



P/N: 90-59999

Blue Squeeze Restore Kit



P/N: 90-50501

Gold Squeeze Restore Kit



P/N: 90-50500

Pre-Filter



P/N: 28-10423

Flashlight LED



P/N: 40-10202

Sprint Booster



P/N: 77-13001

Apollo GT Series Exhaust



P/N: 49-43113

Vulcan Series Exhaust



P/N: 49-33112-B

To purchase any of the items above, view airflow charts, dyno graphs, photos, and video; please go to aFepower.com.



Warranty

General Terms:

- aFe warrants their products to be free from manufacturer's defects due to workmanship and material.
- This warranty applies only to the original purchaser of the product and is non-transferrable.
- Proof of purchase of the aFe product is required for all warranty claims.
- Warranty is valid provided aFe instructions for installation and/or cleaning were properly followed.
- Proper maintenance with regular inspections of product is required to insure warranty coverage.
- Damage due to improper installation, abuse, unauthorized repair or alteration is not warranted.
- Incidental or consequential damages or cost, including installation and removal of part, incurred due to failure of aFe product is not covered under this warranty.
- All warranty is limited to the repair and/or replacement of the aFe part. To request Return Goods Authorization ("RGA"), email RGA@afepower.com or call (951)493-7100. Upon receipt of the RGA, you must return the product to the address provided in the RGA, freight prepaid and accompanied with a dated proof of purchase and the RGA. Upon receipt of the defective product and upon verification of proof of purchase, aFe will either repair or replace the defective product within a reasonable time, not to exceed thirty days.

Product Category	P/N Prefix	Warranty duration
Direct OE Replacement Filters	10, 11, 30, 31, 71, 73	Life of the vehicle
Racing Filters	18	1 year
Universal	20, 21, 23, 24, 72, TF	2 years
Air Intake Systems	50, 51, 53, 54, 55, 56, 57, 58, 75, TR, TA, TL, TM	2 years
Exhaust Systems	49	2 years
Intercoolers & Intercooler Tubes	46-2	2 years
Intake Manifolds	46-1	2 years
Differential Cover	46-7	Life of the vehicle
Exhaust Manifolds	46	2 years
Throttle Body Spacers	46-3	2 years
Turbochargers	46-6	2 years*
Fluid Filters	44	90 days
Pre-Filters	28	2 years
Heavy Duty OE Replacement	70	2 years
PowerSports OE Replacement	81, 87	2 years
PowerSports Intake Systems	85	2 years

No other warranty expressed or implied applies nor is any person or advanced FLOW engineering authorized to assume any other warranty. Some States do not allow the exclusion or limitation of incidental or consequential damages or do not allow limitations on how long an implied warranty lasts, so the above limitations or exclusions may not apply to you. This warranty gives you specific legal rights, and you may also have other rights which vary from State to State.

*See turbocharger warranty for more info



advanced FLOW engineering, inc.

252 Granite Street Corona, CA 92879

TECH: 951.493.7185

E-Mail: Tech@aFepower.com

P/N: 06-81312