

advanced FLOW engineering Quantum Cold Air Intake System

Instruction Manual P/N: 53-10029D / 53-10029R

Make: Chevrolet Model: Silverado 1500 Year: 2009-2013 Engine: V8-4.8L/5.3L/6.2L
Make: GMC Model: Sierra 1500 Year: 2009-2013 Engine: V8-4.8L/5.3L/6.2L



- Please read the entire instruction manual before proceeding.
- Ensure all components listed are present.
- If you are missing any of the components, call customer support at 951-493-7100.
- Ensure you have all necessary tools before proceeding.
- Do not attempt to work on your vehicle when the engine is hot.
- Disconnect the negative battery terminal before proceeding.
- Retain factory parts for future use.

Label	Qty.	Description	Part Number
A1	1	Air Filter (Pro 5R)	23-91129
A2	1	Air Filter (Pro DRY S)	21-90098
B	1	Tube	05-5310029B1
C	1	Housing	05-54006B2
D	1	Seal, Trim: 7/16" Bulb (26"L)	05-00072
E	1	Clamp, 080 (3-1/2" – 5-1/2")	03-50011
F	1	Clamp, 072 (3" - 5")	03-50010
G	1	Coupling, Silicone Bellow	05-01457
H	1	Coupling, Silicone Reducer	05-01459
I	1	Clamp, 060 (3-5/16" - 4-1/4")	03-50002
J	1	Clamp, 064 (2-1/2" – 4-1/2")	03-50006
K	2	Screw, Torx: M4 x .7 x 8mm	03-50491
L	1	Hose, Silicone Breather, Black (14"L)	05-01396
M	1	Clamp, Mini 006 (7/16" - 25/32")	03-50025

Installation will require the following tools:

8mm nut driver, T15 & T20 Torx drivers, Phillips #3 screwdriver, small flat-head screwdriver.

Emissions Disclaimer: This product is not currently CARB exempt and is not available for purchase in California or for use on any vehicle registered with the California Department of Motor Vehicles.

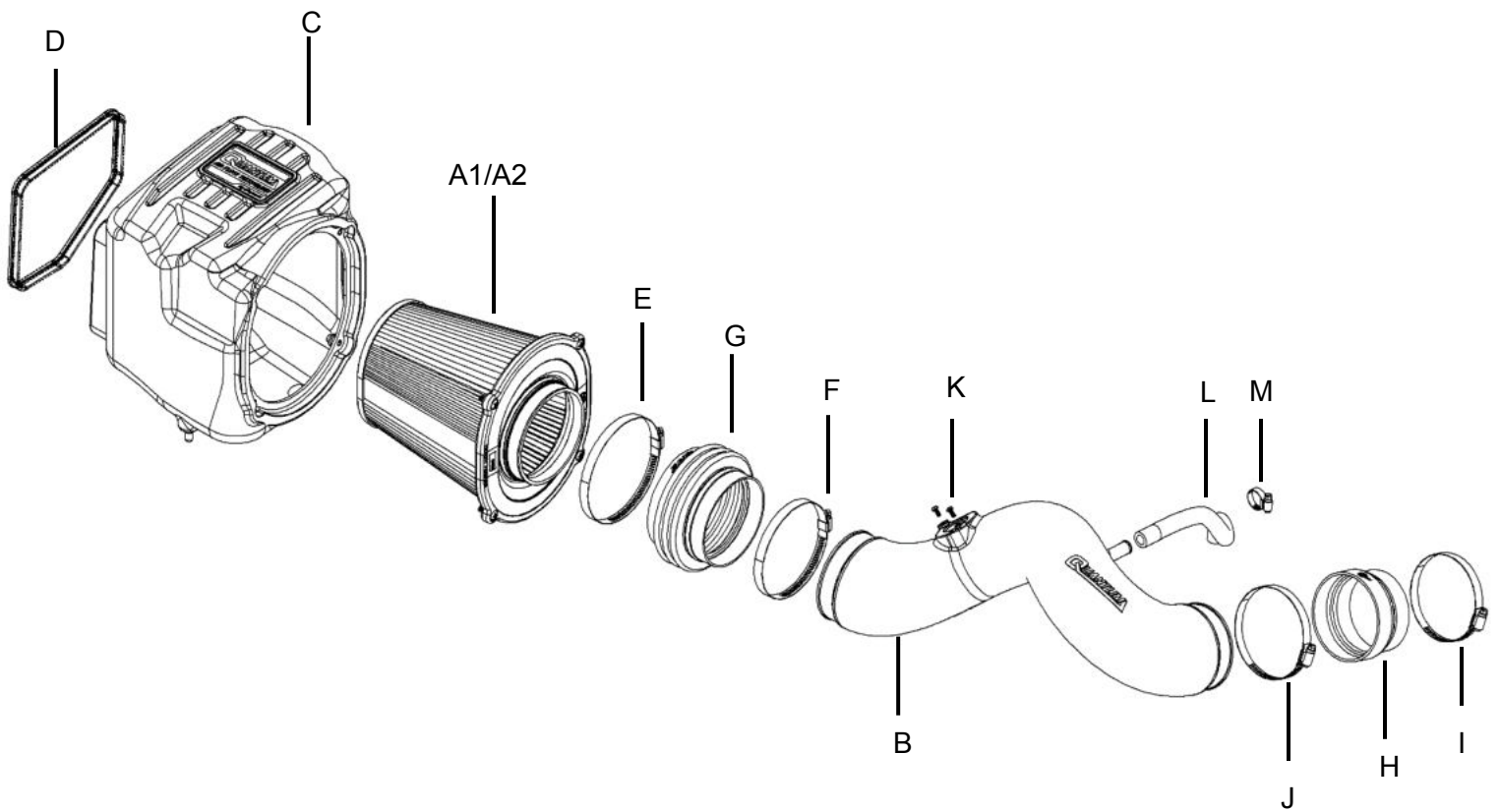

**Figure A****Refer to Figure A for Steps 1-3**

Step 1: Remove the engine cover ① and set aside.

Step 2: Disconnect the MAF sensor ②.

Step 3: Using an 8mm nut driver, loosen the hose clamps at the housing ③ and the throttle body ④.



Figure B

Refer to Figure B for Step 4

Step 4: Disconnect the radiator hose clip from the OE intake tube.



Figure C

Refer to Figure C for Steps 5-6

Step 5: Disconnect the OE crankcase breather hose from the resonator chamber (as shown) and remove it from the valve cover fitting.

Step 6: Carefully remove the entire intake tube out of the vehicle.



Figure D

Refer to Figure D for Step 7

Step 7: Remove the factory housing ⑤ out of the vehicle.

**Figure E****Refer to Figure E for Steps 8-9**

Step 8: Slide the aFe filter into the aFe housing. Install the aFe filter using a #3 Phillips screwdriver. Tighten all (x4) screws.

Step 9: Install the supplied bellows coupling (6) onto the air filter using the supplied #80 clamp (7). Tighten the clamp.

**Figure F****Refer to Figure F for Steps 10-11**

Step 10: Install the trim seal (8) on the opening of the aFe housing.

Step 11: Remove the retaining plug (9) from the bottom of the factory housing and transfer it to the aFe housing.



Refer to Figure G for Step 12

Step 12: Install the aFe housing assembly into the vehicle. Firmly push the housing into the factory mounting grommets.

**Figure H****Refer to Figure H for Steps 13-14**

Step 13: Remove the MAF sensor (10) from the factory housing using a T15 Torx driver.

Step 14: Using a T20 torx driver, install the MAF sensor into the aFe intake tube using the supplied M4 screws.

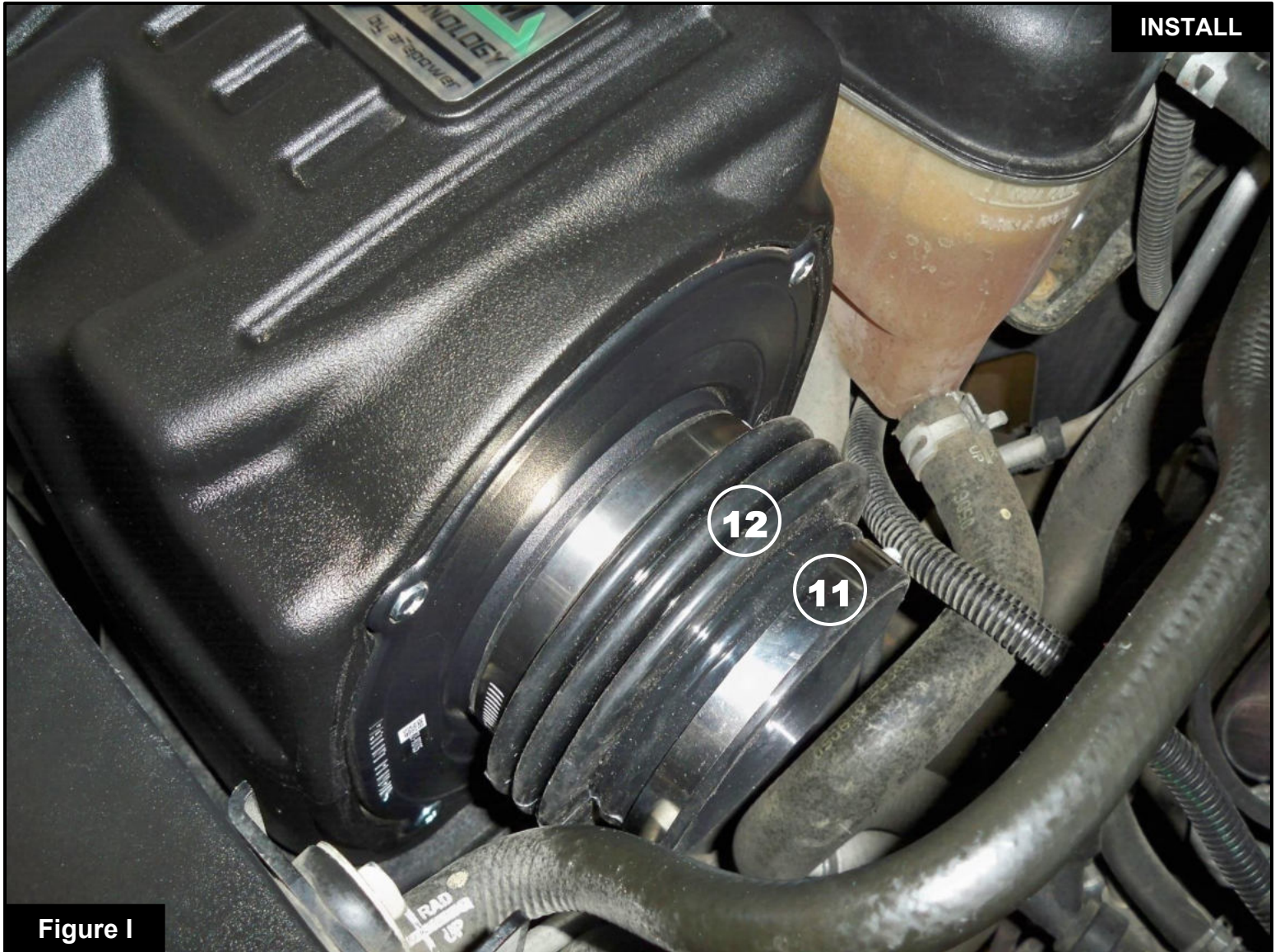
**Figure I****Refer to Figure I for Step 15**

Step 15: Place the #72 clamp (11) onto the filter coupling (12). Do NOT tighten the clamp.

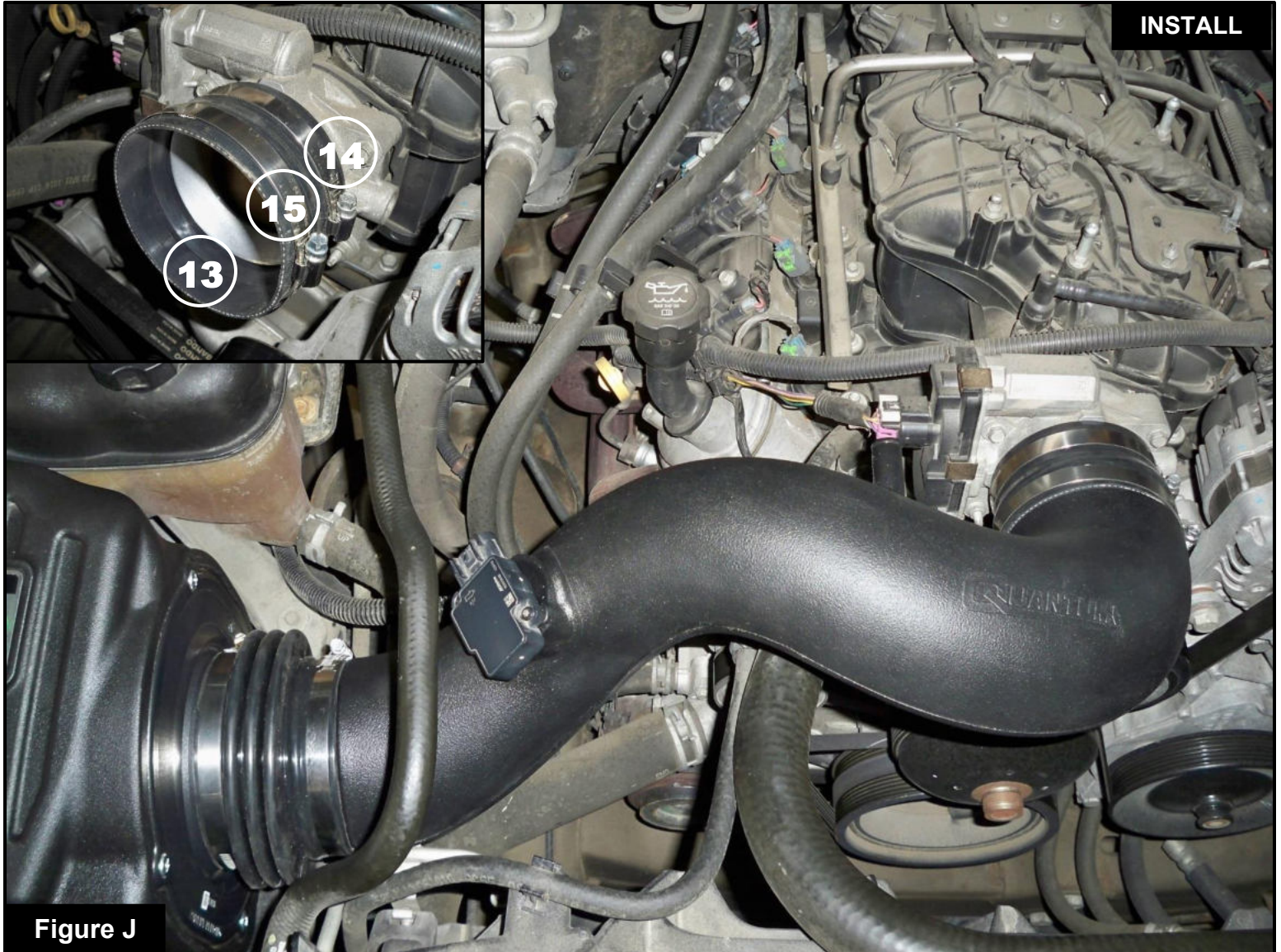

Figure J

Refer to Figure J for Steps 16-18

Step 16: Install the supplied reducer coupling (13) with the smaller diameter on the throttle body and the #60 clamp (14). Place the #64 clamp (15) on the other end of the coupling. Do not tighten the clamps at this time.

Step 17: Install the aFe intake tube into the vehicle. Slide the aFe intake tube into the filter coupling and then into the coupling on the throttle body.

Step 18: Align the aFe intake tube correctly then tighten all the clamps.

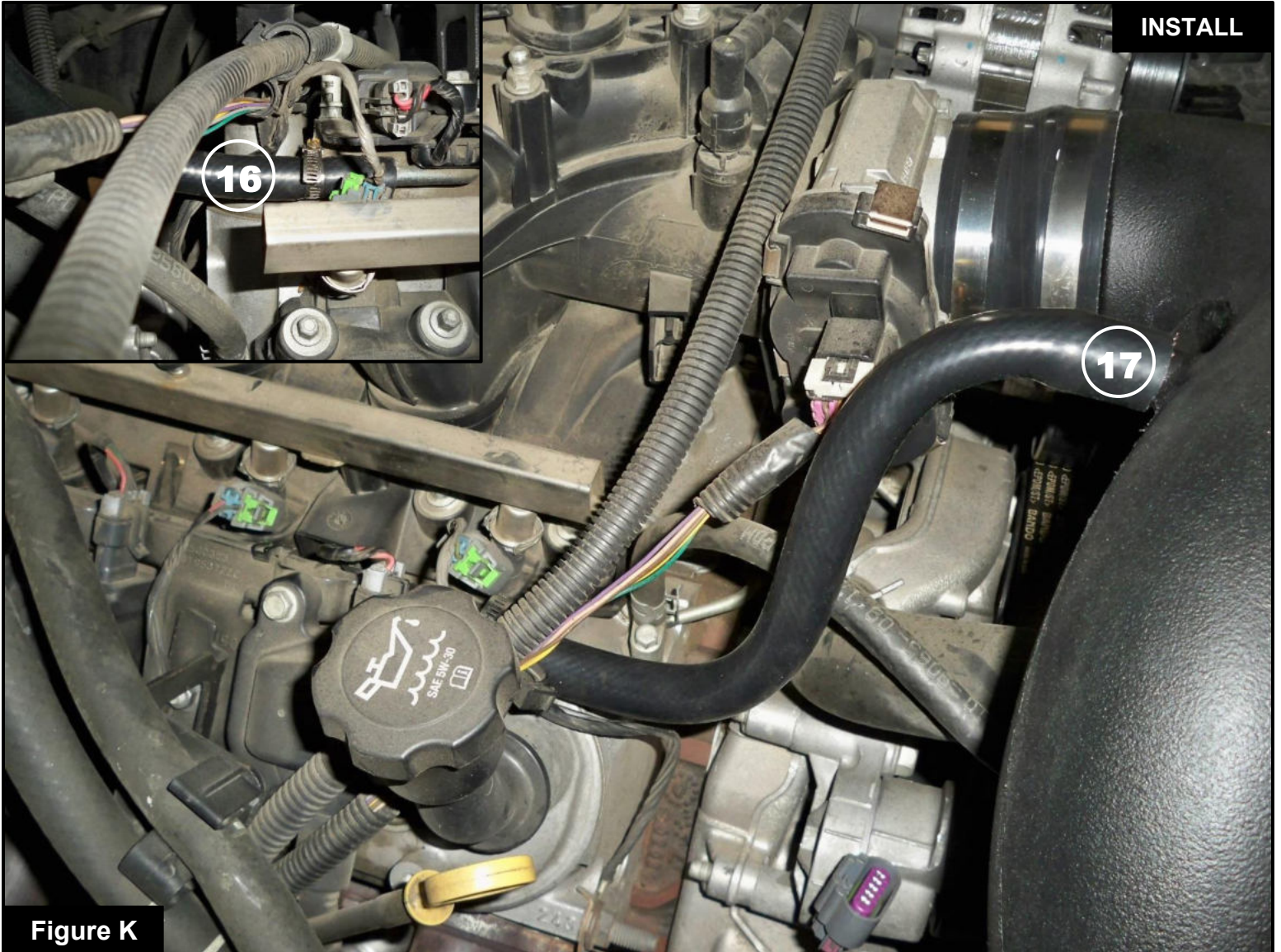

Refer to Figure K for Steps 19-20

Step 19: Using the supplied mini clamp, install one end of the supplied silicone breather hose (16) on the tube coming out of the valve cover where the stock vent hose was removed. (Make sure the hose goes over the bead on the tube). Tighten the mini clamp.

Step 20: Install the other end of the silicone breather hose (17) on the aFe intake tube.

**Figure L****Refer to Figure L for Steps 21-23**

Step 21: Reconnect the MAF sensor (18).

Step 22: Reinstall the engine cover (19).

Step 23: Check all the components are tight and secure. Your installation is now complete. Thank you for choosing aFe POWER!

NOTE: Check all screws, clamps, and connectors are secure after 100-200 miles.



Page left blank intentionally



Page left blank intentionally



Pro DRY S Air Filter Inv.



P/N: 21-91129

Pro 5R Air Filter Inv.



P/N: 23-91129

Pro-GUARD 7 Air Filter Inv.



P/N: 72-91129

Pro DRY S Air Filter



P/N: 21-90098

Pro DRY S Restore Kit



P/N: 90-59999

Blue Squeeze Restore Kit



P/N: 90-50501

Gold Squeeze Restore Kit



P/N: 90-50500

Pre-Filter



P/N: 28-10423

SCORCHER PRO Tune



P/N: 77-34003

SCORCHER PRO Tune



P/N: 77-34008

Sprint Booster



P/N: 77-14003

Silver Bullet TBS



P/N: 46-34003

To purchase any of the items above, view airflow charts, dyno graphs, photos, and video; please go to aFepower.com.



Warranty

General Terms:

- aFe warrants their products to be free from manufacturer's defects due to workmanship and material.
- This warranty applies only to the original purchaser of the product and is non-transferrable.
- Proof of purchase of the aFe product is required for all warranty claims.
- Warranty is valid provided aFe instructions for installation and/or cleaning were properly followed.
- Proper maintenance with regular inspections of product is required to insure warranty coverage.
- Damage due to improper installation, abuse, unauthorized repair or alteration is not warranted.
- Incidental or consequential damages or cost, including installation and removal of part, incurred due to failure of aFe product is not covered under this warranty.
- All warranty is limited to the repair and/or replacement of the aFe part. To request Return Goods Authorization ("RGA"), email RGA@afepower.com or call (951)493-7100. Upon receipt of the RGA, you must return the product to the address provided in the RGA, freight prepaid and accompanied with a dated proof of purchase and the RGA. Upon receipt of the defective product and upon verification of proof of purchase, aFe will either repair or replace the defective product within a reasonable time, not to exceed thirty days.

Product Category	P/N Prefix	Warranty duration
Direct OE Replacement Filters	10, 11, 30, 31, 71, 73	Life of the vehicle
Racing Filters	18	1 year
Universal	20, 21, 23, 24, 72, TF	2 years
Air Intake Systems	50, 51, 53, 54, 55, 56, 57, 58, 75, TR, TA, TL, TM	2 years
Exhaust Systems	49	2 years
Intercoolers & Intercooler Tubes	46-2	2 years
Intake Manifolds	46-1	2 years
Differential Cover	46-7	Life of the vehicle
Exhaust Manifolds	46	2 years
Throttle Body Spacers	46-3	2 years
Turbochargers	46-6	2 years*
Fluid Filters	44	90 days
Pre-Filters	28	2 years
Heavy Duty OE Replacement	70	2 years
PowerSports OE Replacement	81, 87	2 years
PowerSports Intake Systems	85	2 years

No other warranty expressed or implied applies nor is any person or advanced FLOW engineering authorized to assume any other warranty. Some States do not allow the exclusion or limitation of incidental or consequential damages or do not allow limitations on how long an implied warranty lasts, so the above limitations or exclusions may not apply to you. This warranty gives you specific legal rights, and you may also have other rights which vary from State to State.

*See turbocharger warranty for more info



advanced FLOW engineering, inc.

252 Granite Street Corona, CA 92879
TEL: 951.493.7100 • TECH: 951.493.7134
E-Mail: Tech@aFepower.com

P/N: 06-81271