

**advanced FLOW engineering** Cold Air Intake System

**Instruction Manual** P/N: 53-10026D / 53-10026R

Make: Dodge/RAM Model: 2500/3500 Year: 2007.5-2009 Engine: L6-6.7L (td) Cummins



- Please read the entire instruction manual before proceeding.
- Ensure all components listed are present.
- If you are missing any of the components, call customer support at 951-493-7134.
- Ensure you have all necessary tools before proceeding.
- Do not attempt to work on your vehicle when the engine is hot.
- Retain factory parts for future use.

Label	Qty.	Description	Part Number
A1	1	Air Filter (Pro 5R)	23-91129
A2	1	Air Filter (Pro DRY S)	21-90098
B	1	Tube	05-5310015B1
C	1	Housing	05-5310032B2
D	2	Screw, Torx: M4 x .7 x 10mm	03-50490
E	1	Screw, Torx: M4 x .7 x 16mm	03-50489
F	1	Clamp, 080 (3-1/2" – 5-1/2")	03-50011
G	2	Clamp, 072 (3" - 5")	03-50010
H	1	Coupling, Silicone Bellow	05-01457
I	1	Coupling, Silicone Elbow w/port	05-01464
J	1	Clamp, 064 (2-1/2"- 4-1/2 ")	03-50006
K	1	Clamp, Mini 012 (11/16" - 1-1/4")	03-50023
L	1	Hose, Silicone Breather: 3/4" ID, Black (6"L)	05-01475

**Installation will require the following tools:**

8mm nut drivers, T20 Torx driver, 10mm socket & ratchet, Phillips #3 and flat blade screwdrivers, pliers

Warranty Information available at <https://afepower.com/contact#warranty>

**Emissions Disclaimer:** This product is not currently CARB exempt and is not available for purchase in California or for use on any vehicle registered with the California Department of Motor Vehicles.

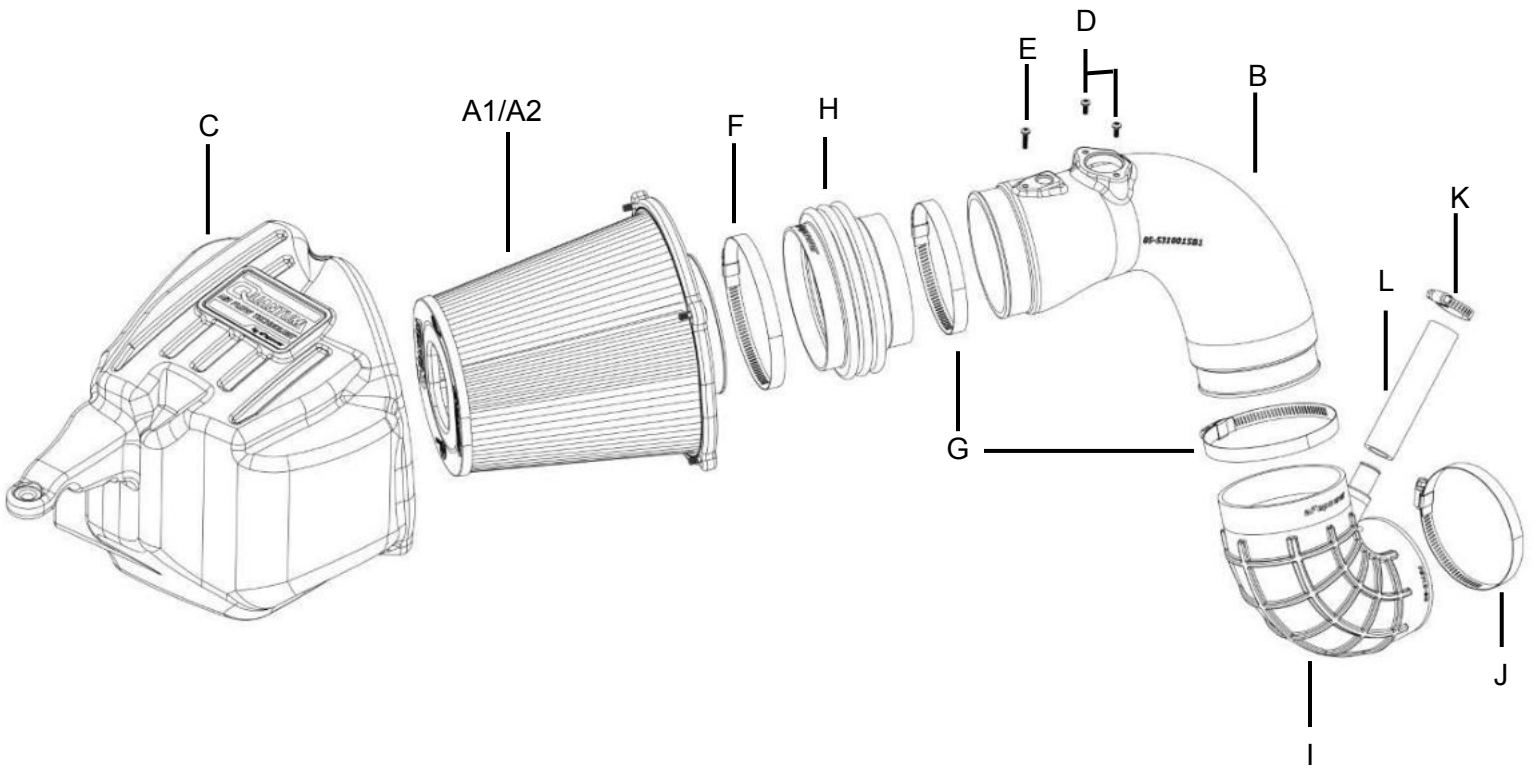

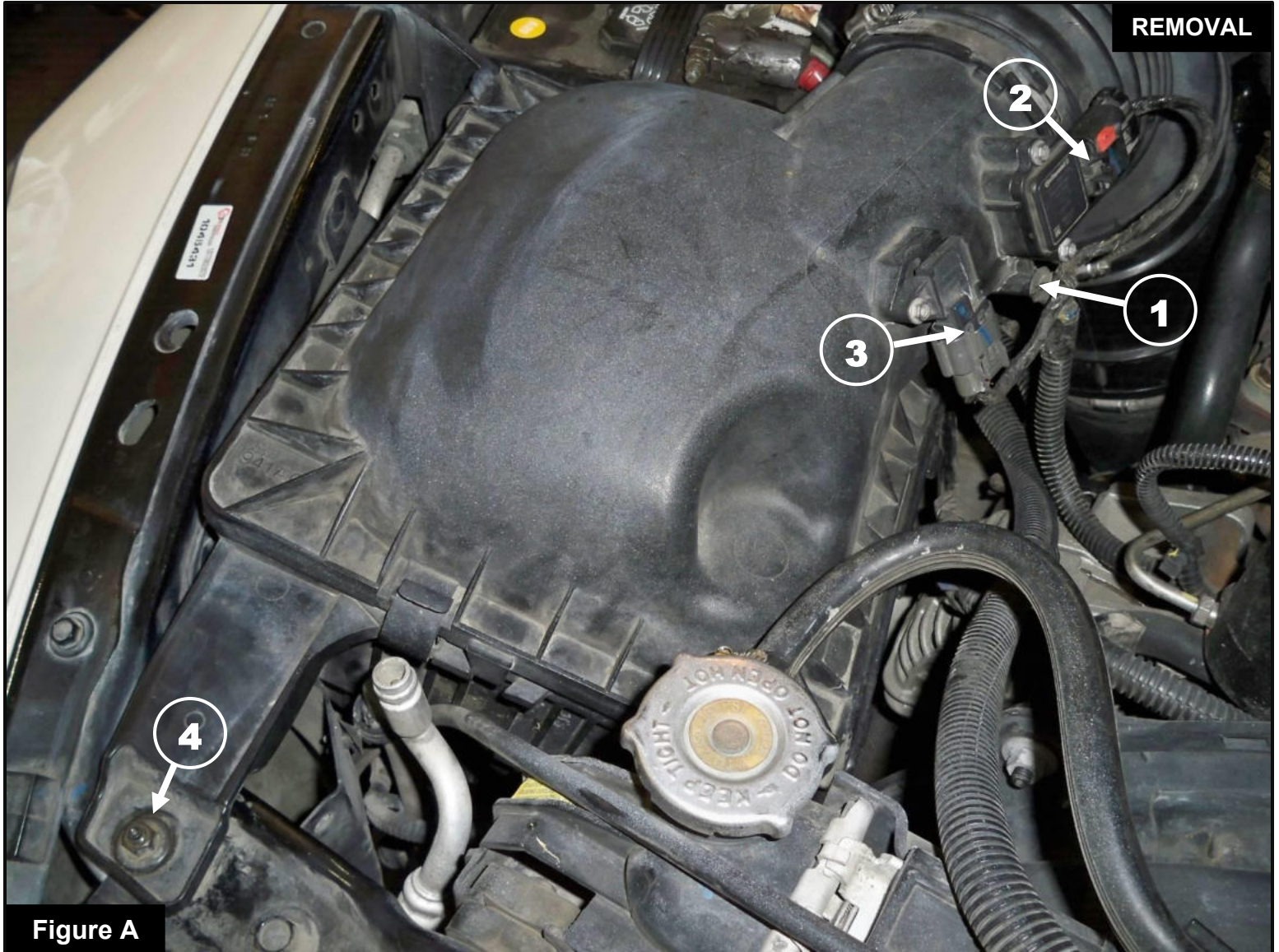
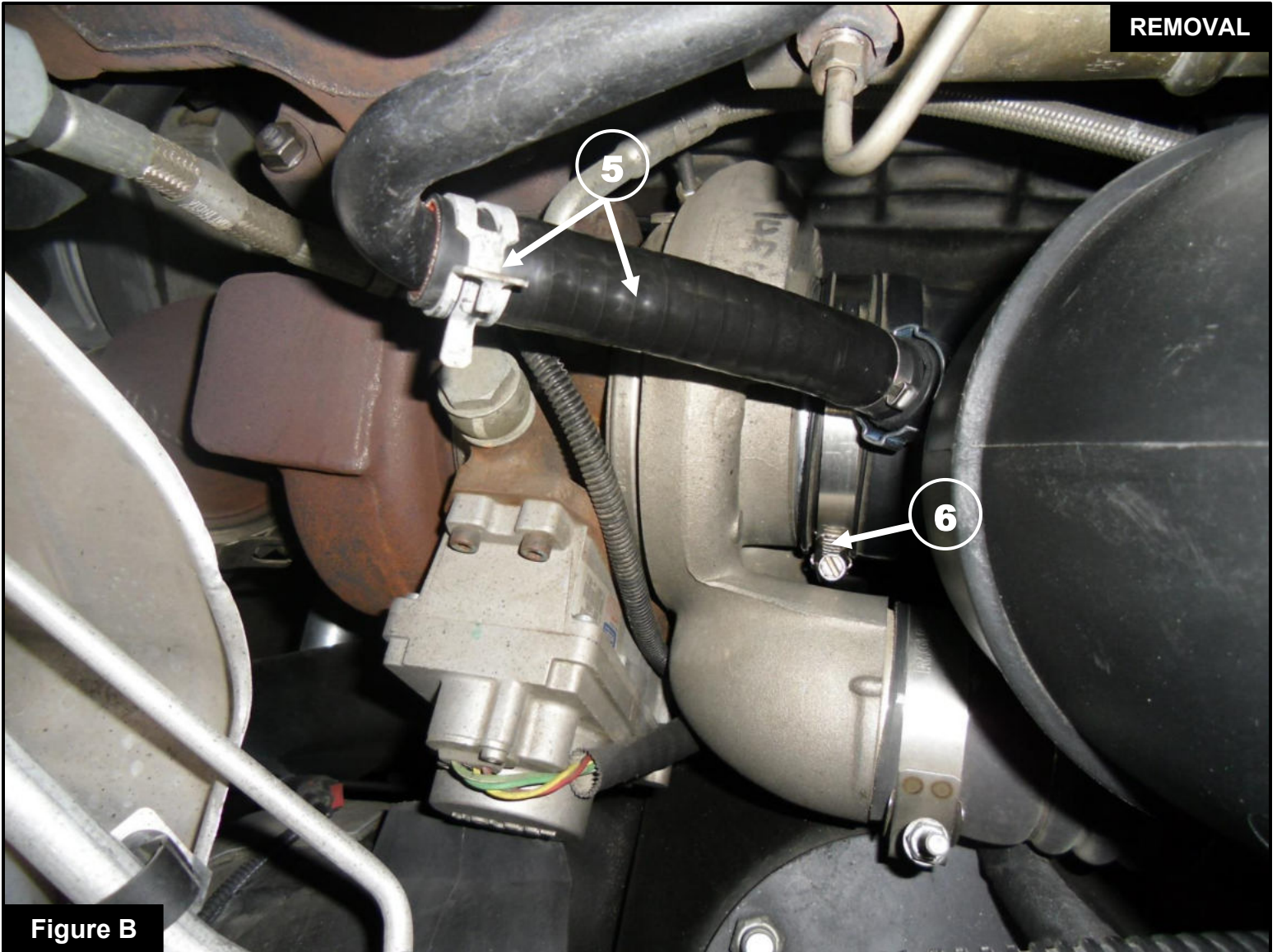

Figure A

**Refer to Figure A for Steps 1-2**

Step 1: Disconnect the wiring harness retaining clip (1), the MAF sensor (2) and the TBAP sensor (3).

Step 2: Using a 10mm socket and ratchet, remove the nut (4) holding down the factory housing.

**Figure B****Refer to Figure B for Steps 3-4**

Step 3: Using a pair of pliers, remove the crankcase breather hose and clamp (5) (factory clamp will be re-used).

Step 4: Using an 8mm nut driver, loosen the clamp (6) connecting the factory intake tube to the turbocharger.



Figure C

**Refer to Figure C for Step 5**

Step 5: Carefully lift up on the housing to release the two mounting pins from the mounting grommets (7).

Remove the entire intake from the vehicle.

**Figure D****Refer to Figure D for Steps 6-7**

Step 6: Slide the aFe filter into the aFe housing. Install the aFe filter using a #3 Phillips screwdriver. Tighten all (x4) screws.

Step 7: Install the supplied bellows coupling (8) onto the air filter using the supplied #80 clamp (9). Tighten the clamp using an 8mm nut driver.

**Figure E****Refer to Figure E for Steps 8-9**

Step 8: Install the aFe housing assembly into the vehicle. Firmly push the housing into the factory mounting grommets.

Step 9: Reinstall the factory nut (10) removed in Step 2 to secure the aFe housing. Tighten the screw using a 10mm socket and ratchet.

**Figure F****Refer to Figure F for Steps 10-11**

Step 10: Using a T20 Torx driver, remove the MAF sensor (11) and the TBAP sensor (12) from the factory housing.

Step 11: Using a T20 Torx driver, transfer the sensors to the aFe intake tube using the supplied M4 screws.

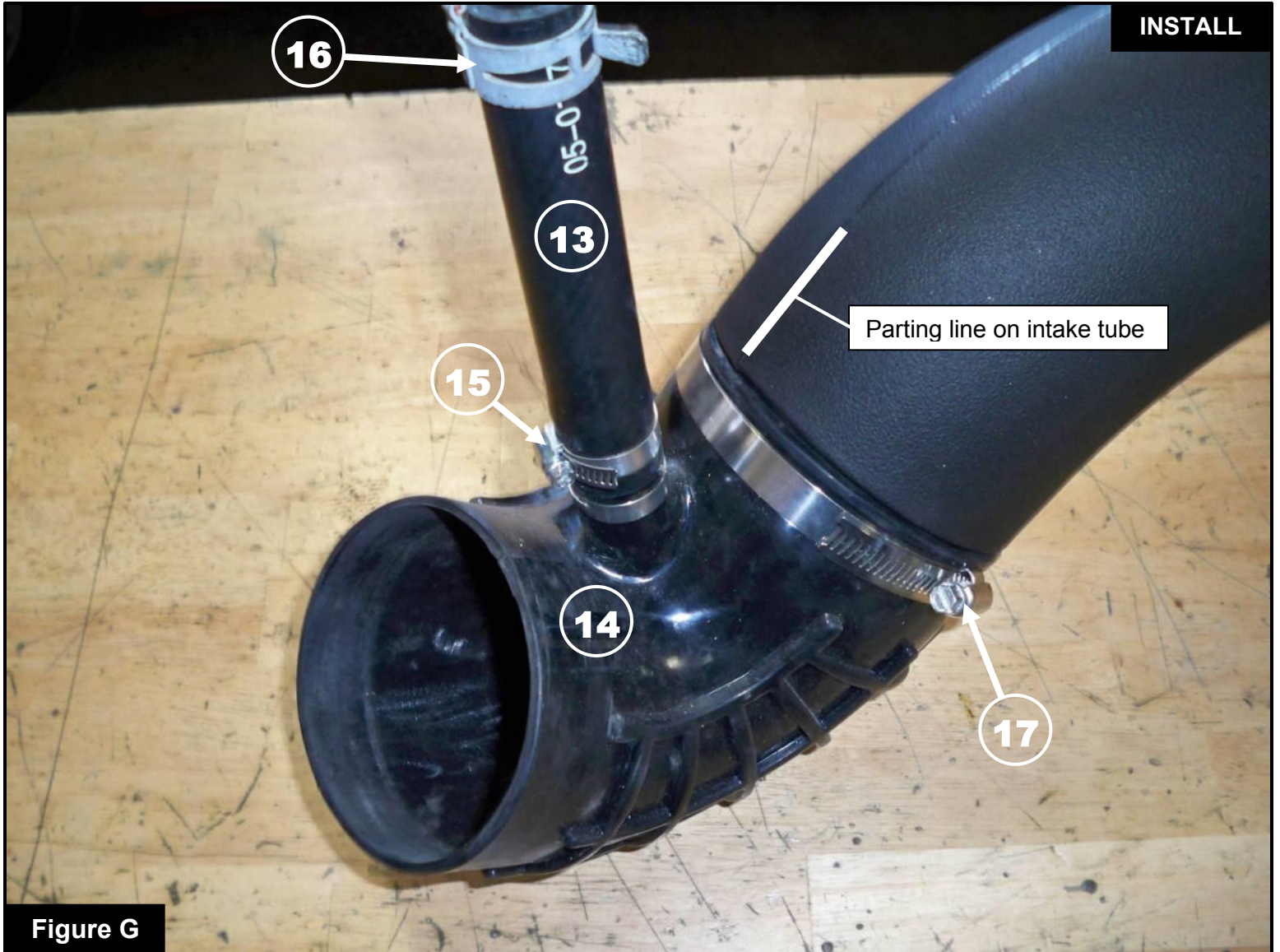

**Figure G**

**Refer to Figure G for Steps 12-14**

Step 12: Install the supplied silicone hose (13) onto the aluminum fitting on the supplied elbow coupling (14) and secure with the supplied mini clamp (15) using a flat blade screwdriver. Slide the factory clamp (16) on the other end of the silicone hose.

Step 13: Place a supplied #72 clamp (17) on the larger end of the elbow coupling.

Step 14: Install the aFe intake tube into the coupling aligning the parting line of the intake tube with the aluminum fitting on the coupling. Tighten the clamp using an 8mm nut driver.



Figure H

**Refer to Figure H for Steps 15-17**

Step 15: Place the other supplied #72 clamp (18) on the filter coupling (19).

Step 16: Place the #64 clamp (20) on the elbow coupling and install the aFe intake tube assembly onto the turbo first then slide it into the filter coupling. Align the intake tube assembly so its not too close to the exhaust, then tighten the clamps.

Step 17: Connect the silicone hose (21) to the factory crankcase breather tube. Using pliers, secure it with the factory clamp (22) removed on Step 3.



Figure I

**Refer to Figure I for Steps 18-19**

Step 18: Reconnect the MAF sensor (23) and the TBAP sensor (24) plugs.

Step 19: Check all the components are tight and secure. Your installation is now complete. Thank you for choosing aFe POWER!

**NOTE: Check all screws, clamps, and connectors are secure after 100-200 miles.**



**Page left blank intentionally**



**Page left blank intentionally**



**Page left blank intentionally**



***advanced FLOW engineering, inc.***

252 Granite Street Corona, CA 92879  
TEL: 951.493.7100 • TECH: 951.493.7134  
E-Mail: [Tech@aFepower.com](mailto:Tech@aFepower.com)