

advanced FLOW engineering Rapid Induction Cold Air Intake System

Instruction Manual P/N: 52-10011D / 52-10011R

| | | | |
|-------------------|------------------------------------|------------------------|------------------------------------|
| Make: MINI | Model: Cooper/S (F55/56/57) | Year: 2019-2021 | Engine: L4-2.0L (t) B36/B46 |
| Make: MINI | Model: Countryman/S (F60) | Year: 2019-2021 | Engine: L4-2.0L (t) B36/B46 |
| Make: MINI | Model: Clubman/S (F54) | Year: 2019-2021 | Engine: L4-2.0L (t) B36/B46 |
| Make: BMW | Model: X1 (F48) | Year: 2019-2021 | Engine: L4-2.0L (t) B46 |
| Make: BMW | Model: X2 (F39) | Year: 2019-2021 | Engine: L4-2.0L (t) B46 |
| Make: BMW | Model: 228i (F44) | Year: 2020-2021 | Engine: L4-2.0L (t) B46 |



- Please read the entire instruction manual before proceeding.
- Ensure all components listed are present.
- For technical support please call at 951-493-7185.
- Ensure you have all necessary tools before proceeding.
- Do not attempt to work on your vehicle when the engine is hot.
- Retain factory parts for future use.

| Label | Qty. | Description | Part Number |
|-------|------|---------------------------|--------------|
| A1 | 1 | Air Filter (Pro DRY S) | 21-30506 |
| A2 | 1 | Air Filter (Pro 5R) | 24-30506 |
| B | 1 | Tube and Housing Assembly | 05-5210011B1 |
| C | 1 | Seal, Trim, 33" Length | 05-00072 |
| D | 2 | Screw, M4 | 03-50490 |

Installation will require the following tools:

6mm and 8mm nut drivers or sockets, socket wrench, flat-head screwdriver, T20 and T25 torx bit.

Warranty information available at <https://afepower.com/contact#warranty>.

Emissions Disclaimer:

This product is not currently CARB exempt and is not available for purchase in California or for use on any vehicle registered with the California Department of Motor Vehicles.

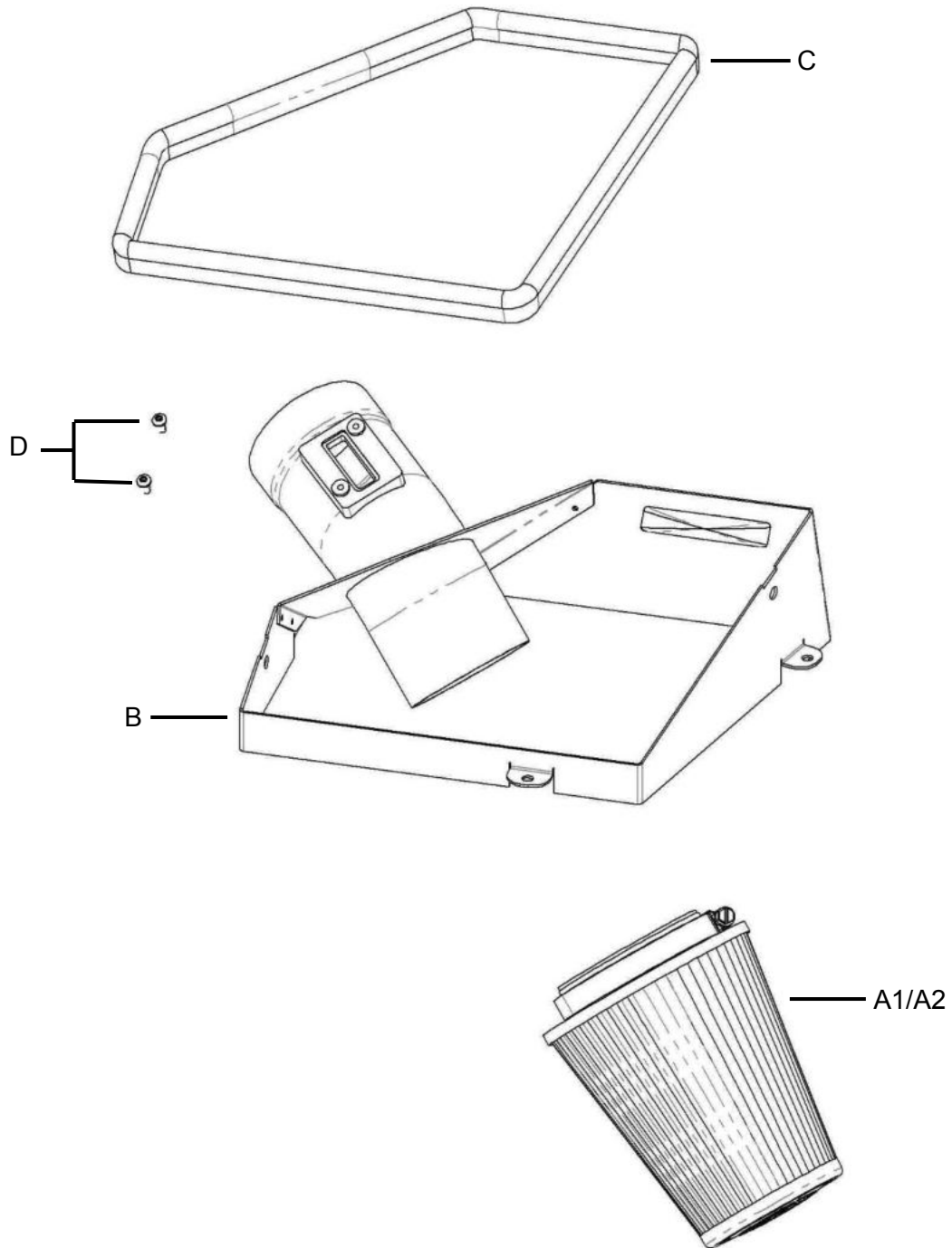

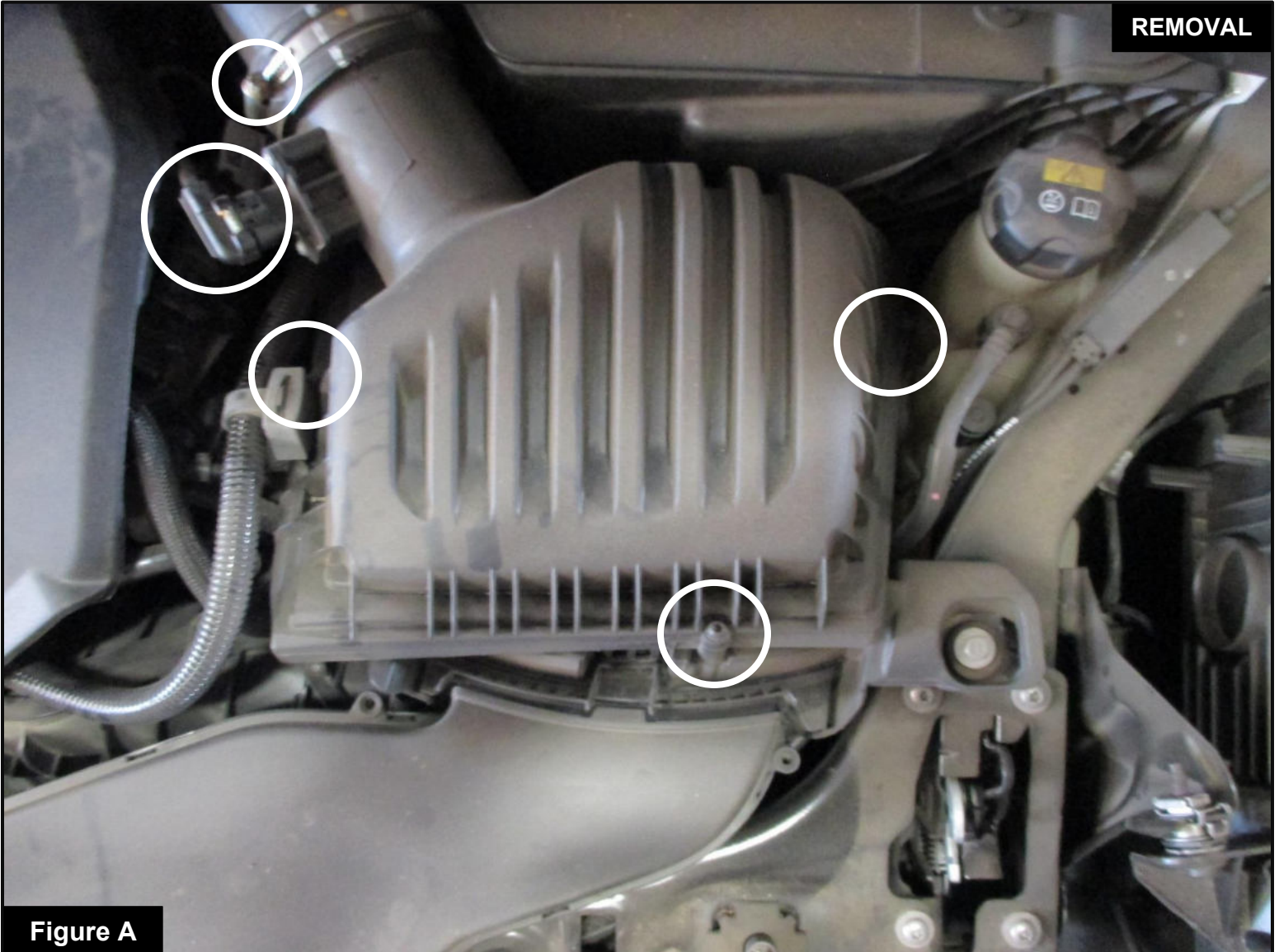
**Figure A****Refer to Figure A for Steps 1-5**

Step 1: Disconnect the mass air flow (MAF) sensor harness.

Step 2: Using a 6mm nut driver, loosen the hose clamp at the factory airbox. Then, slide the factory intake tube away from the factory airbox.

Step 3: Using a T25 torx bit driver, remove the three (3) factory screws from the factory airbox. These screws will be re-used.

Step 4: Remove the top half of the factory airbox by carefully pulling up.

Step 5: Remove the factory air filter from the vehicle.

**Figure B****Refer to Figure B for Steps 6-8**

Step 6: Transfer the MAF sensor from the factory airbox into the aFe POWER intake tube using the provided screws.

Step 7: Install the provided seal trim on the top edge of the aFe POWER intake housing.

Step 8: Install the provided air filter into the aFe POWER intake tube and tighten the clamp.

**Figure C****Refer to Figure C for Steps 9-13**

Step 9: Install the aFe POWER intake housing into the vehicle by placing it on top of the factory airbox, then sliding the tube end into the factory intake tube. Do not tighten the clamp at this time.

Step 10: Using the three (3) screws removed from **Step 3**, tighten down the aFe POWER intake housing into the bottom half of the factory airbox.

Step 11: Tighten the clamp between the factory intake tube and the aFe POWER intake tube.

Step 12: Connect the MAF sensor to the harness.

Step 13: Make sure all components and connections are secure. Your installation is now complete. Thank you for choosing aFe POWER!

NOTE: Check all bolts, clamps, and connectors after 100-200 miles.



Page left blank intentionally



advanced FLOW engineering, inc.

252 Granite Street Corona, CA 92879

<https://afepower.com/contact>