

advanced FLOW engineering

Cold Air Intake System

Instruction Manual P/N: 52-10016D / 52-10016R

Make: MERCEDES-BENZ	Model: CLA 250	Year: 2014-2019	Engine: L4-2.0L(t)
Make: MERCEDES-BENZ	Model: GLA 250	Year: 2014-2020	Engine: L4-2.0L(t)
Make: MERCEDES-BENZ	Model: A250	Year: 2012-2018	Engine: L4-2.0L(t)
Make: MERCEDES-BENZ	Model: B250	Year: 2012-2018	Engine: L4-2.0L(t)
Make: INFINITI	Model: QX30	Year: 2017-2019	Engine: L4-2.0L(t)
Make: INFINITI	Model: Q30	Year: 2015-2019	Engine: L4-2.0L(t)



- Please read the entire instruction manual before proceeding.
- Ensure all components listed are present.
- For technical support please call at 951-493-7185.
- Ensure you have all necessary tools before proceeding.
- Do not attempt to work on your vehicle when the engine is hot.
- Retain factory parts for future use.

Label	Qty.	Description	Part Number
A	1	Air Filter (Pro DRY S) for 52-10016D	21-91117
A	1	Air Filter (Pro 5R) for 52-10016R	24-91117
B	1	Tube	05-5210016B1
C	1	Housing	05-5210016B2
D	1	Seal, Trim: 7/16" bulb (22" Length)	05-00072
E	4	Screw, Phillips Rounded Head: #8 x 5/8"	03-50392

Installation will require the following tools:

7mm and 8mm Nut Drivers /Sockets and Ratchet, Phillips Screwdriver, T25 Driver

Warranty information available at <https://afepower.com/contact#warranty>.

Emissions Disclaimer:

This product is not currently CARB exempt and is not available for purchase in California or for use on any vehicle registered with the California Department of Motor Vehicles.

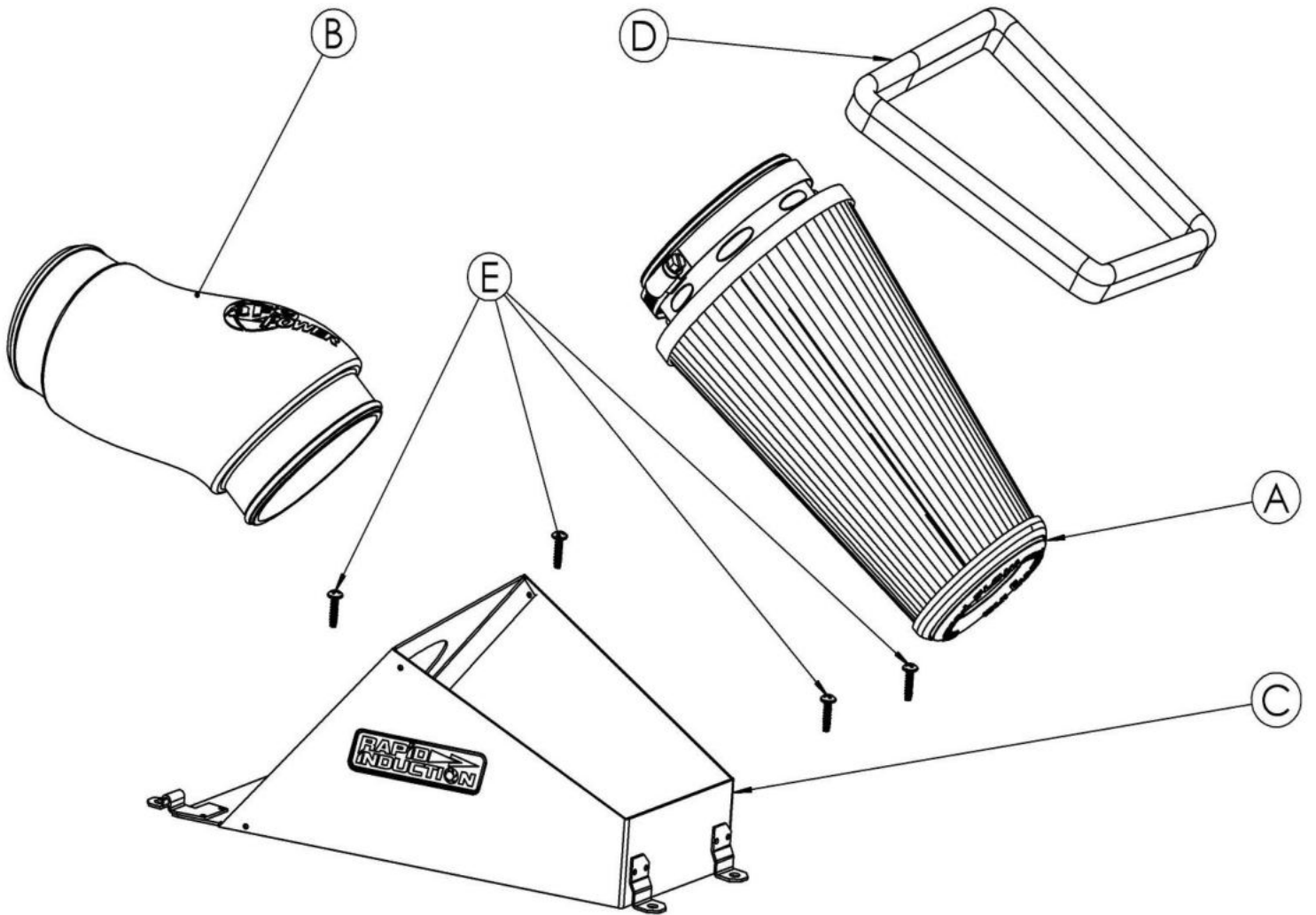

**Figure A****Refer to Figure A for Step 1**

Step 1: Remove the engine cover by pulling it upward.

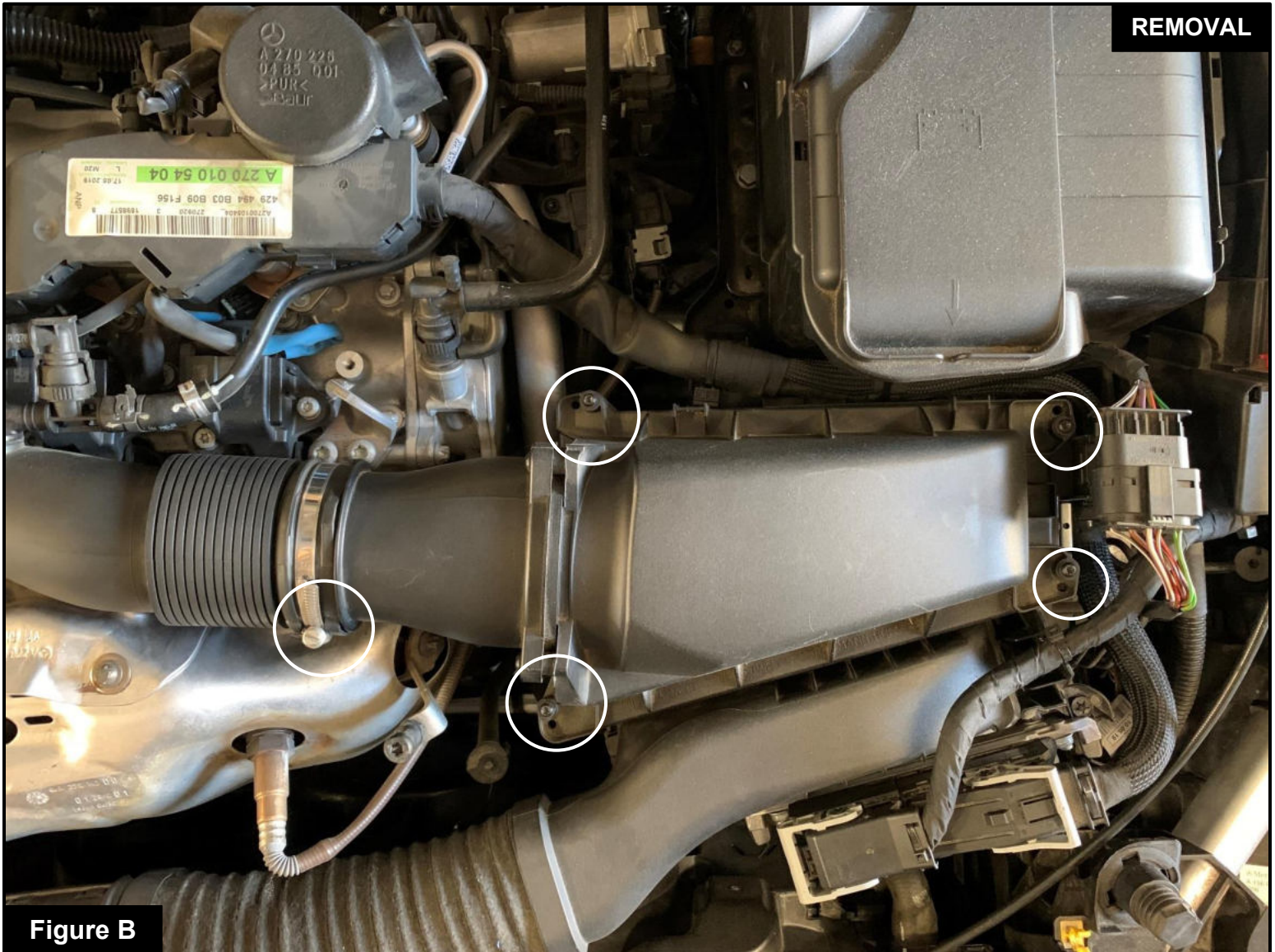

Figure B

Refer to Figure B for Steps 2-3

Step 2: Loosen the clamp securing the intake tube to the turbo inlet.

Step 3: Remove the 4 screws securing the top of the air box using a T25 driver, and then remove the top of the air box from the vehicle.

**Figure C****Refer to Figure C for Steps 4-5**

Step 4: Install the supplied seal trim around the top edge of the Rapid Induction housing.

Step 5: Install the filter from the inside of the housing and place the clamp on the filter flange, do not tighten the clamp. Make sure the filter retention bumps hold it in place.

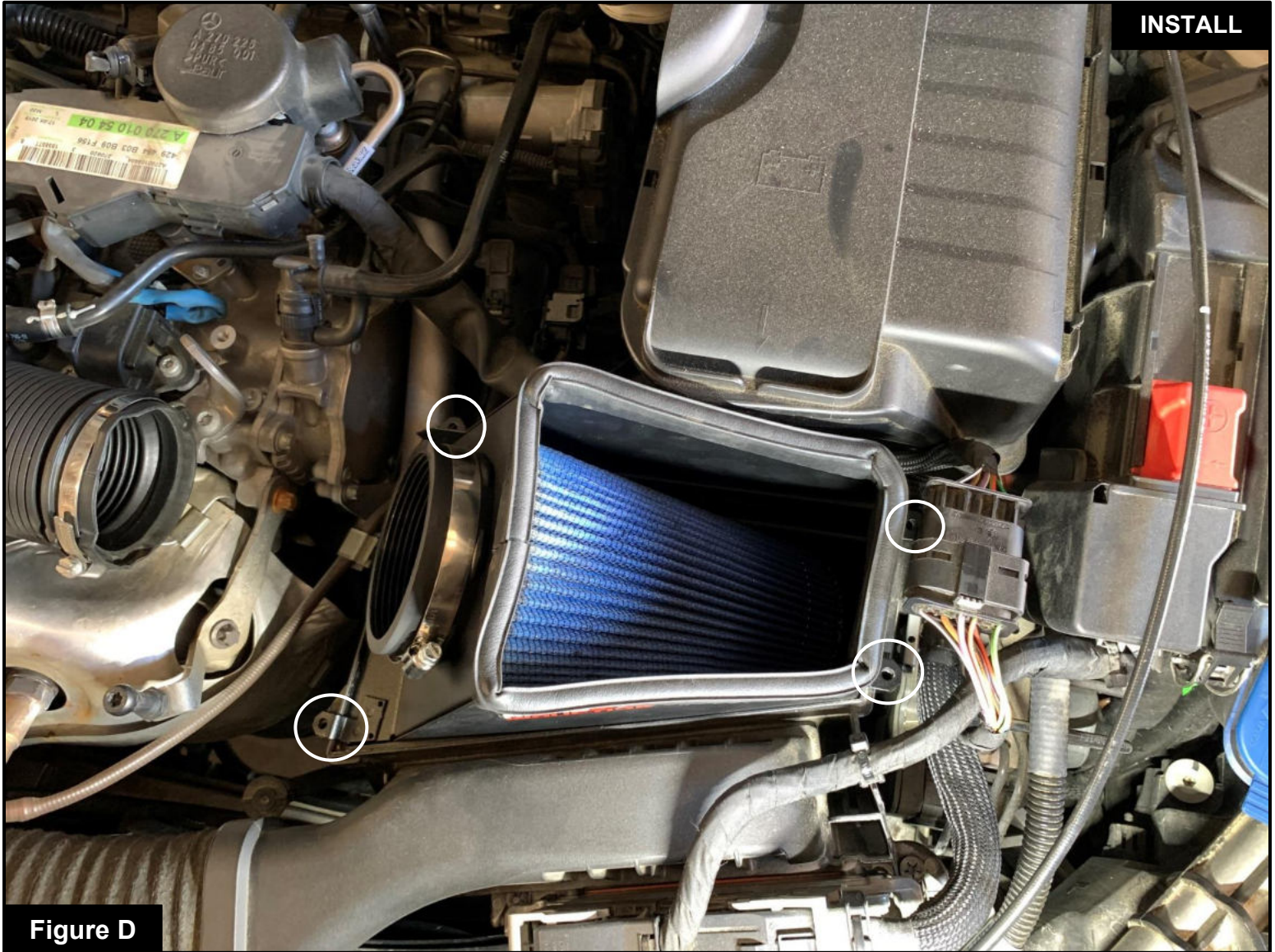

Figure D

Refer to Figure D for Step 6

Step 6: Install the Rapid Induction housing onto the bottom half of the factory air box and secure it with the 4 provided Phillips head screws.



Figure E

Refer to Figure E for Steps 7-8

Step 7: Install the aFe POWER tube, by sliding it into the turbo inlet side first, then into the air filter.

Step 8: Tighten both of the clamps.



Refer to Figure F for Step 9

Step 9: Reinstall the engine cover. Your installation is complete. Thank You for choosing aFe POWER!

NOTE: Check all bolts, clamps, and connectors after 100-200 miles.



Page Left Blank Intentionally



Page Left Blank Intentionally



advanced FLOW engineering, inc.

252 Granite Street Corona, CA 92879

<https://afepower.com/contact>