

advanced FLOW engineering Super Stock Air Intake System

Instruction Manual P/N: 55-10006D / 55-10006R

Make: Ford

Model: Mustang

Year: 2015-2020

Engine: L4-2.3L(t) EcoBoost



- Please read the entire instruction manual before proceeding.
- Ensure all components listed are present.
- For technical support please call 951-493-7185.
- Ensure you have all necessary tools before proceeding.
- Do not attempt to work on your vehicle when the engine is hot.
- Retain factory parts for future use.

Label	Qty.	Description	Part Number
A1	1	Air Filter (Pro 5R)	30-10255
A2	1	Air Filter (Pro DRY S)	31-10255
B	1	Tube	05-5510006B1
C	1	Coupling, Silicone Bellow: 3-3/4"ID x 3"L	05-01509
D	1	Coupling, Silicone Straight: (3"x2-1/2")ID x 3"L	05-01333
E	2	Clamp, T-bolt (3-13/16" - 4-1/8") (SS)	03-50265
F	1	Clamp, T-bolt (3-1/16" - 3-3/8") (SS)	03-50320
G	1	Fitting, Vent Tube (Large)	05-01339
H	1	Clamp, 044 (2-5/16" - 3-1/4")	03-50019

Installation will require the following tools:

Pliers or spring clamp tool, 7mm and 8mm nut drivers, 11mm deep socket and driver, and adjustable wrench.

Emissions Disclaimer: This product is not currently CARB exempt and is not available for purchase in California or for use on any vehicle registered with the California Department of Motor Vehicles.

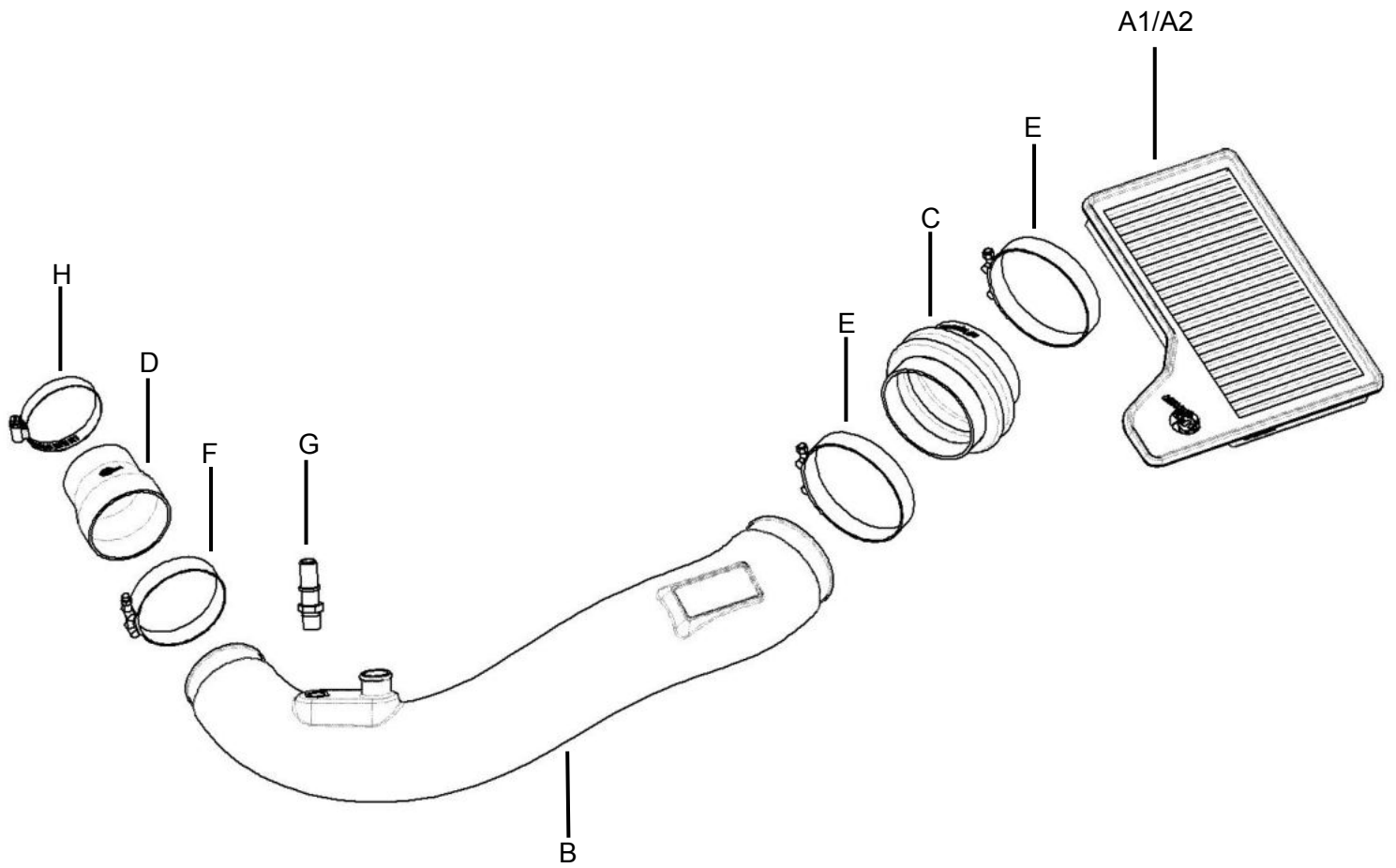

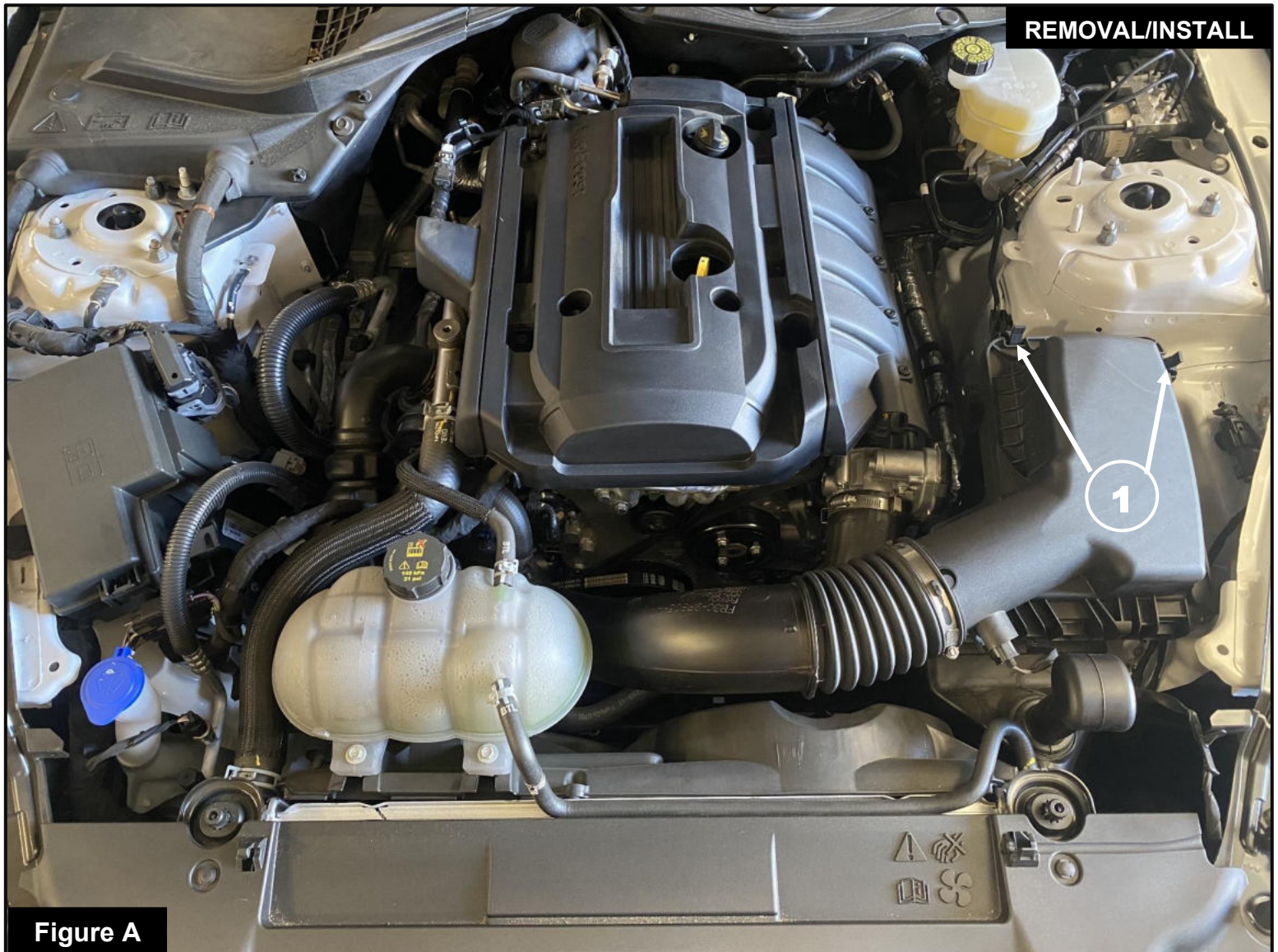

Refer to Figure A for Steps 1-5

Step 1: Release the two clamps ① that secure the factory upper housing.

Step 2: Lift the factory air filter from the factory lower housing and remove.

Step 3: Clean any dirt and debris from the factory air filter housing to make sure no dirt enters the engine.

Step 4: Install the aFe POWER OER air filter. Be careful when installing not to crimp the edges of the aFe POWER air filter between the factory upper and lower housing. This could cause air filter damage and allow unfiltered air to enter the engine if not properly seated.

Step 5: Replace the factory upper housing by engaging the two clamps ① to secure the factory upper housing to the factory lower housing.

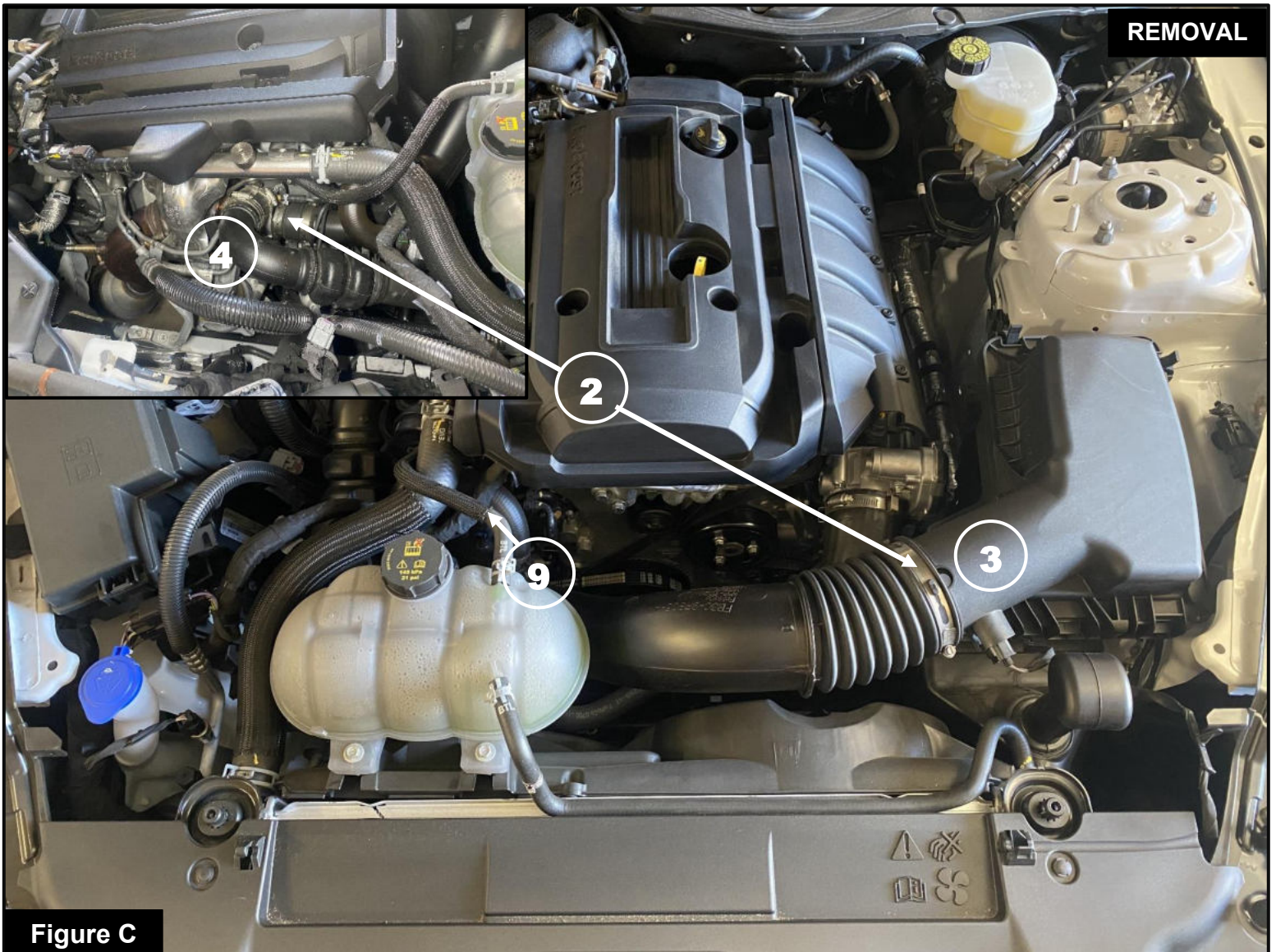
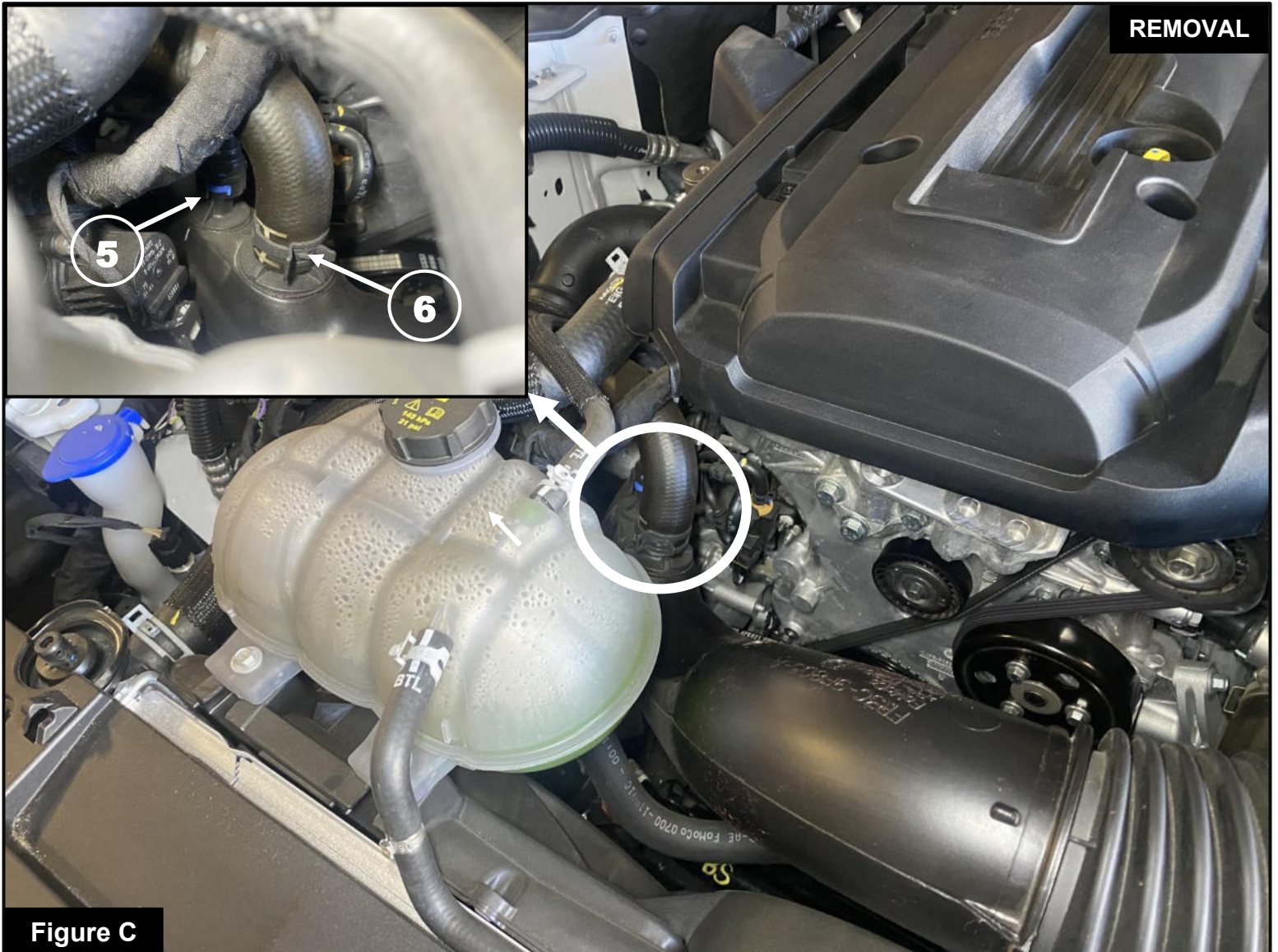

Figure C

Refer to Figure C for Step 6

Step 6: Locate the two factory clamps (2) on the factory intake tube. Using a 7mm nut driver, loosen the clamps at the housing (3) and at the turbo inlet (4).



Refer to Figure C for Steps 7-9

Step 7: Disconnect the vent fitting (5) on the back of the intake tube.

Step 8: Using a pair of pliers (or a spring clamp tool), remove the spring clamp (6) from the 1.00" diameter rubber hose. Keep the spring clamp on the rubber hose because it will be reused in a later step.

Step 9: Remove the factory intake tube from the vehicle.

**Figure D****Refer to Figure D for Steps 10-12**

Step 10: Install large vent tube fitting (7) into the location shown on the aFe POWER intake tube and tighten them using an adjustable wrench.

***NOTE:** Exposed threads shown are normal. This is an NPT thread.

Step 11: Install the silicone wrapped coupling (8) onto the aFe POWER intake tube in the location shown and snug (but do not tighten) the (TB337SS) clamp using the 11mm deep socket and driver.

Step 12: Install the silicone bellows coupling (9) onto the aFe POWER intake tube in the location shown and snug (but do not tighten) the (TB412SS) clamp using the 11mm deep socket and driver.

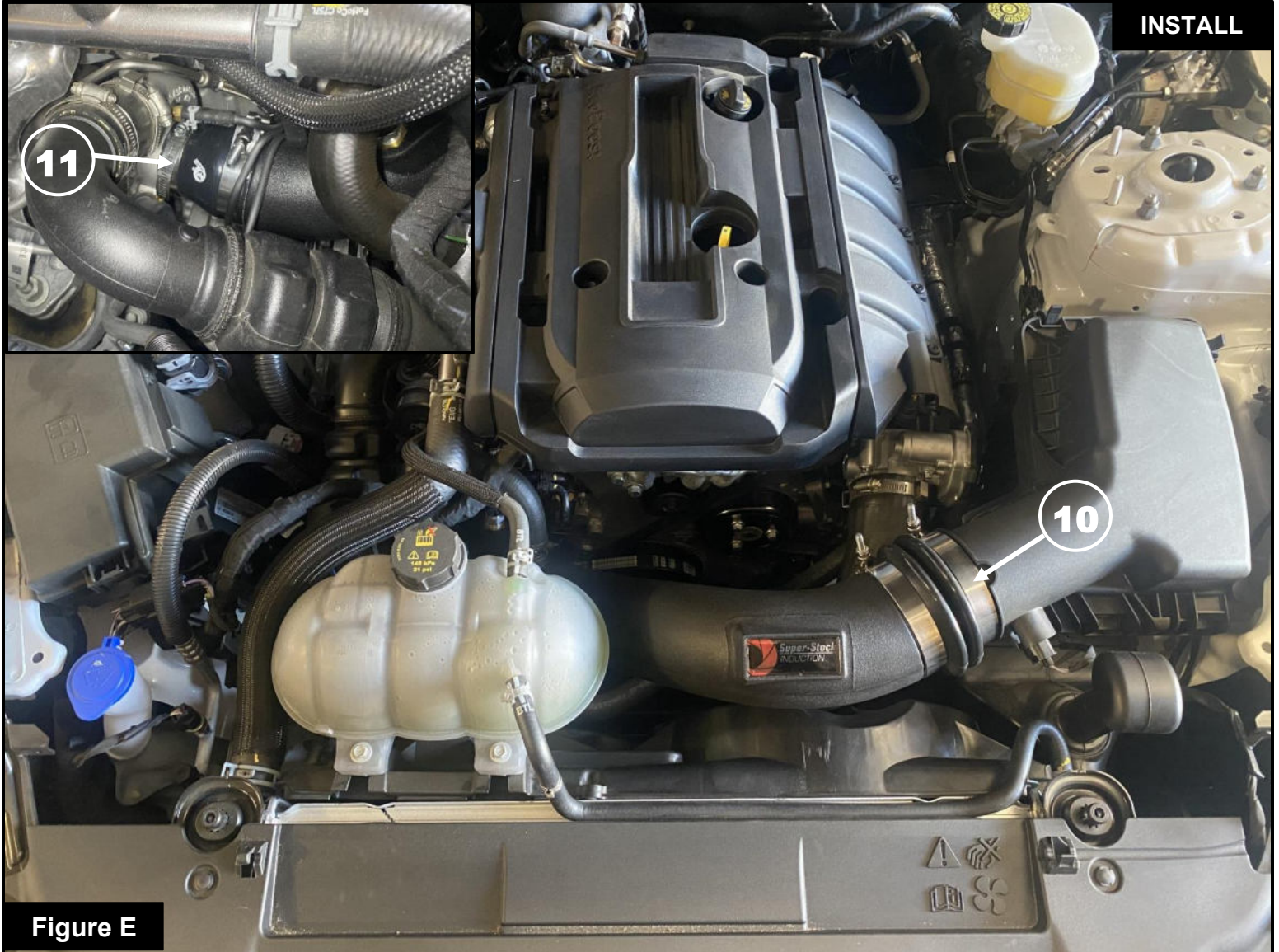

Figure E

Refer to Figure E for Steps 13-15

Step 13: Slip the clamp (TB412SS) onto the silicone bellows coupling ⑩ and clamp (#044) onto the silicone wrapped coupling ⑪.

Step 14: Install the aFe POWER intake tube by slipping the silicone bellows coupling onto the factory housing and snug (but do not tighten) the (TB412SS) clamp using the 11mm deep socket and driver.

Step 15: Slip the silicone wrapped coupling onto the turbo inlet and snug (but do not tighten) the (#044) clamp using the 8mm nut driver.



Refer to Figure E for Steps 16-17

Step 16: Connect the large vent tube fitting (12) to the aFe POWER intake tube.

Step 17: Reconnect the 1.00" diameter rubber hose to the aFe POWER intake tube and secure it with the factory spring clamp from step 8. Make sure all fittings and hoses are fully seated and will not disconnect.



Refer to Figure E for Step 18

Step 18: Align the aFe POWER intake tube and couplings, then tighten the clamps. Your install is now complete!

NOTE: Check all bolts, clamps, and connectors after 100-200 miles.



Page Left Blank Intentionally



Page Left Blank Intentionally



Page Left Blank Intentionally

Pro DRY S Air Filter



P/N: 31-10255

Pro 5R Air Filter



P/N: 30-10255

Pro DRY S Restore Kit



P/N: 90-59999

Blue Squeeze Restore Kit



P/N: 90-50501

Lowering Springs



P/N: 410-301001-N

aFe Control Sway Bar Set



P/N: 440-301001-N

Sprint Booster V3



P/N: 77-13005

Pro GUARD HD Oil Filter



P/N: 44-LF038

Intercooler Tubes



P/N: 46-20254-B
46-20254-L

aFe Fender Cover



P/N: 40-10230

Mach Force Axle Back Exhaust



P/N: 49-43085-B (Blk. Tips)
49-43085-P (Pol. Tips)

Mach Force Cat-Back Exhaust



P/N: 49-33084-B (Blk. Tips)
49-33084-P (Pol. Tips)



To purchase any of the items above, view airflow charts, dyno graphs, photos, and video; please go to aFepower.com.

Warranty

General Terms:

- aFe warrants their products to be free from manufacturer’s defects due to workmanship and material.
- This warranty applies only to the original purchaser of the product and is non-transferrable.
- Proof of purchase of the aFe product is required for all warranty claims.
- Warranty is valid provided aFe instructions for installation and/or cleaning were properly followed.
- Proper maintenance with regular inspections of product is required to insure warranty coverage.
- Damage due to improper installation, abuse, unauthorized repair or alteration is not warranted.
- Incidental or consequential damages or cost, including installation and removal of part, incurred due to failure of aFe product is not covered under this warranty.
- All warranty is limited to the repair and/or replacement of the aFe part. To request Return Goods Authorization (“RGA”), email RGA@afepower.com or call (951)493-7100. Upon receipt of the RGA, you must return the product to the address provided in the RGA, freight prepaid and accompanied with a dated proof of purchase and the RGA. Upon receipt of the defective product and upon verification of proof of purchase, aFe will either repair or replace the defective product within a reasonable time, not to exceed thirty days.

Product Category	P/N Prefix	Warranty duration
Direct OE Replacement Filters	10, 11, 30, 31, 71, 73	Life of the vehicle
Racing Filters	18	1 year
Universal	20, 21, 23, 24, 72, TF	2 years
Air Intake Systems	50, 51, 53, 54, 55, 56, 57, 58, 75, TR, TA, TL, TM	2 years
Exhaust Systems	49	2 years
Intercoolers & Intercooler Tubes	46-2	2 years
Intake Manifolds	46-1	2 years
Differential Cover	46-7	Life of the vehicle
Exhaust Manifolds	46	2 years
Throttle Body Spacers	46-3	2 years
Turbochargers	46-6	2 years*
Fluid Filters	44	90 days
Pre-Filters	28	2 years
Heavy Duty OE Replacement	70	2 years
PowerSports OE Replacement	81, 87	2 years
PowerSports Intake Systems	85	2 years

No other warranty expressed or implied applies nor is any person or advanced FLOW engineering authorized to assume any other warranty. Some States do not allow the exclusion or limitation of incidental or consequential damages or do not allow limitations on how long an implied warranty lasts, so the above limitations or exclusions may not apply to you. This warranty gives you specific legal rights, and you may also have other rights which vary from State to State.

*See turbocharger warranty for more info



advanced FLOW engineering, inc.

252 Granite Street Corona, CA 92879
TEL: 951.493.7100 • TECH: 951.493.7134
E-Mail: Tech@aFepower.com

P/N: 06-81408