

advanced FLOW engineering

Cold Air Intake System

Instruction Manual P/N: 55-10002D / 55-10002R

Make: Toyota

Model: Tacoma

Year: 2016-2022

Engine: V6-3.5L



- Please read the entire instruction manual before proceeding.
- Ensure all components listed are present.
- For technical support please call 951-493-7185.
- Ensure you have all necessary tools before proceeding.
- Do not attempt to work on your vehicle when the engine is hot.
- Retain factory parts for future use.

Label	Qty.	Description	Part Number
A1	1	Air Filter (Pro 5R)	30-10247
A2	1	Air Filter (Pro DRY S)	31-10247
B	1	Tube	05-5510002B1
C	1	Coupling, Silicone Bellow: (3"-3-1/8")ID x 3"L	05-01400
D	1	Coupling, Silicone Elbow: (3-1/2"x3-1/4")IDx 15Deg	05-0458
E	3	Clamp, #048 (2-9/16" - 3-1/2 ")	03-50007
F	1	Clamp, #052 (2-13/16" - 3-3/4")	03-50008

Installation will require the following tools:

8mm & 10mm nut drivers

Warranty Information available at <https://afepower.com/contact#warranty>

Emissions Disclaimer: This product is not currently CARB exempt and is not available for purchase in California or for use on any vehicle registered with the California Department of Motor Vehicles.

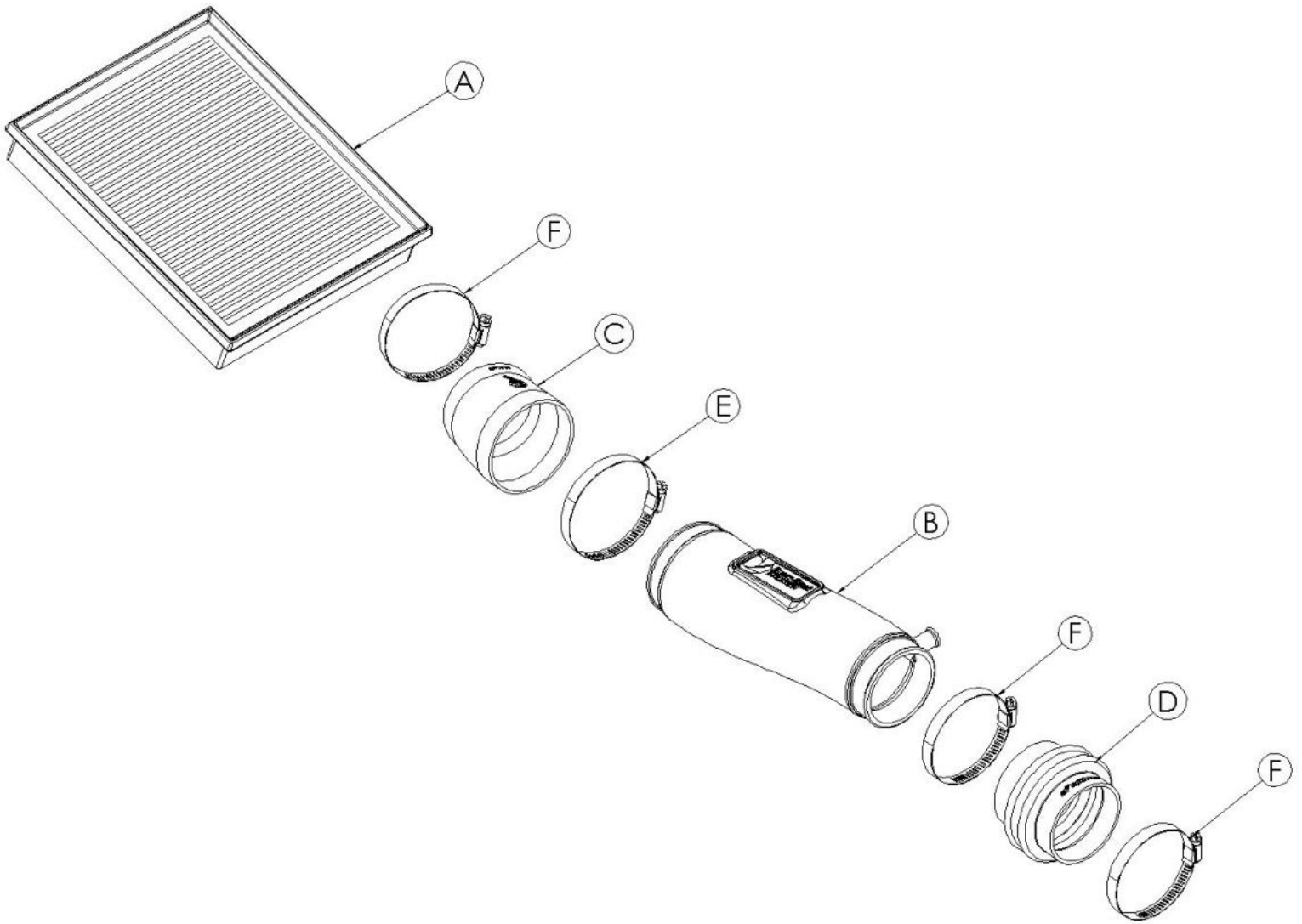

**Figure A****Refer to Figure A for Step 1**

Step 1: Remove the engine cover ①.

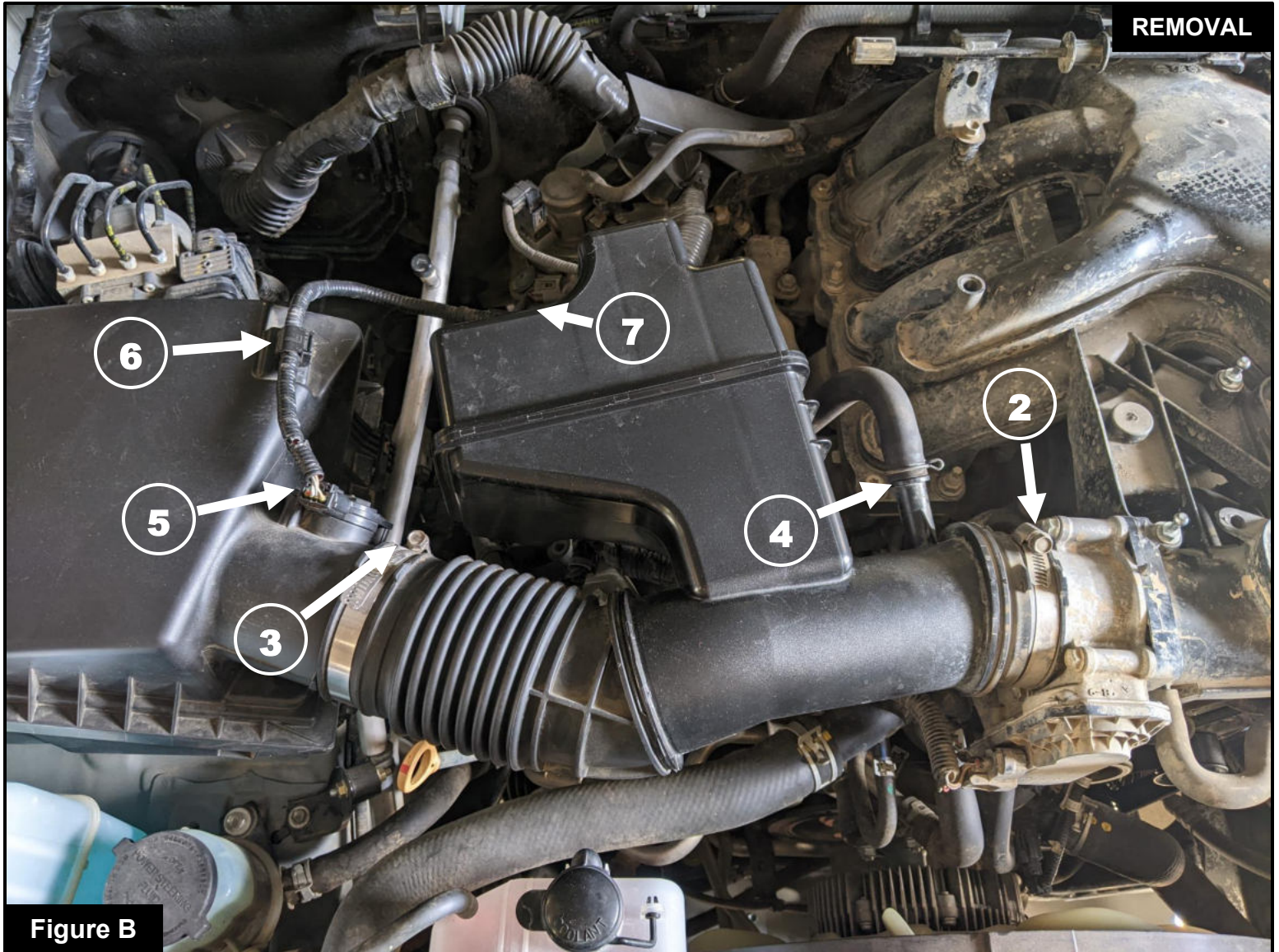

Figure B

Refer to Figure B for Steps 2-6

Step 2: Using a 10mm nut driver, loosen the clamp at the throttle body (2) and at the factory airbox cover (3).

Step 3: Loosen the pinch clamp and disconnect the CCV hose (4).

Step 4: Disconnect the Mass Airflow (MAF) sensor (5).

Step 5: Unclip the MAF sensor wire harness from the top of the factory airbox (6) and the factory intake resonance chamber (7).

Step 6: Remove the factory intake tube.

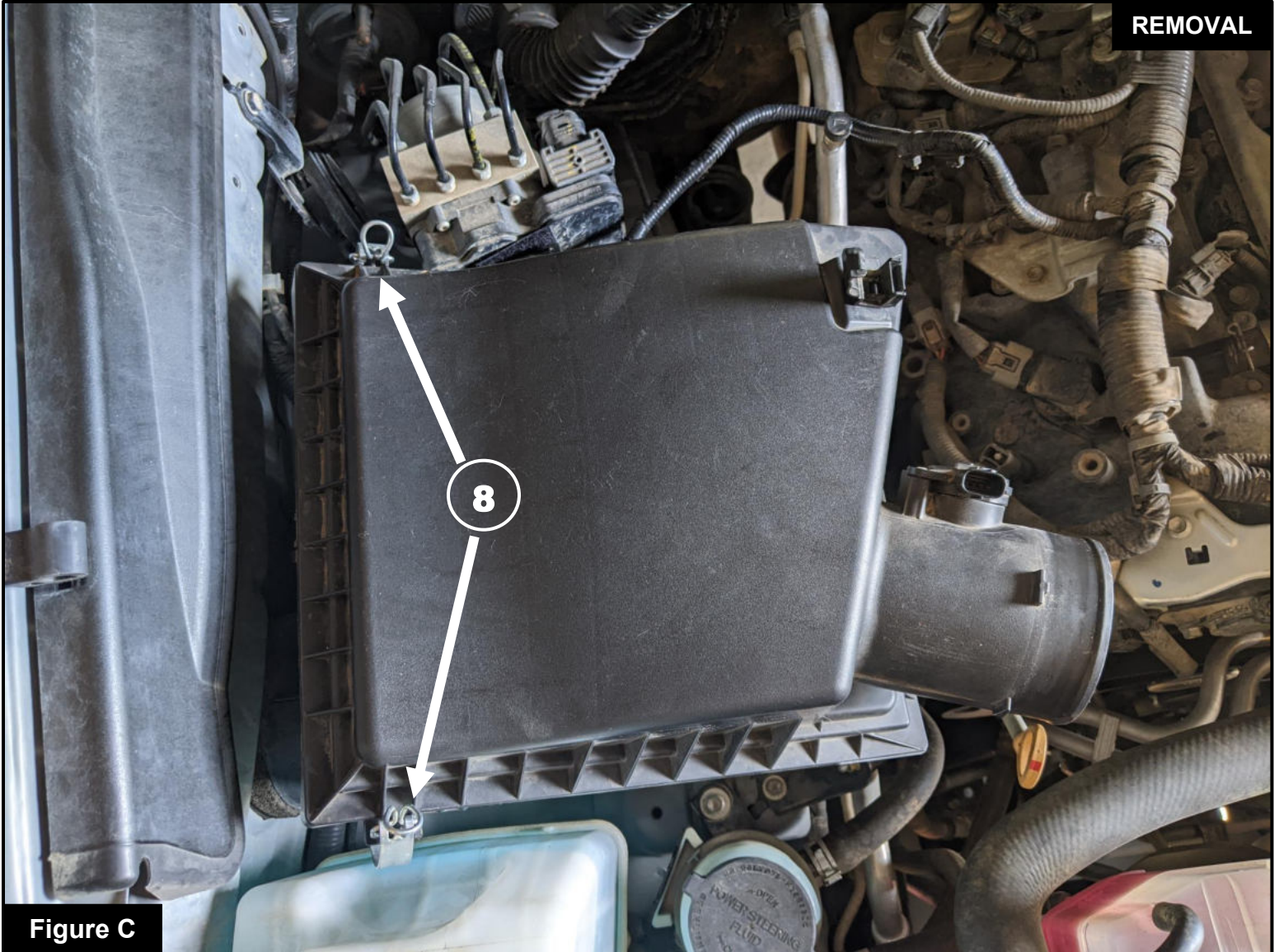
**Figure C****Refer to Figure C for Step 7**

Step 7: Disengage the two (2x) clips ⑧ on the top side of the factory airbox, then remove the lid.



Refer to Figure D for Steps 8-9

Step 8: Remove your factory engine air filter and replace with your aFe POWER Magnum FLOW air filter.

Step 9: Replace the top of the factory airbox and re-engage the clips.

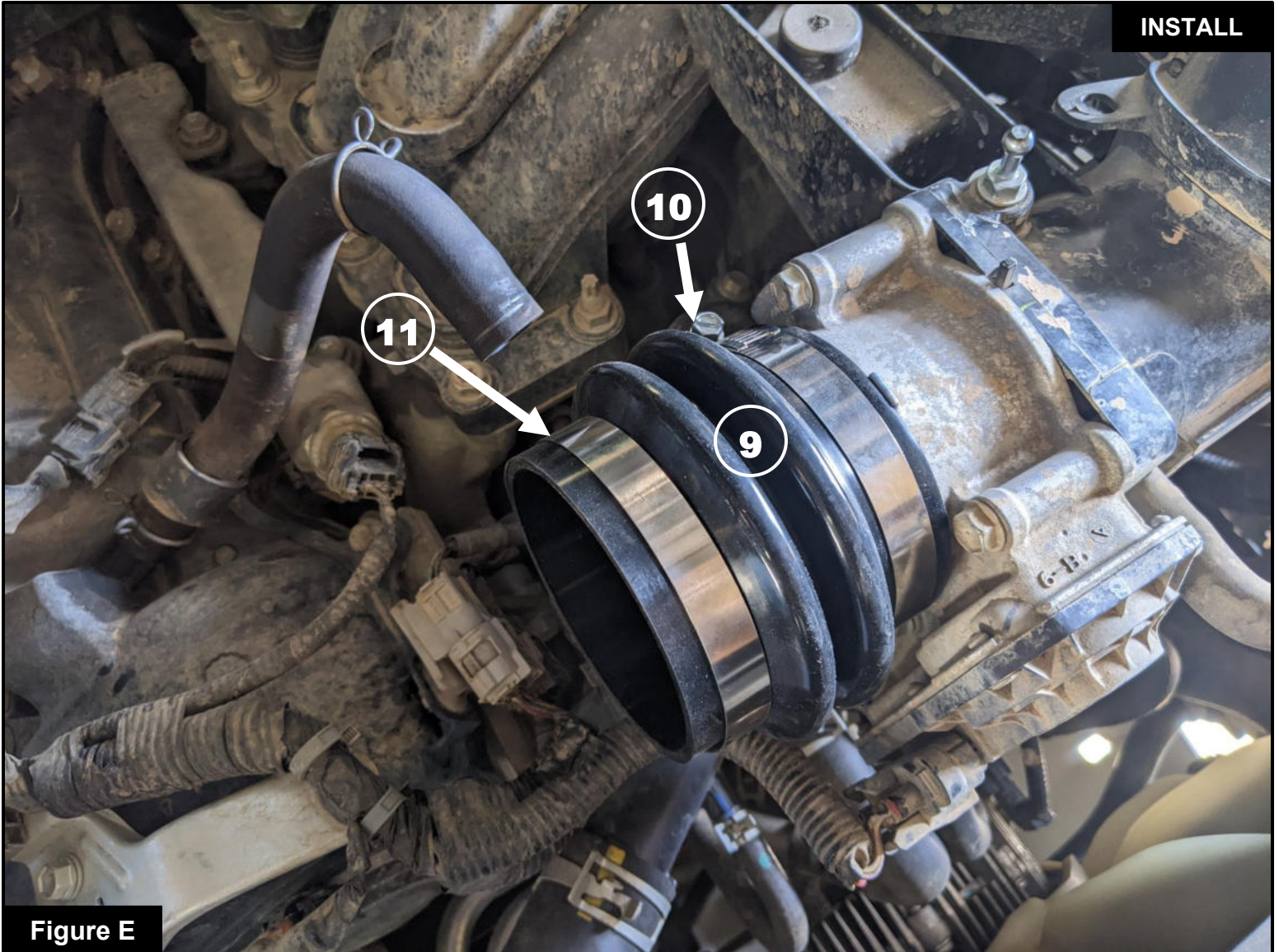
**Figure E****Refer to Figure E for Steps 10-11**

Step 10: Install the supplied bellows coupling (9) with the “aFe POWER” logo on the throttle body along with one (1x) #048 clamp (10) . Tighten the clamp on the throttle body using an 8mm nut driver.

Step 11: Place another #048 clamp (11) on the open end of coupling. Do not tighten.

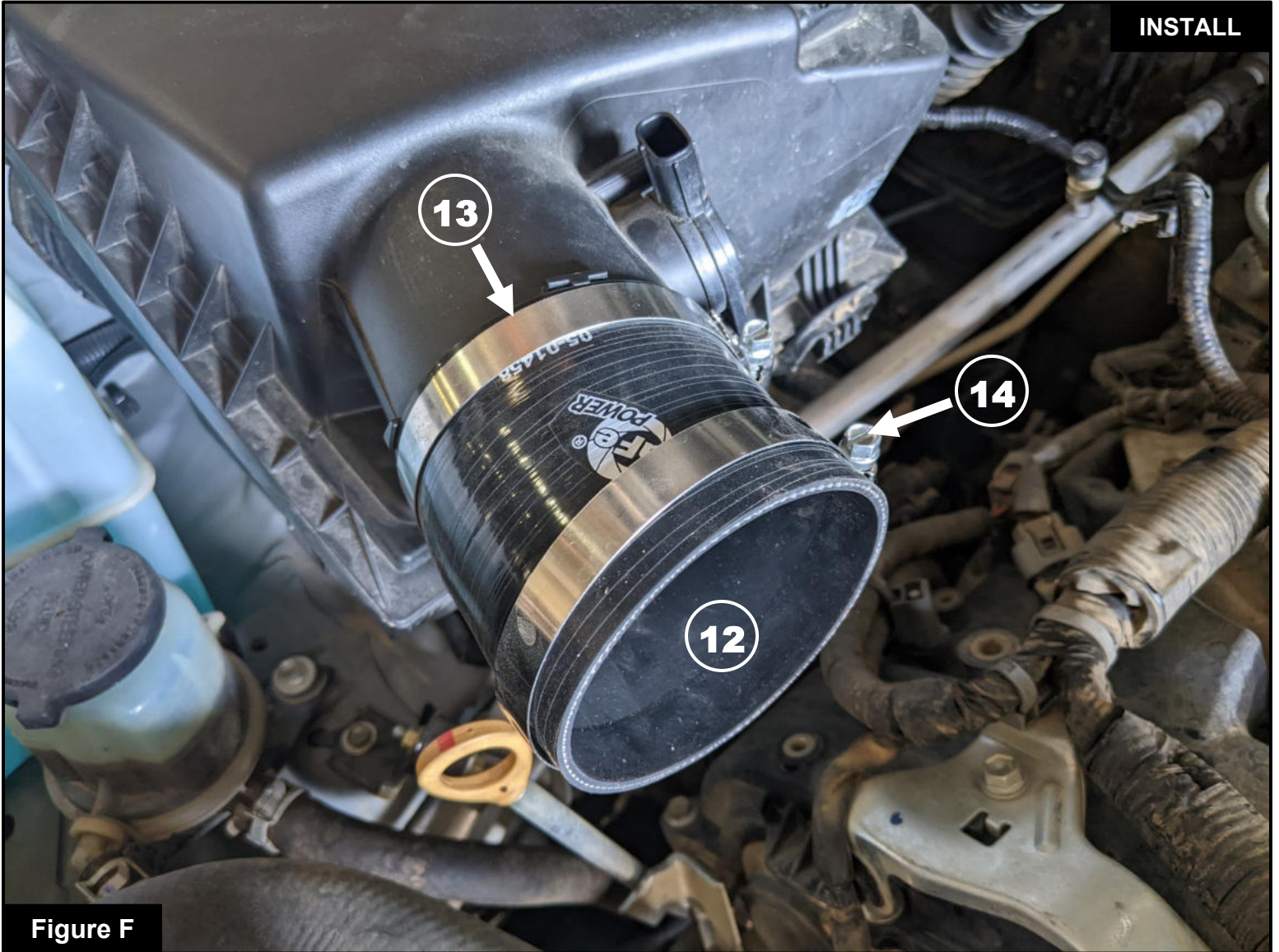
**Figure F****Refer to Figure F for Steps 12-13**

Step 12: Install the supplied reducer elbow coupling (12) with the remaining #048 clamp (13) on the factory airbox as shown. Leave the clamp loose.

Step 13: Place the #052 clamp (14) loosely on the open end of the coupler.

**Figure G****Refer to Figure G for Steps 14-16**

Step 14: Install your aFe POWER intake tube first into the bellow coupling at the throttle body, then into the elbow coupling at the factory airbox. Rotate the coupling at the factory airbox until both ends align, then tighten all clamps using an 8mm nut driver.

Step 15: Reconnect the CCV hose (15).

Step 16: Reconnect the MAF sensor (16) and the wire loom (17).

**Figure H****Refer to Figure H for Step 17**

Step 17: Reinstall your engine cover.

Your installation is now complete. Thank you for choosing aFe POWER!

NOTE: Check all screws, clamps, and connectors are secure after 100-200 miles



advanced FLOW engineering, inc.

252 Granite Street Corona, CA 92879

<https://afepower.com/contact>