

advanced FLOW engineering Super Stock Air Intake System

Instruction Manual P/N: 55-10009D / 55-10009R

Make: Jeep
Make: Jeep

Model: Wrangler (JL)
Model: Gladiator (JT)

Year: 2018-2021
Year: 2020-2021

Engine: V6-3.6L
Engine: V6-3.6L



- Please read the entire instruction manual before proceeding.
- Ensure all components listed are present.
- For technical support please call 951-493-7185.
- Ensure you have all necessary tools before proceeding.
- Do not attempt to work on your vehicle when the engine is hot.
- Retain factory parts for future use.

| Label | Qty. | Description | Part Number |
|-------|------|---|--------------|
| A1 | 1 | Air Filter (Pro 5R) | 30-80280 |
| A2 | 1 | Air Filter (Pro DRY S) | 31-80280 |
| B | 1 | Tube | 05-5510009B1 |
| C | 1 | Coupling, Silicone Bellow: 3-1/4"ID x 2-1/2"L | 05-01416 |
| D | 1 | Coupling, Silicone Bellow: 3-1/4"ID x 3"L | 05-01480 |
| E | 4 | Clamp, 048 (2-9/16" – 3-1/2") | 03-50007 |
| F | 1 | Grommet, Rubber | 03-50167 |
| G | 1 | Fitting, Air Temp Sensor | 05-01454 |
| H | 1 | Fitting, Vent Tube | 05-01339 |

Installation will require the following tools:

8mm nut driver, 8mm/10mm deep socket and driver, cutting pliers, adjustable wrench, panel popper tool.

Warranty Information available at <https://afepower.com/contact#warranty>

Emissions Disclaimer: This product is not currently CARB exempt and is not available for purchase in California or for use on any vehicle registered with the California Department of Motor Vehicles.

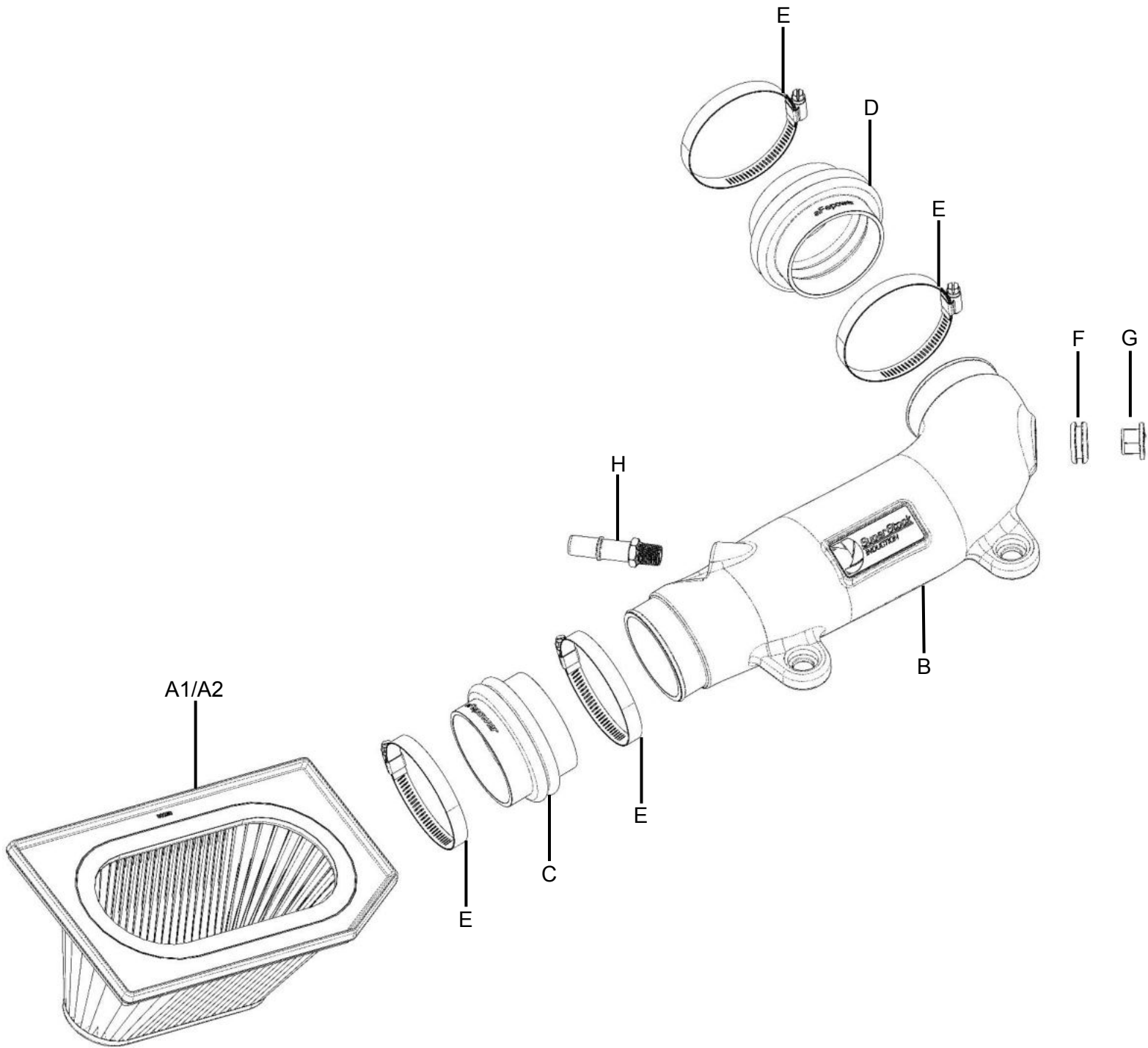

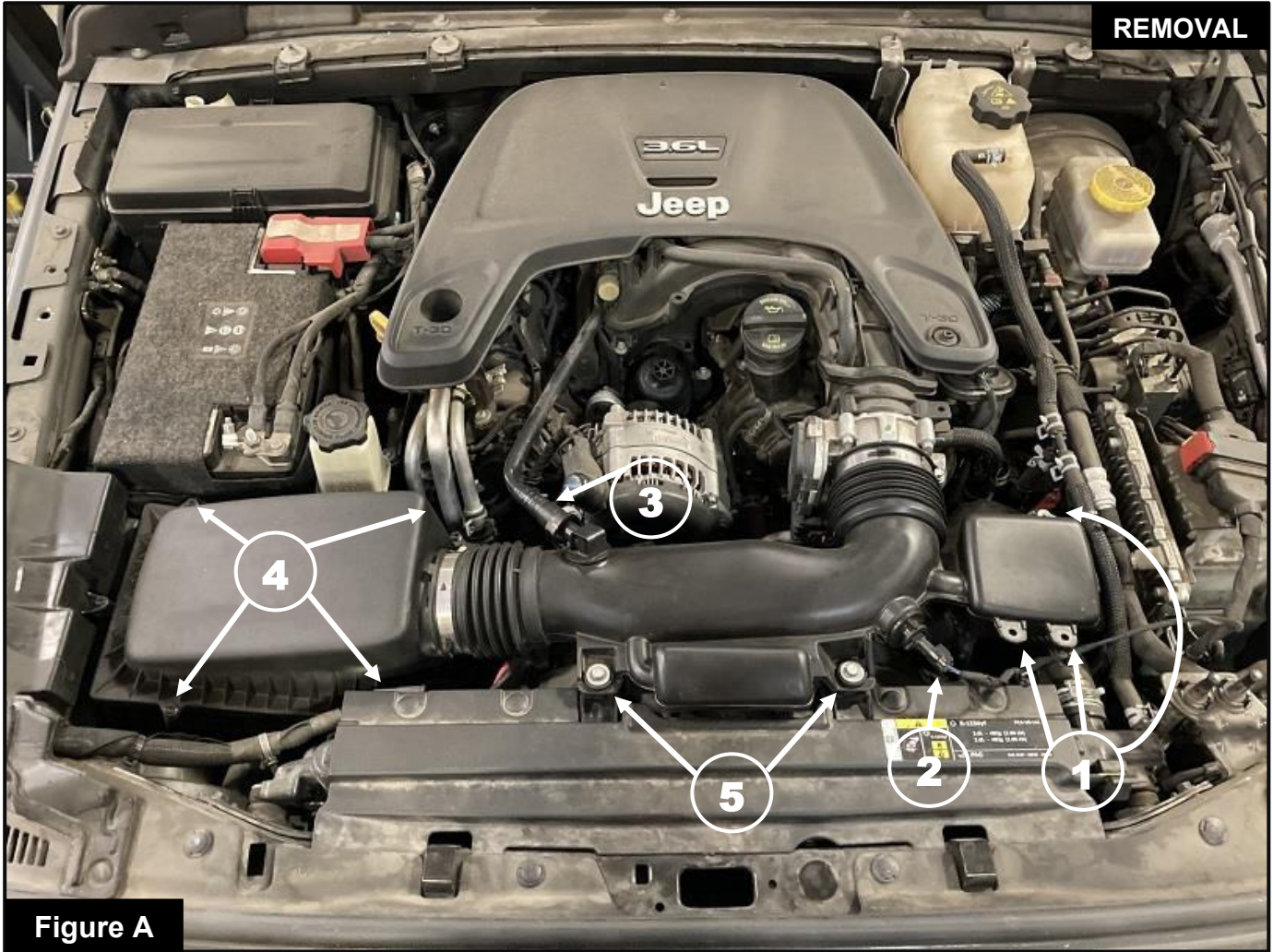
Figure A

Refer to Figure A for Steps 1-7

Step 1: Using a panel popper tool, release the three Christmas tree ties ① that connect to the intake tube.

Step 2: Disconnect the Intake Air Temperature (IAT) sensor plug ② be careful not to damage the sensor.

Step 3: Disconnect the Crank Case Vent (CCV) quick connect fitting ③ on top of the intake tube.

Step 4: Using an 8mm nut driver or socket, remove the four screws ④ in the upper air box.

Step 5: Using a 10mm socket, remove the two screws ⑤ holding the intake tube to the radiator shroud.

Step 6: Using an 8mm nut driver, loosen the two hose clamps at both ends of the intake tube.

Step 7: Remove the factory intake tube and upper half of the air box.



Figure B

Refer to Figure B for Steps 8-9

Step 8: Remove the factory air filter and install the aFe POWER air filter.

Note:

Be careful when installing not to crimp the edges of the aFe POWER air filter between the factory upper and lower housing. This could cause air filter damage and allow unfiltered air to enter the engine if not properly seated.

Step 9: Reinstall the upper air box using the factory screws and 8mm nut driver, from step 4.



Figure C

Refer to Figure C for Steps 10-11

Step 10: Install the vent tube fitting (6) in the location shown on the aFe POWER intake tube and tighten using an adjustable wrench.

***NOTE:** Exposed threads shown are normal. This is an NPT thread.

Step 11: Install the supplied grommet and plastic temp sensor bung (7) into the aFe POWER intake tube. If needed, use a light penetrating oil to help push the plastic bung into the grommet.



Refer to Figure D for Steps 12-13

Step 12: Remove the two factory grommets and spacers (8) from the OE intake tube. If needed, use a light penetrating oil to remove the spacer from the grommet.

Step 13: Install the two factory grommets and spacers (9) into the aFe POWER intake tube. Make sure the spacers are orientated the same way as in the factory tube.

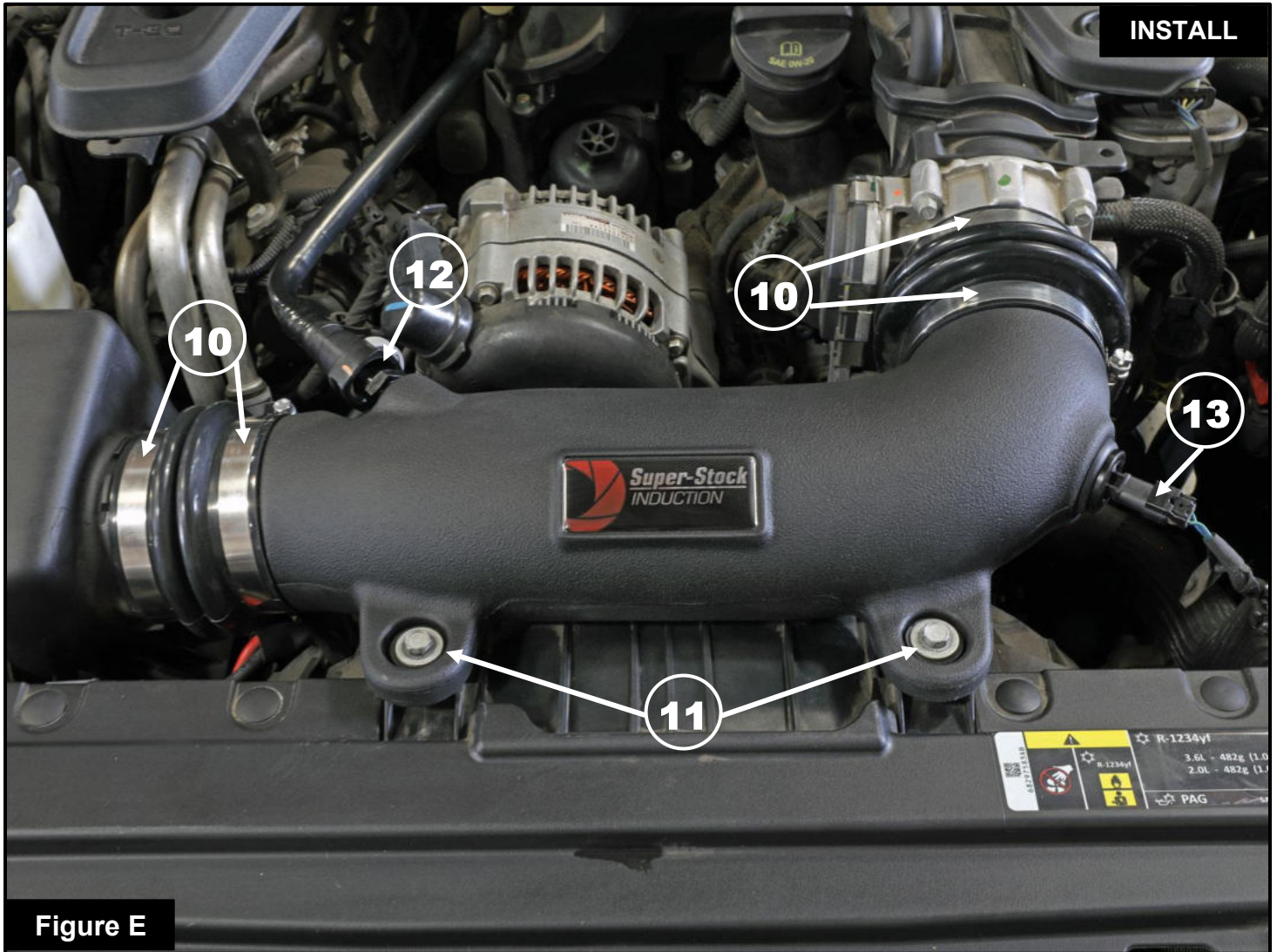

Figure E

Refer to Figure E for Steps 14-20

Step 14: Install the two supplied couplers onto the aFe POWER intake tube. The shorter coupler attaches on the air box side and the longer coupler attaches to the throttle body side.

Step 15: Install the aFe POWER intake tube with attached couplers onto the air box and the throttle body.

Step 16: Install and tighten the supplied hose clamps (10) onto the two couplers as shown.

Step 17: Install the two screws (11) into the aFe POWER intake tube, from step 5.

Step 18: Reconnect the CCV quick connect (12) on the the aFe POWER intake tube.

Step 19: Remove the IAT sensor from the factory intake tube and install it into the aFe POWER intake tube, then reconnect the electrical connector (13) to the sensor.

Step 20: Your installation is now complete. Thank you for choosing aFe POWER.

NOTE: Check all bolts, clamps, and connectors after 100-200 miles.



Page Left Blank Intentionally



Page Left Blank Intentionally



Page Left Blank Intentionally



advanced FLOW engineering, inc.

252 Granite Street Corona, CA 92879
TEL: 951.493.7100 • TECH: 951.493.7134
E-Mail: Tech@aFepower.com

06-81426