

advanced FLOW engineering

Cold Air Intake System

Instruction Manual P/N: 56-70005D / 56-70005R



Make: Hyundai	Model: Elantra	Year: 2017-2020	Engine: L4-1.6L Turbo
Make: Hyundai	Model: Elantra GT Sport	Year: 2018-2020	Engine: L4-1.6L Turbo
Make: Hyundai	Model: i30	Year: 2017-2022	Engine: L4-1.6L Turbo
Make: Hyundai	Model: Veloster	Year: 2019-2021	Engine: L4-1.6L Turbo
Make: Kia	Model: Forte GT	Year: 2019-2022	Engine: L4-1.6L Turbo
Make: Kia	Model: ProCeed GT	Year: 2019-2022	Engine: L4-1.6L Turbo



- Please read the entire instruction manual before proceeding.
- Ensure all components listed are present.
- If you are missing any of the components, call customer support at 951-493-7185.
- Ensure you have all necessary tools before proceeding.
- Do not attempt to work on your vehicle when the engine is hot.
- Retain factory parts for future use.

Retain factory parts for future use.

Label	Qty.	Description	Part Number
A1	1	Air Filter (Pro DRY S)	21-91108 (Grey Media)
A2	1	Air Filter (Pro 5R)	24-91108 (Blue Media)
B	1	Tube	05-5610005B1
C	1	Housing	05-5670005B2
D	1	Coupling, Silicone Reducer	05-01490
E	1	Clamp, #044	03-50019
F	2	Retainer Clips	03-50616
G	1	Clamp, #048	03-50007
H	1	Fitting, aluminum	03-50615
J	1	Plug, Silicone	05-01527

Installation will require the following tools:

8mm and 10mm socket, extension, ratchet, 16mm wrench, pliers and flat-head screwdriver.

Warranty Information available at: <https://afepower.com/contact#warranty>

Emissions Disclaimer:

This product is not currently CARB exempt and is not available for purchase in California or for use on any vehicle registered with the California Department of Motor Vehicles.

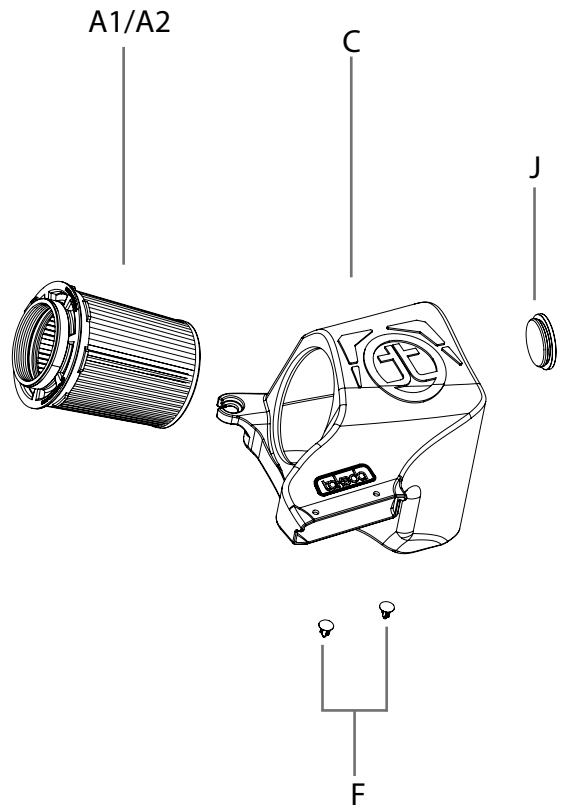
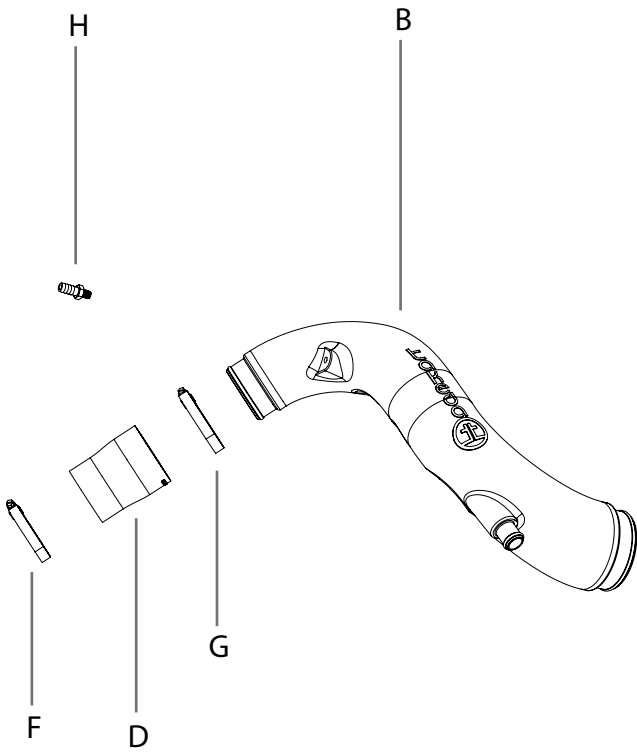



REMOVAL

FigureA

Refer to Figure A for Steps 1-3

Step 1: Remove the engine cover by pulling upward on it.

Step 2: Using pliers, open the clamp securing the hose to the air intake tube, and then slide the clamp away from the intake tube. This clamp will be re-used. Disconnect the rubber hose from the air intake tube.

Step 3: Release the two clips securing the top of the airbox to the bottom of the airbox.



FigureB

Refer to Figure B for Steps 4-5

Step 4: Using pliers, open the clamp securing the small hose to the air intake tube toward the firewall.

Slide the clamp away from the tube and disconnect the small rubber hose from the intake tube.

The clamp will be re-used.

Step 5: Loosen the clamp at the turbo inlet using a 10mm socket and ratchet.



Figure C

Refer to Figure C for Step 6

Step 6: Remove the top of the factory airbox and the tube as one piece from of the vehicle.

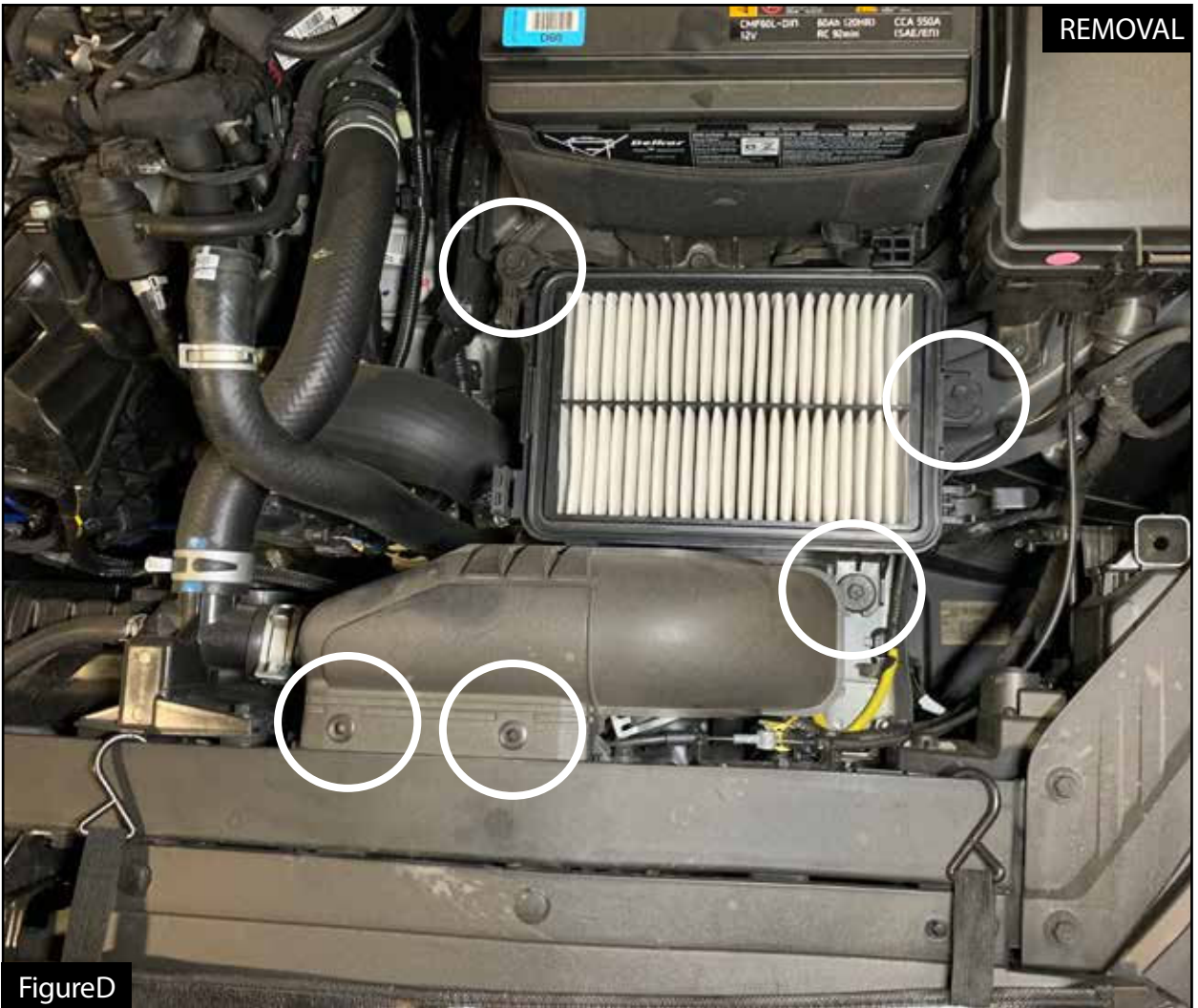

Refer to Figure D for Steps 7-9

Step 7: Remove the two plastic rivets connecting the factory air inlet to the front of the car. Use a flat-head screwdriver to press down on the center of the rivet to unlock, and then pull them out. These plastic rivets will be replaced.

Step 8: With a 10mm socket, extension and ratchet, loosen the three bolts securing the factory housing to the vehicle. These three bolts will be re-used during the installation of the Takeda air intake system.

Step 9: Remove the bottom of the factory housing and air inlet as one piece out of the vehicle.



FigureE

Refer to Figure E for Step 10

Step 10: Transfer the three mounting grommets and sleeves from the bottom of the factory housing to the Takeda housing.



Figure F

Refer to Figure F for Step 11

Step 11: The kit includes an optional plug to close off the side auxiliary air inlet. Install the plug if you wish to close off the side auxiliary air inlet and only capture cold air from the front.

- Without the plug installed, the Takeda intake will capture the maximum air available. More airflow offers more power. Yet some of this air is picked up from inside the engine compartment and could be warmer air. Warmer air will affect the performance of the vehicle.
- The plug installed on the housing will block off any hot engine air entering the housing and make sure the coolest air available is directed into the engine. It will also reduce the noise of the intake.



Figure G

Refer to Figure G for Steps 11-12

Step 11: Install the Takeda housing into the vehicle. Secure it with the three bolts removed at Step 7.

One of the bolts will be installed inside the housing.

Step 12: Secure the housing to the air inlet with the two provided christmas tree plastic rivets.



FigureH

Refer to Figure H for Step 13

Step 13: Install the air filter into the housing by firmly pushing it into the housing until the filter tabs lock it into place. Install on the clamp on the filter but do not tighten at this time.



Figure I

Refer to Figure I for Step 14

Step 14: Using a 16mm wrench, install the aluminum fitting into the Takeda air intake tube.

Note: This is an NPT fitting, the small gap between the 16mm hex and the tube is normal.



Figure J

Refer to Figure J for Step 15

Step 15: Install the coupling onto the turbo inlet (the smaller end of the coupling goes onto the turbo inlet). Install the provided clamps over the coupling, but do not tighten yet.



Figure K

Refer to Figure K for Steps 16-17

Step 16: Install the Takeda intake tube by sliding it into the coupling then into the air filter.

Step 17: Align the tube, filter and coupling then tighten all clamps.

INSTALL



Figure L

Refer to Figure L for Step 18

Step 18: Connect the small rubber hose to the aluminum fitting on the tube. Secure it with the factory pry clamp.



Figure M

Refer to Figure M for Steps 19-20

Step 19: Connect the bigger rubber hose to the Takeda air intake tube. Secure it with the factory pry clamp.

Step 20: Reinstall the engine cover.



Figure N

30.65108

Refer to Figure N for Step 21

Step 21: Make sure all clamps and connections are secured. Your installation is now complete. Thank you for choosing Takeda USA!

NOTE: Check all bolts, clamps and connectors after 100-200 miles.



PAGE LEFT BLANK INTENTIONALLY

PAGE LEFT BLANK INTENTIONALLY



advanced FLOW engineering, inc.
252 Granite Street Corona, CA 92879
<https://afepower.com/contact>