

advanced FLOW engineering

Takeda Momentum Cold Air Intake System

Instruction Manual P/N: 56-70014D / 56-70014R

Make: Subaru

Model: WRX STI

Year: 2018-2020

Engine: H4-2.5L(t)



- Please read the entire instruction manual before proceeding.
- Ensure all components listed are present.
- If you are missing any of the components, call customer support at 951-493-7185.
- Ensure you have all necessary tools before proceeding.
- Do not attempt to work on your vehicle when the engine is hot.
- Retain all factory parts for future use.

Label	Qty.	Description	Part Number
A1	1	Air Filter (Pro 5R)	24-91103
A2	1	Air Filter (Pro DRY S)	21-91103
B	1	Tube	05-5670014B1
C	1	Housing	05-5670014B2
D	1	Air Scoop	05-5670014B3
E	1	Coupling, Silicone Straight: 2-3/4"ID x 1-3/4"L	05-01107
F	2	Clamp, 044 (2-5/16" – 3-1/4")	03-50019
G	1	Harness, MAF Extension	05-01359
H	1	Plug, Silicone 2.25" Dia.	05-01527
I	2	Screw, Torx: M4	03-50490

Installation will require the following tools:

T20 Torx Driver, 8mm Nut Driver, 10mm Nut Driver, 10mm socket, Flat Head Screwdriver, Socket Wrench and Panel Clip Removal Tool.

Warranty Information available at <https://afepower.com/contact#warranty>

Emissions Disclaimer: This product is not currently CARB exempt and is not available for purchase in California or for use on any vehicle registered with the California Department of Motor Vehicles.

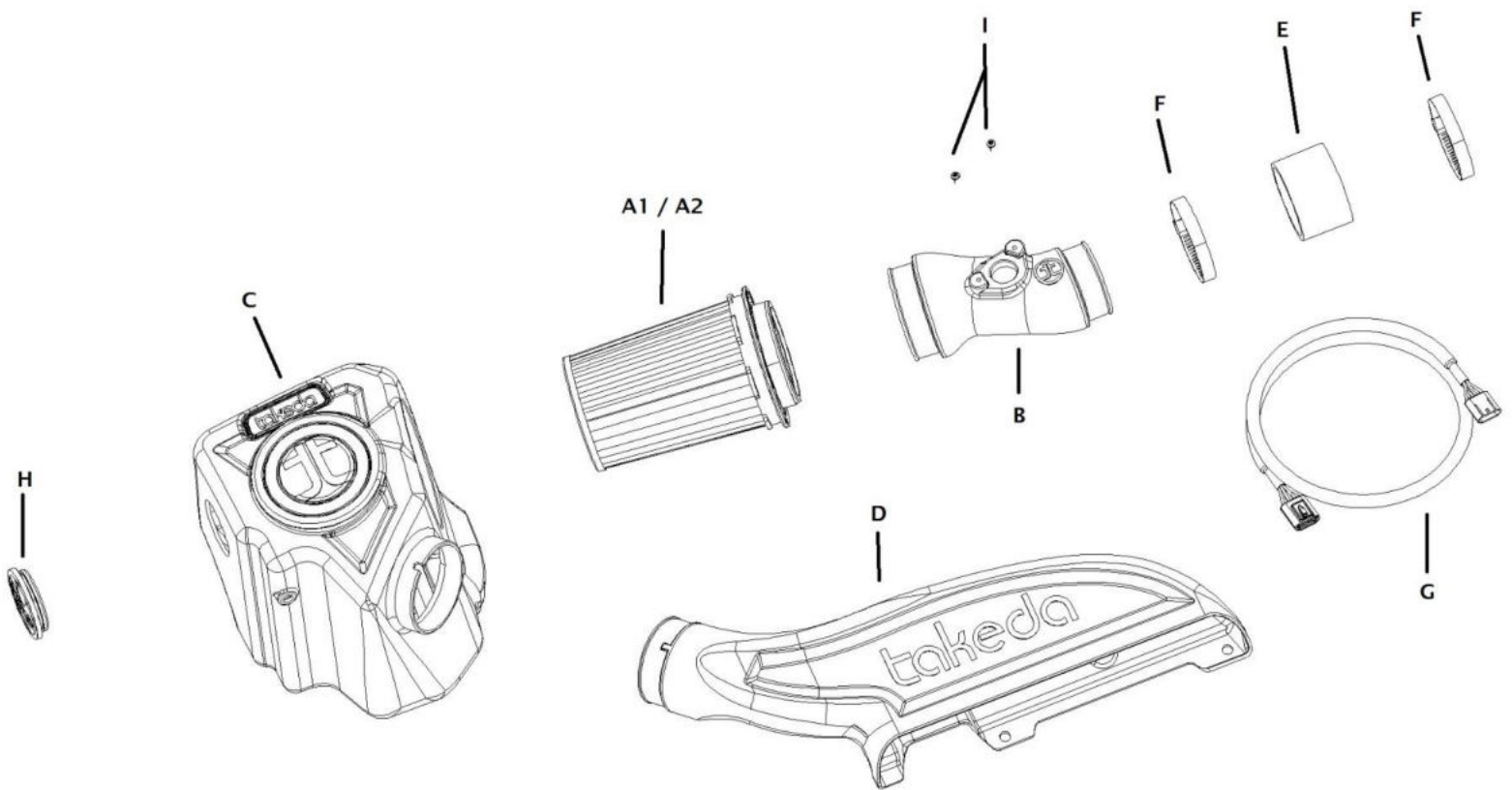

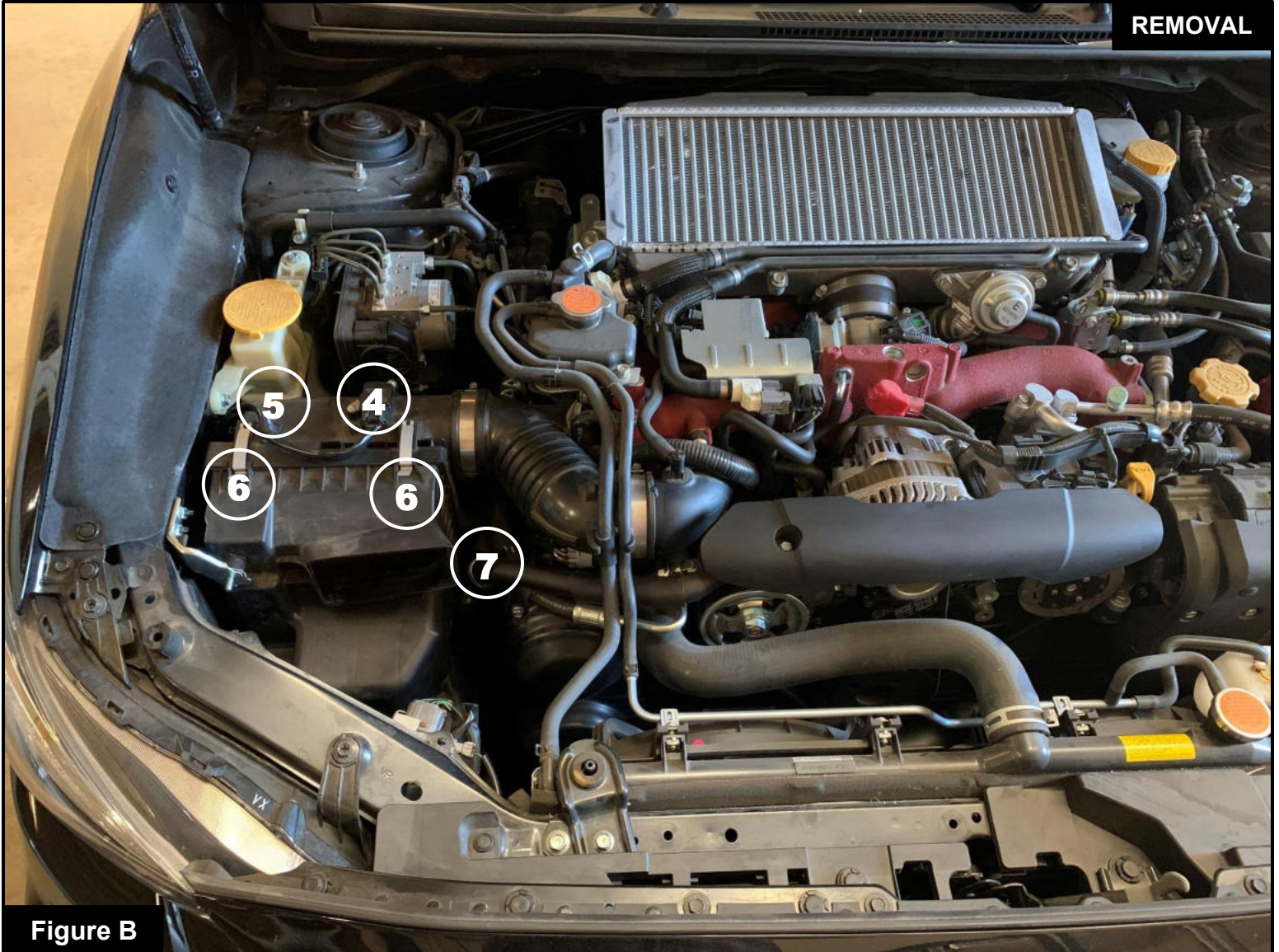

Figure A

Refer to Figure A for Steps 1-3

Step 1: With an 8mm nut driver, loosen the two clamps ① on the factory intake tube.

Step 2: Use a flathead screwdriver to remove the two clips ② holding the stock air scoop onto the vehicle and set aside for later use. Remove the scoop by pulling it directly upwards.

Step 3: Using a 10mm socket and ratcheting wrench, remove the M6 nut ③ holding the factory housing to the metal fender bracket and set aside for later use.

Figure B
Refer to Figure B for Steps 4-7

Step 4: Locate the MAF sensor (4). Disconnect the harness from the sensor and use a panel clip removal tool to remove the harness clip (5) from the factory housing.

Step 5: Unclip the two tabs (6) on the top of the factory housing.

Step 6: Remove factory intake tube from the vehicle.

Step 7: Unclip the vacuum line (7) and then remove the back half of the factory housing from the vehicle.

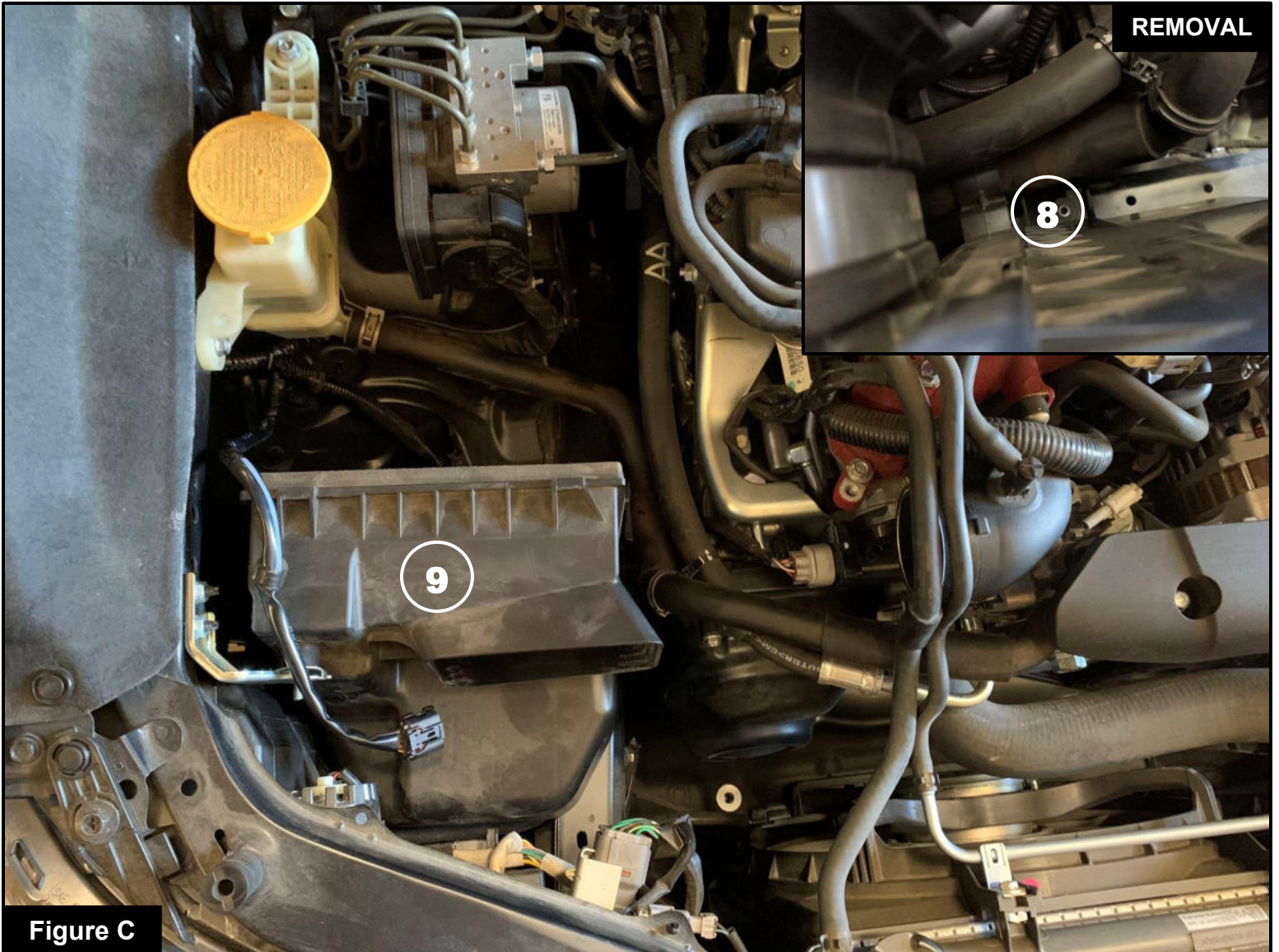

Figure C

Refer to Figure C for Steps 8-9

Step 8: Using a 10mm nut driver, remove the M6 screw (8) securing the airbox and set aside for later use.

Step 9: Remove the front of the factory housing (9) from the vehicle.

**Figure D****Refer to Figure D for Step 10**

Step 10: Remove the grommet and metal sleeve ⑩ from the factory housing and transfer both over to the Takeda housing.



Figure E

Refer to Figure E for Steps 11-12

Step 11: Using a 10mm nut driver, remove the M6 nut (11) attaching the damping mount (12) to the factory housing.

Step 12: Transfer the M6 nut (11) and the damping mount (12) to the Takeda housing.

At this time, use the provided silicone plug to close the additional air inlet if desired.

Best performance gain is obtained by having more air flow (no plug).



Figure F

Refer to Figure F for Step 13

Step 13: Install the Takeda housing into the vehicle and secure using the M6 screw (13) removed in Step 7 as well as the M6 nut (14) removed in Step 3.

**Figure G****Refer to Figure G for Steps 14-15**

Step 14: Using a T20 torx driver, remove the 2 screws (15) holding the MAF into the factory housing.

Step 15: Install the MAF into the Takeda intake tube using the 2 supplied M4 screws (16).

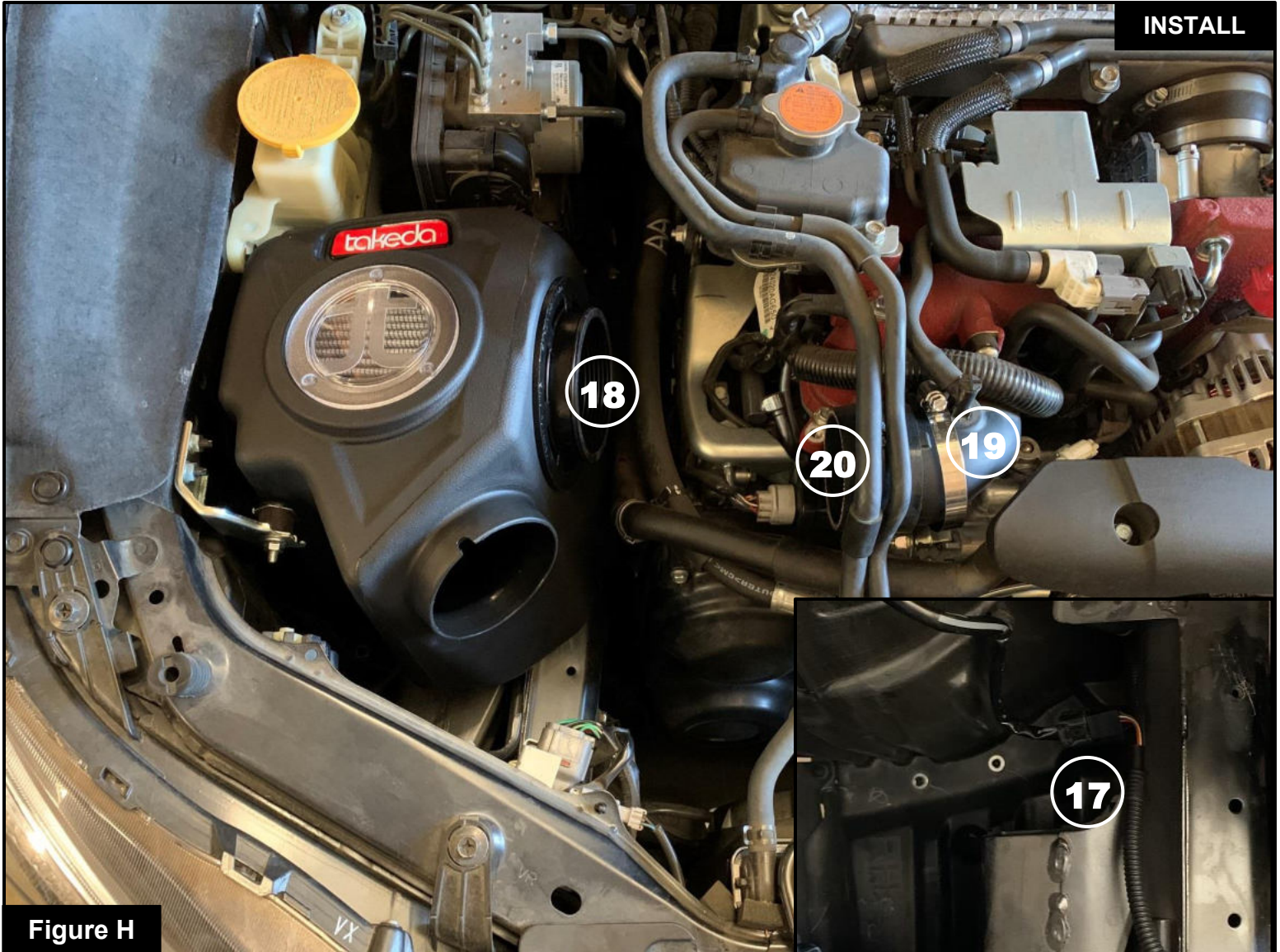

Figure H

Refer to Figure H for Steps 16-18

Step 16: **FOR 2019+ MODELS ONLY:** Install the MAF harness extension (17) and route along frame as shown.

Step 17: Install the aFe Power air filter (18) into the Takeda housing, removing the clamp for later use.

Step 18: Slip the supplied #044 clamp (19) and coupling (20) over the turbo inlet tube and tighten the clamp using an 8mm nut driver.



Figure I

Refer to Figure I for Step 19

Step 19: Install the other #044 clamp (21) over the smaller end of the Takeda intake tube (22). Now install the Takeda intake tube into the vehicle, slip the larger end of the tube into the filter and smaller end of the tube into the coupling. Tighten the #044 clamp using an 8mm nut driver.

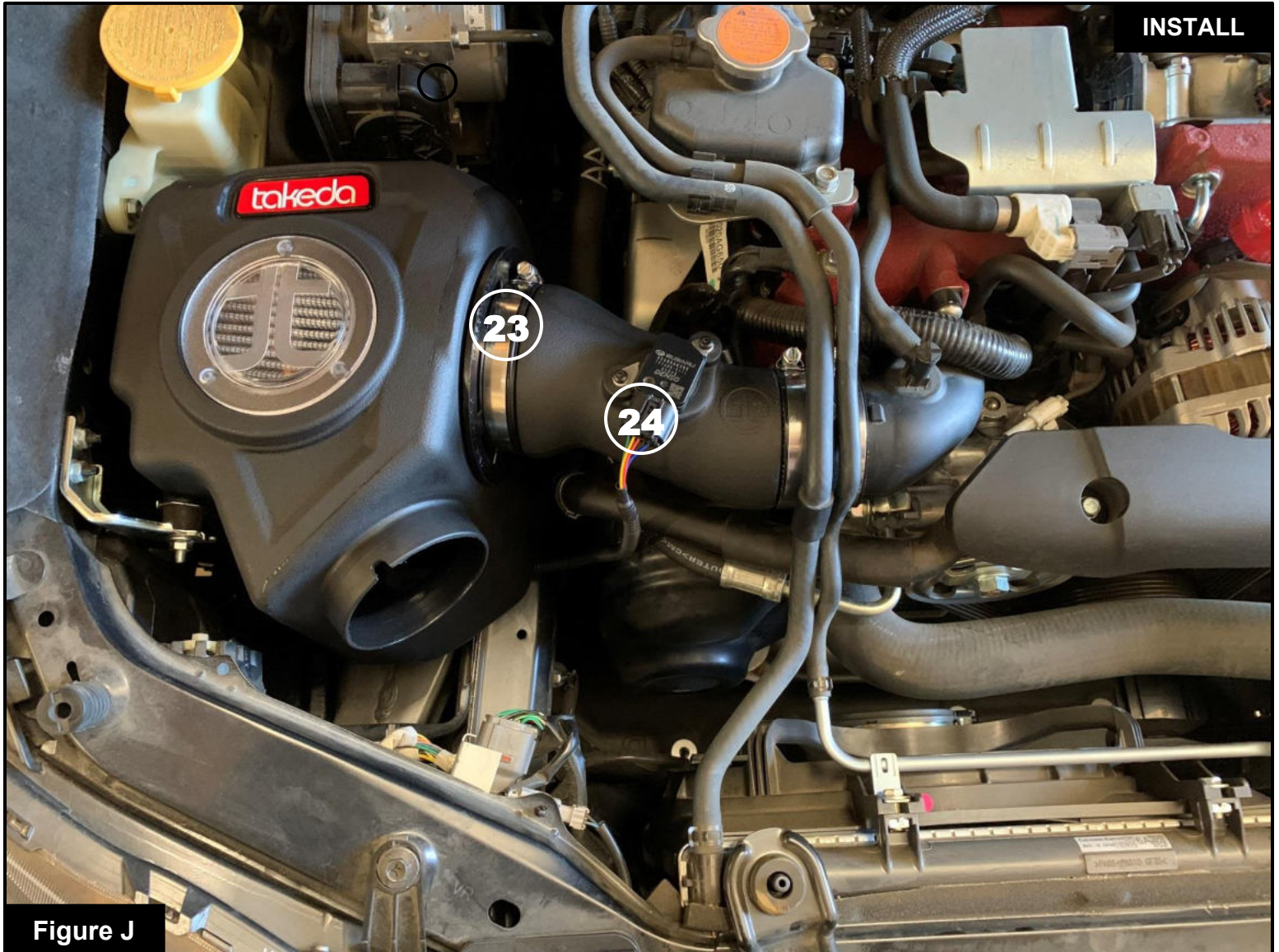

Refer to Figure J for Steps 20-21

Step 20: Install the supplied filter clamp (23) onto the air filter and tighten using an 8mm nut driver

Step 21: Re-connect the MAF sensor (24), ensure the harness clips connect properly.



Figure K

Refer to Figure K for Step 22

Step 22: Install the Takeda Air Scoop (25) using the two clips (26) removed in Step 2.

**Figure L****Refer to Figure L for Step 23**

Step 23: Check that all components are tight and secure. Your installation is now complete. Thank you for choosing aFe Power!

NOTE: Check all bolts, clamps, and connectors after 100-200 miles.



advanced FLOW engineering, inc.

252 Granite Street Corona, CA 92879

<https://afepower.com/contact>