

advanced FLOW engineering

Instruction Manual P/N: TM-1016B-1 & TM-1016B-D



Make: **Honda** Model: **CR-Z** Year: **2011-2016** Engine: **L4-1.5L**



- Please read the entire instruction manual before proceeding.
- Ensure all components listed are present.
- If you are missing any of the components, call customer support at 951-493-7100.
- Ensure you have all necessary tools before proceeding.
- Do not attempt to work on your vehicle when the engine is hot.
- Disconnect the negative battery terminal before proceeding.
- Retain factory parts for future use.

Label	Qty.	Description	Part Number
A-1	1	Air Filter (Pro DRY S)	TF-9019D (Grey Media) TM-1016B-D
A-2	1	Air Filter (Pro 5R)	TF-9019R (Blue Media) TM-1016B-1
B	1	Tube (Wrinkle Black)	05-T1016B3
C	1	Housing	05-T1016B2
D	1	Coupling: 2-1/2" ID x 2"L	05-01188
E	2	Clamp, 044	03-50019
F	1	Hose, 3/8" (10 inches)	05-00110
G	2	Screw, Btn Hd: M8	03-50258
H	2	Nut, Hex Nylon Lock: M8	03-50244
I	1	Clamp, 096	03-50003
J	1	Grommet	03-50076
K	1	Fitting, Elbow	03-50151
L	1	Gasket, Maf Sensor	05-00631

Installation will require the following tools:

Phillips screw driver, 10mm socket, Extension, Ratchet, Pliers & 5/16 nut driver.

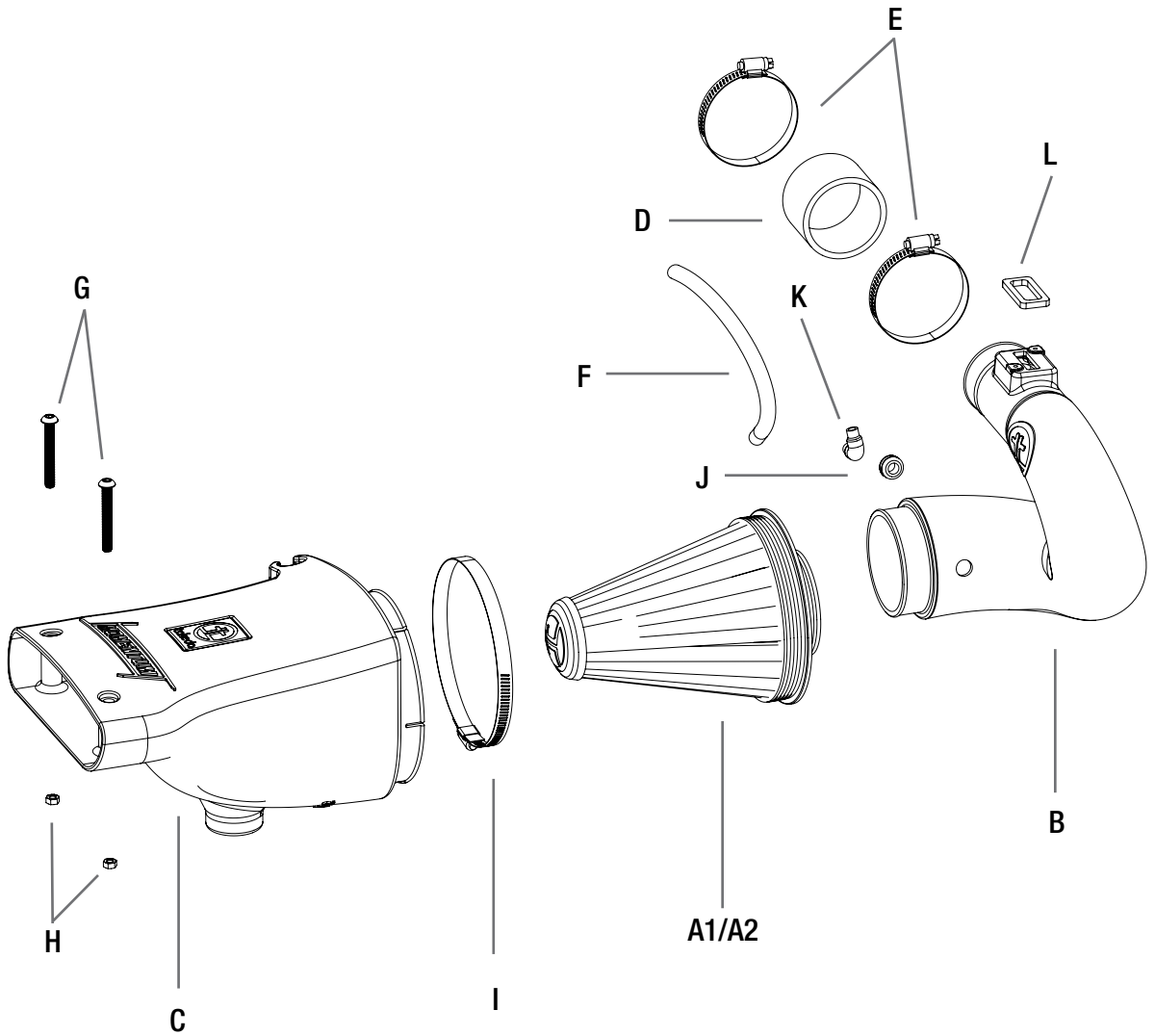

**Figure A****Refer to Figure A for step 1**

Step 1: Disconnect MAF sensor (1) and harness clip that holds it to the top air box.



Refer to Figure B for steps 2-6

Step 2: Loosen factory clamp at the throttle body ② with a phillips screw driver.

Step 3: Disconnect the crank case vent line from the top airbox ③ with pliers.

Step 4: Unscrew factory airbox ④ from its two mounting locations.

Step 5: Remove the two push clips from the front snorkel ⑤ .

Step 6: Disconnect the lower resonance tube ⑥ from the snorkel and pull the entire intake system out of the vehicle.



Figure C

Refer to Figure C for steps 7-9

- Step 7: Install the mass air flow sensor from the original intake system onto the Takeda intake tube using furnished gasket and screws.
- Step 8: Install the coupling onto the Takeda intake tube with the clamps provided.
(Do not tighten at this time)
- Step 9: Install furnished grommet and 90 degree fitting into the hole on the intake tube.



Figure D

Refer to Figure D for steps 10-11

- Step 10: Remove factory grommet from the factory airbox and install it onto the Takeda housing (7).
- Step 11: Slide your takeda air filter into your takeda air box and tighten the clamp on the outside of the housing to secure it.

Figure E

Refer to Figure E for steps 12-17

Step 12: Install the Takeda intake tube onto the throttle body

Step 13: Connect the resonance tube to the bottom of the Takeda air box and place into the vehicle.

Step 14: Insert the Takeda intake tube into the filter.

Step 15: Mount your air box using one of the factory bolts and grommet removed in step 5 (8).

Step 16: Using the bolts, screws, and supplied, mount the front of the airbox to the vehicle (9) using the factory snorkels mounting locations.

Step 17: Tighten all clamps



Figure F

Refer to Figure F for steps 18-19

Step 18: Install the supplied vacuum hose onto the Takeda intake tube fitting and connect it to the crankcase vent line removed in step 4 (10).

Step 19: Reconnect battery cable. Your installation is now complete. Verify all clamps are secure and re-check periodically.

NOTE: Retighten all connections after approximately 100-200 miles.

Place enclosed CARB EO sticker on or near the device on a smooth, clean surface.

EO identification label is required to pass the smog inspection.

Pro DRY S Air Filter



P/N: TF-9019D

Pro 5R Air Filter



P/N: TF-9019R

Pro DRY S Restore Kit



P/N: TP-7015C

Takeda Tee



P/N: TP-7004T M
P/N: TP-7005T L
P/N: TP-7006T XL
P/N: TP-7007T 2XL

Key Chain



P/N: TP-7018K

Key Chain



P/N: TP-7024K

Mascot Decal



P/N: TP-7003D

Lic. Plate Frame



P/N: TP-7014F

To purchase any of the items above, view airflow charts, dyno graphs, photos, and video; please go to aFepower.com.

Warranty

General Terms:

- aFe warrants their products to be free from manufacturer's defects due to workmanship and material.
- This warranty applies only to the original purchaser of the product and is non-transferrable.
- Proof of purchase of the aFe product is required for all warranty claims.
- Warranty is valid provided aFe instructions for installation and/or cleaning were properly followed.
- Proper maintenance with regular inspections of product is required to insure warranty coverage.
- Damage due to improper installation, abuse, unauthorized repair or alteration is not warranted.
- Incidental or consequential damages or cost, including installation and removal of part, incurred due to failure of aFe product is not covered under this warranty.
- All warranty is limited to the repair and/or replacement of the aFe part. To request Return Goods Authorization ("RGA"), email RGA@afepower.com or call (951)493-7100. Upon receipt of the RGA, you must return the product to the address provided in the RGA, freight prepaid and accompanied with a dated proof of purchase and the RGA. Upon receipt of the defective product and upon verification of proof of purchase, aFe will either repair or replace the defective product within a reasonable time, not to exceed thirty days.

Product Category	P/N Prefix	Warranty duration
Direct OE Replacement Filters	10, 11, 30, 31, 71, 73	Life of the vehicle
Racing Filters	18	1 year
Universal	21, 24, 72, TF	2 years
Air Intake Systems	50, 51, 54, 55, 75, TR, TA, TL	2 years
Exhaust Systems	49	2 years
Intercoolers & Intercooler Tubes	46-2	2 years
Intake Manifolds	46-1	2 years
Differential Cover	46-7	Life of the vehicle
Exhaust Manifolds	46	2 years
Throttle Body Spacers	46-3	2 years
Turbochargers	46-6	2 years*
Fluid Filters	44	90 days
Pre-Filters	28	2 years
Heavy Duty OE Replacement	70	2 years
PowerSports OE Replacement	81, 87	2 years
PowerSports Intake Systems	85	2 years

No other warranty expressed or implied applies nor is any person or advanced FLOW engineering authorized to assume any other warranty. Some States do not allow the exclusion or limitation of incidental or consequential damages or do not allow limitations on how long an implied warranty lasts, so the above limitations or exclusions may not apply to you. This warranty gives you specific legal rights, and you may also have other rights which vary from State to State.

*See turbocharger warranty for more info



advanced FLOW engineering, inc.

252 Granite Street Corona, CA 92879

TEL: 951.493.7100 • TECH: 951.493.7100 x23

E-Mail: Tech@aFepower.com