

advanced FLOW engineering Takeda Cold Air Intake System

**Instruction Manual** P/N: 56-70006D / 56-70006R

Make: **MAZDA** Model: **MX-5 MIATA** Year: **2016-2020** Engine: **L4-2.0L**



- Please read the entire instruction manual before proceeding.
- Ensure all components listed are present.
- If you are missing any of the components, call customer support at 951-493-7100.
- Ensure you have all necessary tools before proceeding.
- Do not attempt to work on your vehicle when the engine is hot.
- Disconnect the negative battery terminal before proceeding.

## Retain factory parts for future use.

Label	Qty.	Description	Part Number
A1	1	Air Filter (Pro DRY S)	21-91103
A2	1	Air Filter (Pro 5R)	24-91103
B	1	Tube	05-5670006B1
C	1	Housing	05-5670006B2
D	1	Coupling, Silicone Bellow	05-01497
E	1	Plug, for Housing	05-00937
F	2	Clamp #044	03-50019
G	1	Hose, Silicone: 3/8"ID (13")	05-01503
H	2	Screw, M4 x 10mm	03-50490
I	1	Torx Bit: T20	03-50066
J	1	Mount, Silicone	03-50534
K	1	Cap, Vinyl	03-50548
L	1	Fitting, Elbow	03-50151

### Installation will require the following tools:

Flat head and Phillips screwdriver, 8mm nut driver, 10mm nut driver, 10mm socket and socket wrench, Needle-Nose Pliers.

Note: Legal in California for use on race vehicles only. The use of this device on vehicles used on public streets or highways is strictly prohibited in California and others states that have adopted California emission regulations.

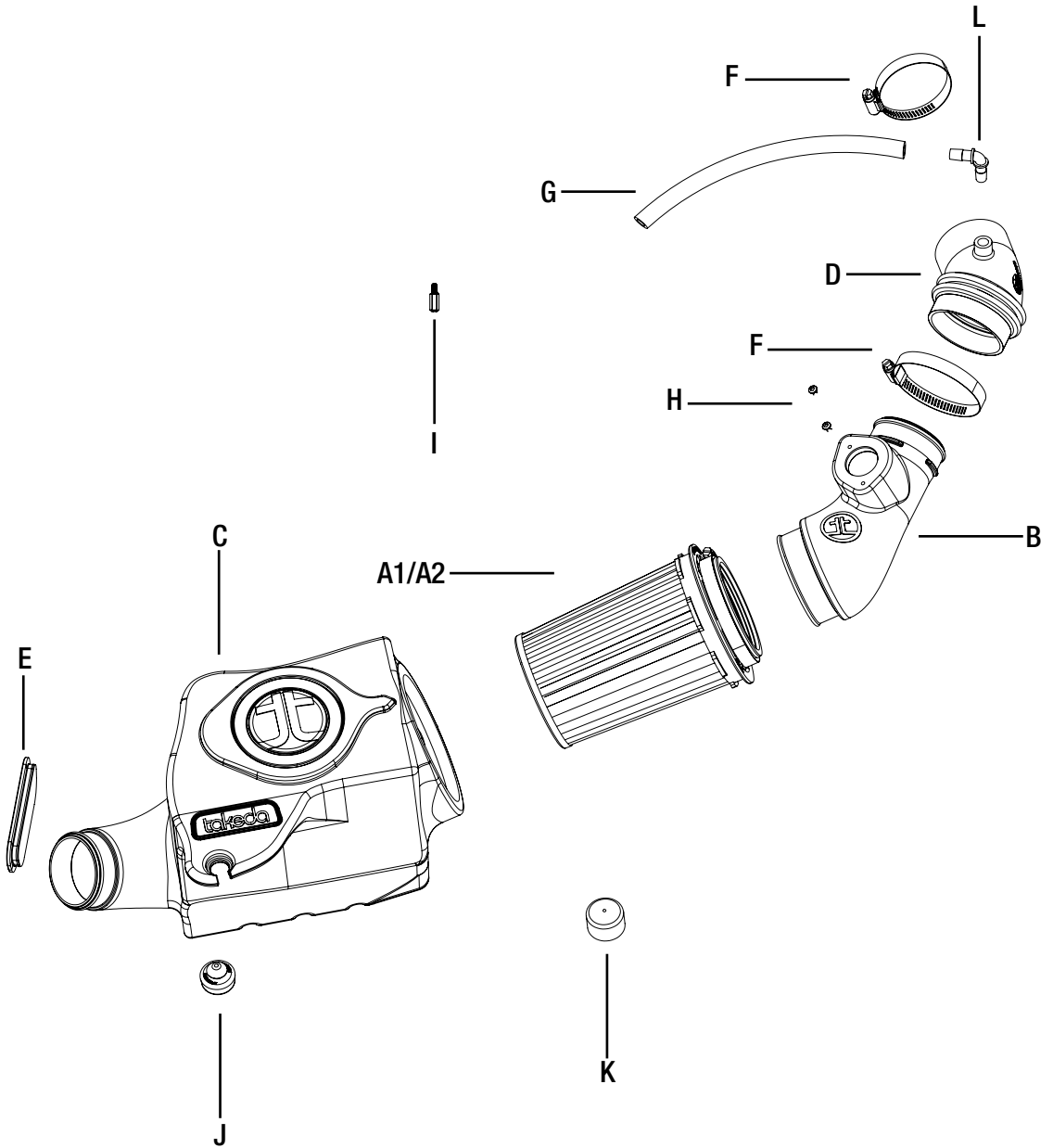

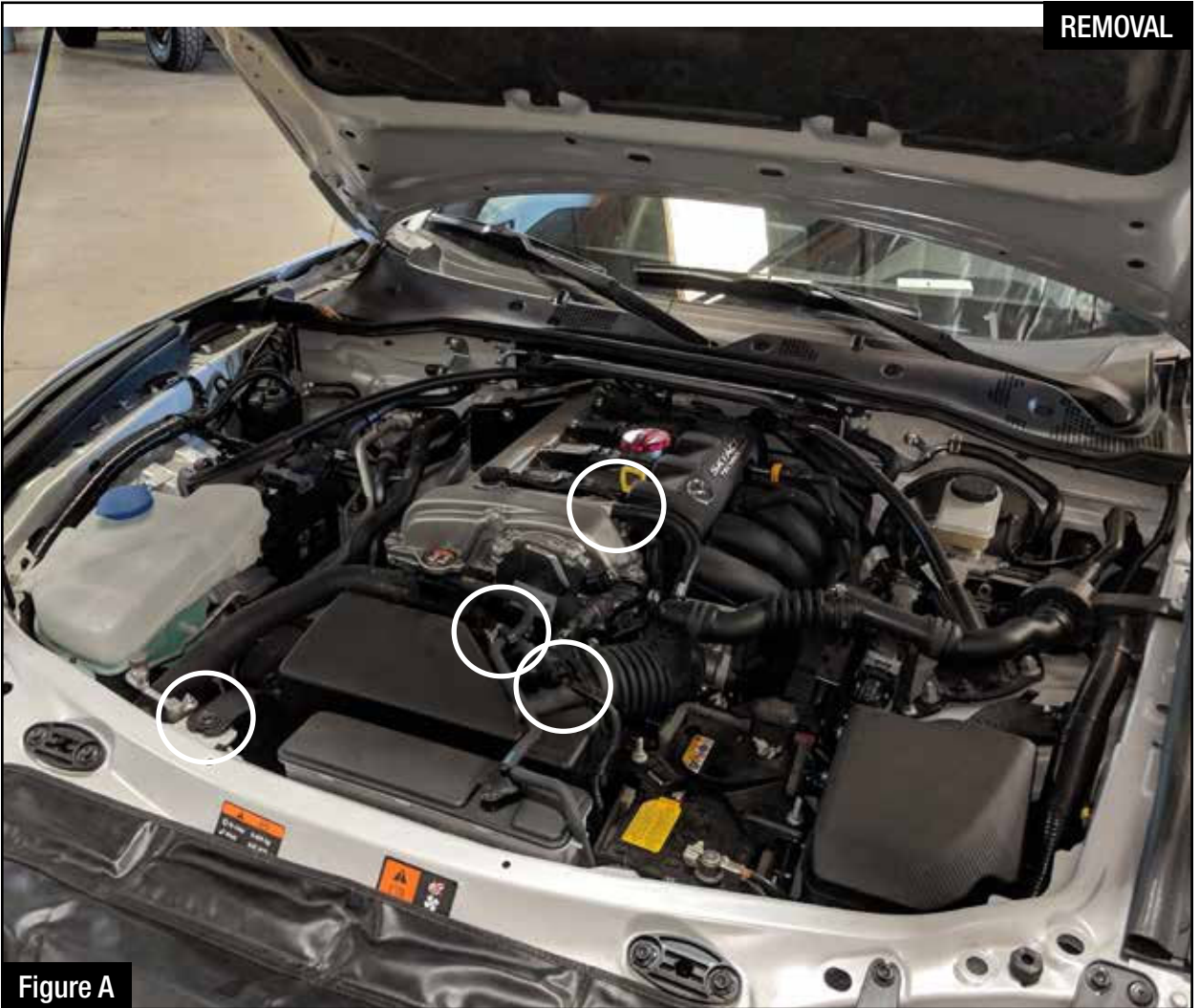
**Figure A****Refer to Figure A for Steps 1-5:**

Step 1: Disconnect the MAF harness.

Step 2: Remove the MAF harness clip from the airbox.

Step 3: Unclip the coolant reservoir line from the housing.

Step 4: Remove the 10mm bolt holding down the factory housing. Remove the bushing and metal collar from the factory housing. These 3 items will be re-used for installation.

Step 5: Disconnect the PCV hose from the valve cover fitting.

**Figure B****Refer to Figure B for Steps 6-7:**

Step 6: Loosen the two clamps securing the tube to the intake box and the throttle body.

Step 7: Release the top part of the housing by releasing the two clips holding it down and sliding it out.



**Refer to Figure C for Step 8-9:**

Step 8: Unclip the Sound tube assembly from the fitting leading to the firewall.

Step 9: Remove the intake coupling and sound tube assembly.

**Figure D****Refer to Figure D for Step 10-11:**

Step 10: Cover sound tube fitting opening with provided vinyl cap.

Step 11: Remove the bottom section of the housing by gently pulling it up from the vehicle.



Figure E

**Refer to Figure E for Steps 12-13:**

Step 12: Remove one of the rubber grommets from the bottom of the factory housing and transfer it to the bottom of the Takeda housing.

Step 13: Install the provided silicone mount into the bottom of the housing.



Figure F

**Refer to Figure F for Step 14-15:**

Step 14: Insert the rubber bushing and metal collar into the mount on top of the Takeda air box.

Step 15: Insert the air filter into the housing. Push it in until it locks into place.



Figure G

**Refer to Figure G for Steps 16-18:**

Step 16: Lower the housing into place, with the large grommet sliding over the post at the bottom of the engine bay.

Step 17: Secure the housing to the top mount using the 10mm screw.



Figure H

**Refer to Figure H for Steps 18-19:**

Step 18: Place the provided coupling and clamp onto the throttle body.

Step 19: Slide the other provided clamp onto the coupling and insert the intake tube into the coupling.

**Figure I****Refer to Figure I for Steps 20-25:**

Step 20: Insert the larger end of the intake tube into the air filter. Tighten down all 3 worm clamps on to secure the intake tube and coupling.

Step 21: Insert fitting into port on coupling.

Step 22: Insert one end of the provided silicone hose onto fitting on the coupling. Attach the other end onto the fitting located on the valve cover.

Step 23: Insert the MAF sensor into the tube and secure it using the provided M4 screws.

Step 24: Reconnect the MAF harness to the sensor.

Step 25: Your installation is now complete. Thank you for choosing aFePower.

Page left blank intentionally



Pro DRY S Air Filter



P/N: 21-91103

Pro 5R Air Filter



P/N: 24-91103

Pro DRY S Restore Kit



P/N: 90-59999

Blue Squeeze Restore Kit



P/N: 90-50501

SPRINT BOOSTER V3



P/N: 40-30441-B (S)  
40-30442-B (M)  
40-30443-B (L)  
40-30444-B (XL)  
40-30445-B (2XL)



P/N: 77-16901

# Warranty

## General Terms:

- aFe warrants their products to be free from manufacturer's defects due to workmanship and material.
- This warranty applies only to the original purchaser of the product and is nontransferable.
- Proof of purchase of the aFe product is required for all warranty claims.
- Warranty is valid provided aFe instructions for installation and/or cleaning were properly followed.
- Proper maintenance with regular inspections of product is required to insure warranty coverage.
- Damage due to improper installation, abuse, unauthorized repair or alteration is not warranted.
- Incidental or consequential damages or cost, including installation and removal of part, incurred due to failure of aFe product is not covered under this warranty.
- All warranty is limited to the repair and/or replacement of the aFe part. To request Return Goods Authorization ("RGA"), email [RGA@afepower.com](mailto:RGA@afepower.com) or call (951)493-7100. Upon receipt of the RGA, you must return the product to the address provided in the RGA, freight prepaid and accompanied with a dated proof of purchase and the RGA. Upon receipt of the defective product and upon verification of proof of purchase, aFe will either repair or replace the defective product within a reasonable time, not to exceed thirty days.

<b>Product Category</b>	<b>P/N Prefix</b>	<b>Warranty duration</b>
Direct OE Replacement Filters	10, 11, 30, 31, 71, 73	Life of the vehicle
Racing Filters	18	1 year
Universal	21, 24, 72	2 years
Air Intake Systems	50, 51, 54, 55, 56, 75	2 years
Exhaust Systems	49	2 years
Intercoolers & Intercooler Tubes	46-2	2 years
Intake Manifolds	46-1	2 years
Differential Cover	46-7	Life of the vehicle
Exhaust Manifolds	46	2 years
Throttle Body Spacers	46-3	2 years
Fluid Filters	44	90 days
Pre-Filters	28	2 years
Heavy Duty OE Replacement	70	2 years
PowerSports OE Replacement	81, 87	2 years
PowerSports Intake Systems	85	2 years

No other warranty expressed or implied applies nor is any person or advanced FLOW engineering authorized to assume any other warranty. Some States do not allow the exclusion or limitation of incidental or consequential damages or do not allow limitations on how long an implied warranty lasts, so the above limitations or exclusions may not apply to you. This warranty gives you specific legal rights, and you may also have other rights which vary from State to State.

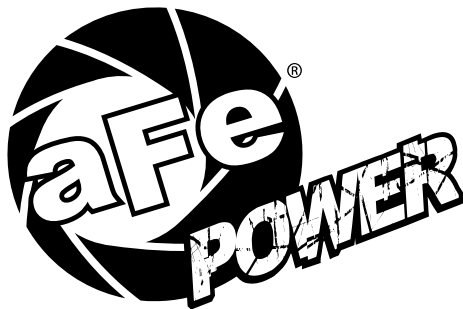

advanced FLOW engineering, inc.  
252 Granite Street Corona, CA 92879  
TEL: 951.493.7100 • TECH: 951.493.7134  
E-Mail: [Tech@aFepower.com](mailto:Tech@aFepower.com)