

advanced FLOW engineering Cold Air Intake System

Instruction Manual P/N: 56-70034D / 56-70034R

Make: Toyota

Model: Rav 4

Year: 2019-2022

Engine: L4-2.5L



- Please read the entire instruction manual before proceeding.
- Ensure all components listed are present.
- For technical support please call 951-493-7185.
- Ensure you have all necessary tools before proceeding.
- Do not attempt to work on your vehicle when the engine is hot.
- Retain factory parts for future use.

Label	Qty.	Description	Part Number
A1	1	Air Filter (Pro 5R)	24-91103
A2	1	Air Filter (Pro DRY S)	21-91103
B	1	Filter Housing	05-5670034B2
C	1	Intake Tube	05-5670034B1
D	1	Coupling, Silicone Reducer	05-01400
E	2	Clamp #048	03-50007
F	2	Screw, Torx: M4x10mm	03-50490
G	1	Hose Fitting, Barbed: 3/16" ID	03-50191
H	1	Silicone Plug, Takeda	05-01527
J	1	Hose, 5/8" ID (12"L)	05-01502

Installation will require the following tools:

8mm & 10mm nut drivers, 11mm deep socket and driver, T20 Torx driver, Hose Clam Pliers or Channel Locks, Needle Nosed Pliers, #1 Phillips Head Screwdriver

Warranty Information available at <https://afepower.com/contact#warranty>

Emissions Disclaimer: This product is not currently CARB exempt and is not available for purchase in California or for use on any vehicle registered with the California Department of Motor Vehicles.

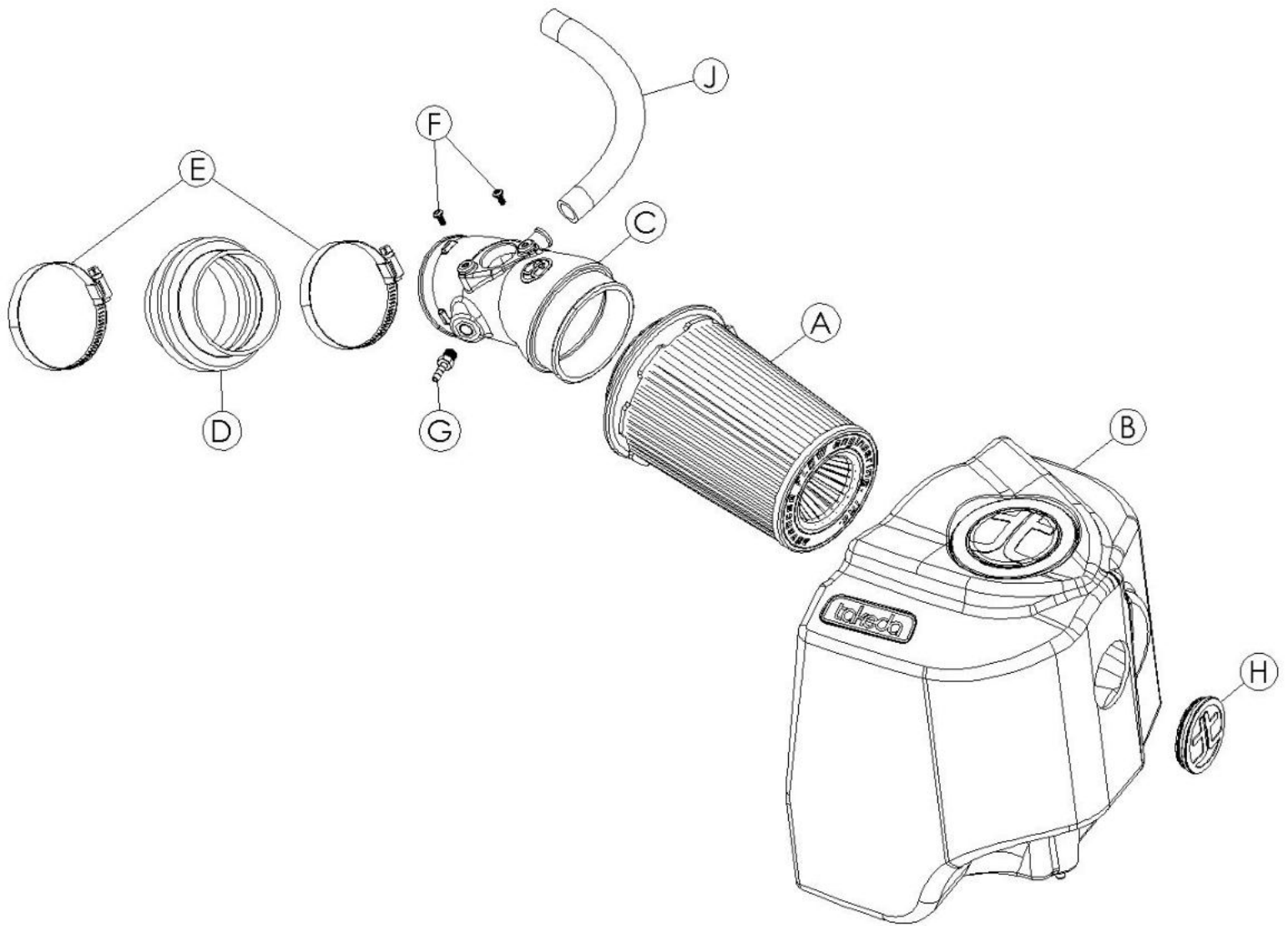



Figure A

Refer to Figure A for Step 1

Step 1: Remove the engine cover ①.

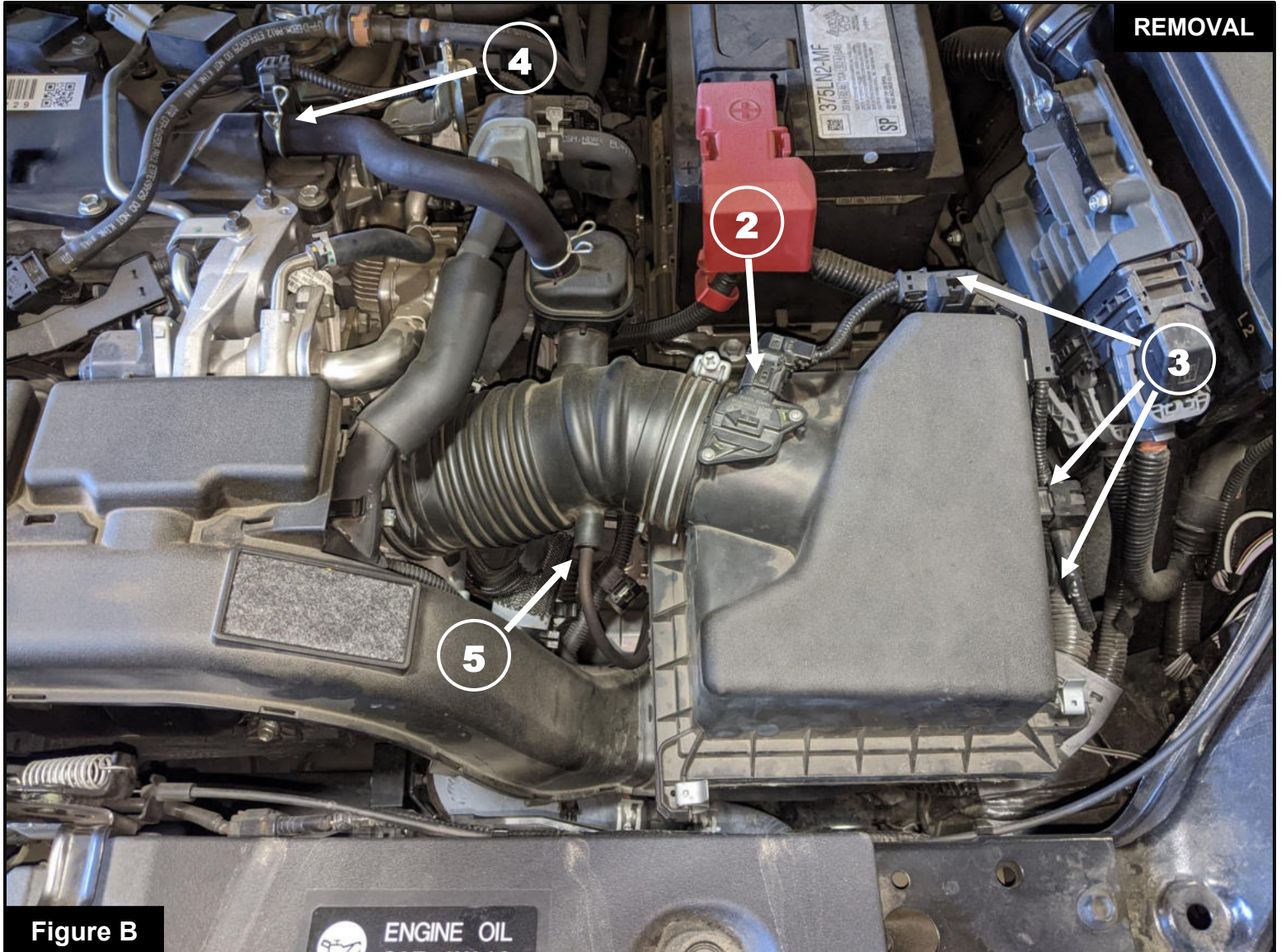

Figure B

Refer to Figure B for Steps 2-4

Step 2: Disconnect the Mass Airflow Sensor wire harness (2), then unclip the wire harness in all 3 locations (3). (The lowest clip requires use of needle nose pliers to remove without damaging the clip)

Step 3: Disconnect the valve cover vent line (4) from the port on the valve cover.

Step 4: Disconnect the CCV line (5) from the front side of the factory intake tube.

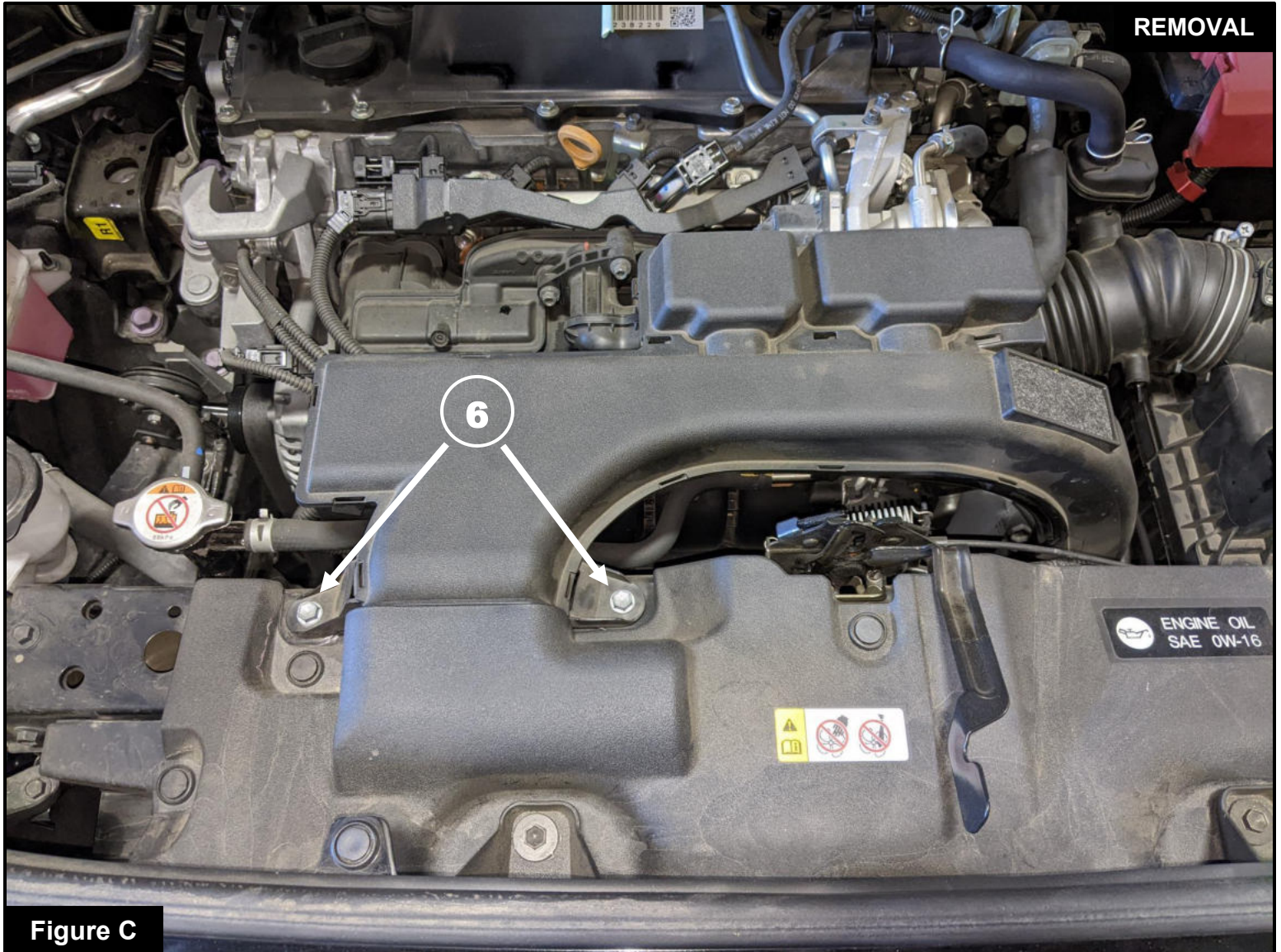

Figure C

Refer to Figure C for Step 5

Step 5: Using a 10mm nut driver, remove the two (2x) screws (6) securing the factory inlet scoop to the core support, then remove the scoop by pulling the base out of the factory airbox.



Figure D

Refer to Figure D for Steps 6-7

Step 6: Using a pair of hose clamp pliers or channel lock pliers, loosen the clamp on the factory intake tube at the throttle body ⑦ and disconnect the tube

Step 7: Remove the stock intake by pulling the factory intake housing straight up out of the mounting grommets.

**Figure E****Refer to Figure E for Step 8**

Step 8: Install your Takeda filter housing ⑧ into the vehicle by lining up the 3 mounting points and pressing down firmly to seat it in the 3 mounting grommets.

**Figure F****Refer to Figure F for Steps 9-10**

Step 9: Install the supplied reducer coupler ⑨ with one of the supplied #048 clamps ⑩ on the throttle body. Tighten the clamp using an 8mm nut driver.

Step 10: Install the remaining #048 clamp ⑩ loosely on the open end of the coupler.

**Figure G****Refer to Figure G for Step 11**

Step 11: Install your aFe POWER air filter (11) into the filter housing by inserting the filter media into the opening on the housing, then pressing firmly until the locking tabs lock on the inside of the housing. Leave the clamp loose on the filter opening.

Figure H

Refer to Figure H for Step 12

Step 12: Using a #1 Phillips screwdriver, remove the 2x screws securing the Mass Airflow Sensor (12) to the factory airbox. Transfer the sensor to your Takeda intake tube, then secure using the 2x supplied M4 screws. Tighten using a T20 Torx driver.

Figure I

Refer to Figure I for Step 13

Step 13: Install the supplied hose nipple (13) into the threaded insert on the side of your Takeda intake tube.

Use an 11mm deep socket and driver to tighten the fitting. ***This is an NPT style fitting – some threads will still be exposed when the fitting is fully tightened. Do not overtighten the fitting or you risk stripping the insert out of the plastic***

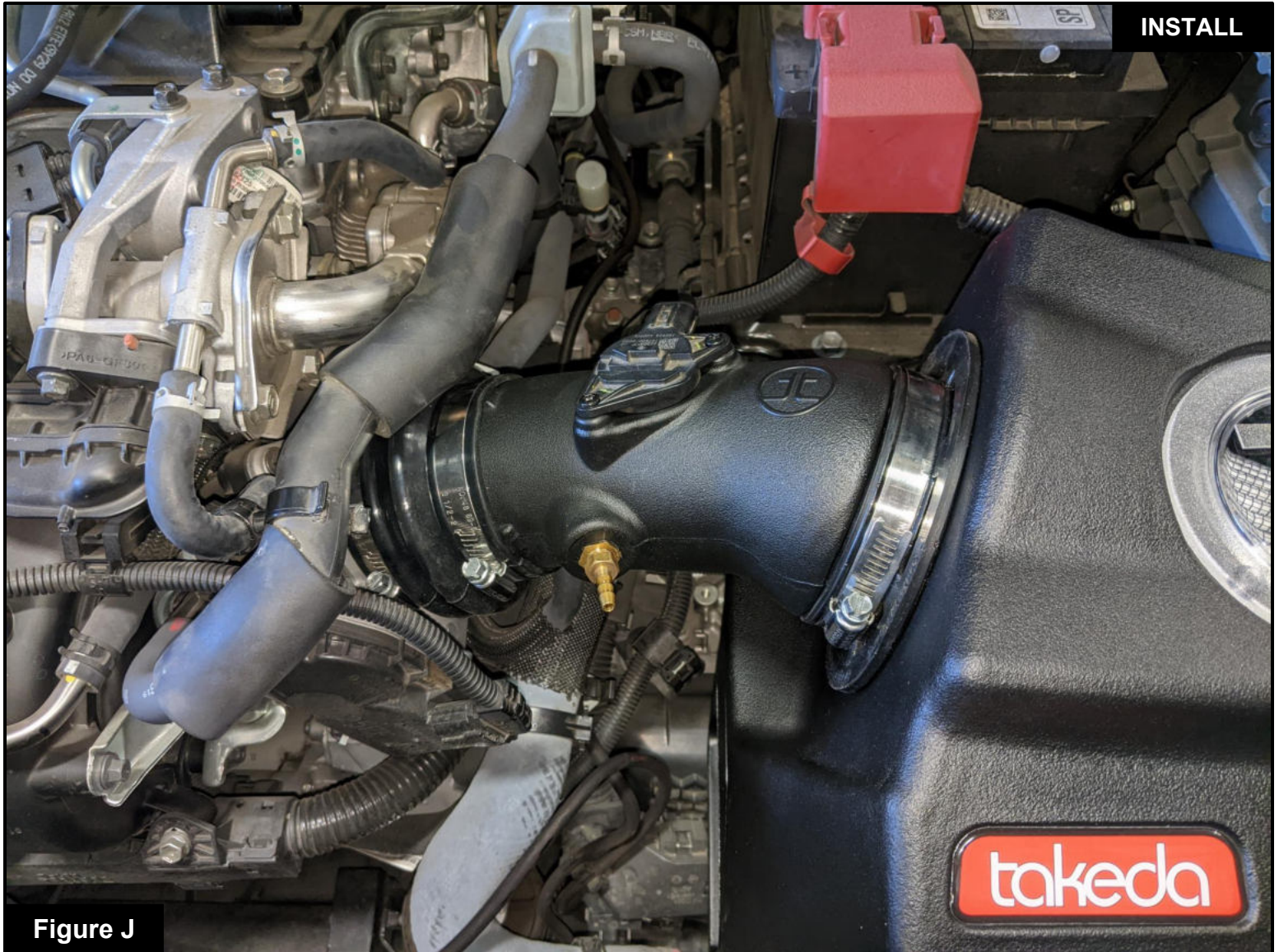

Refer to Figure J for Step 14

Step 14: Install your Takeda intake tube assembly first into the coupler at the throttle body, then into the air filter opening. Tighten both clamps using an 8mm nut driver.

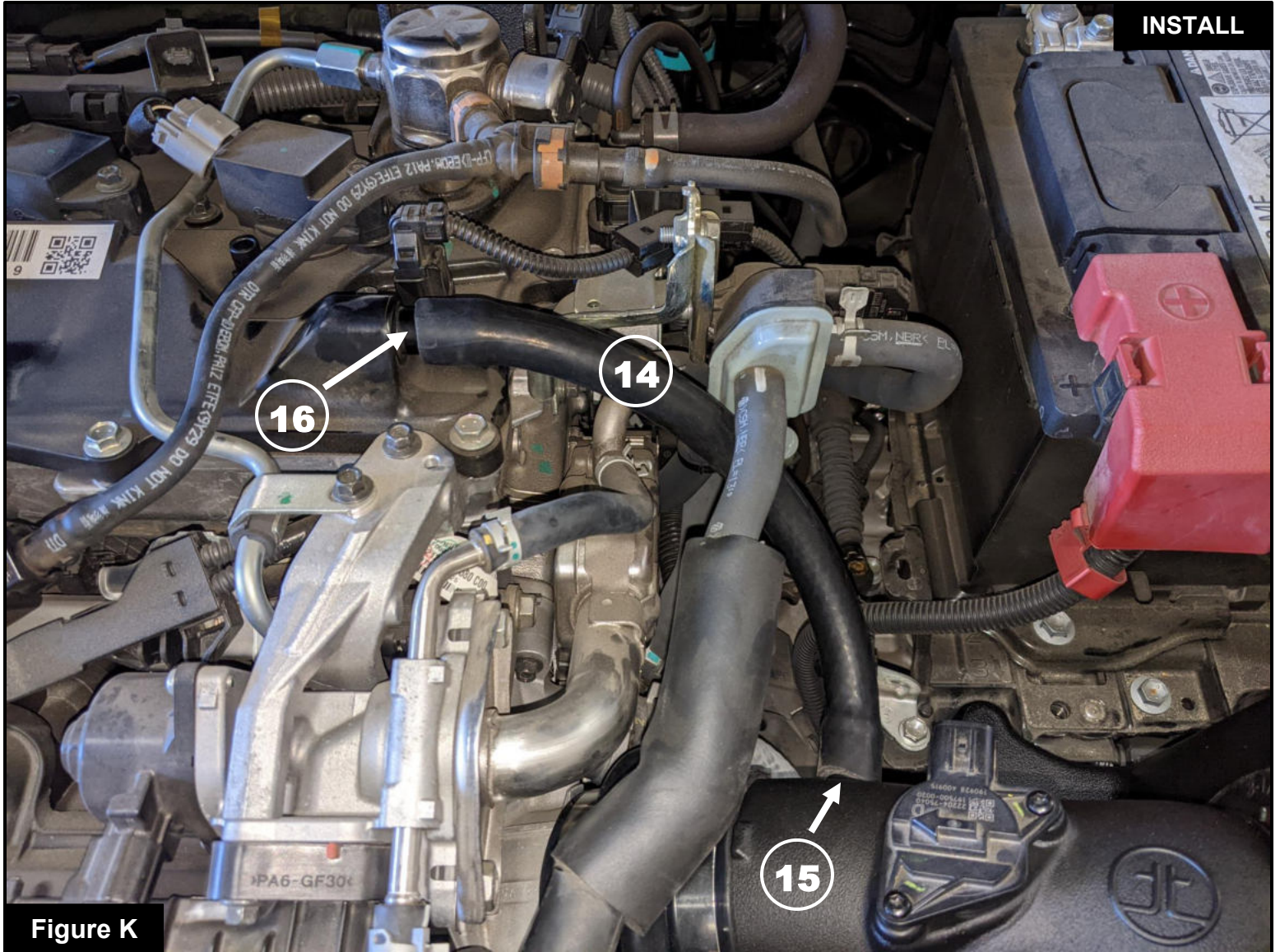

Figure K

Refer to Figure K for Step 15

Step 15: Install the supplied length of 5/8" hose (14) onto the port on your Takeda intake tube (15), then route it underneath the coolant line and connect it to the port on the valve cover (16) .

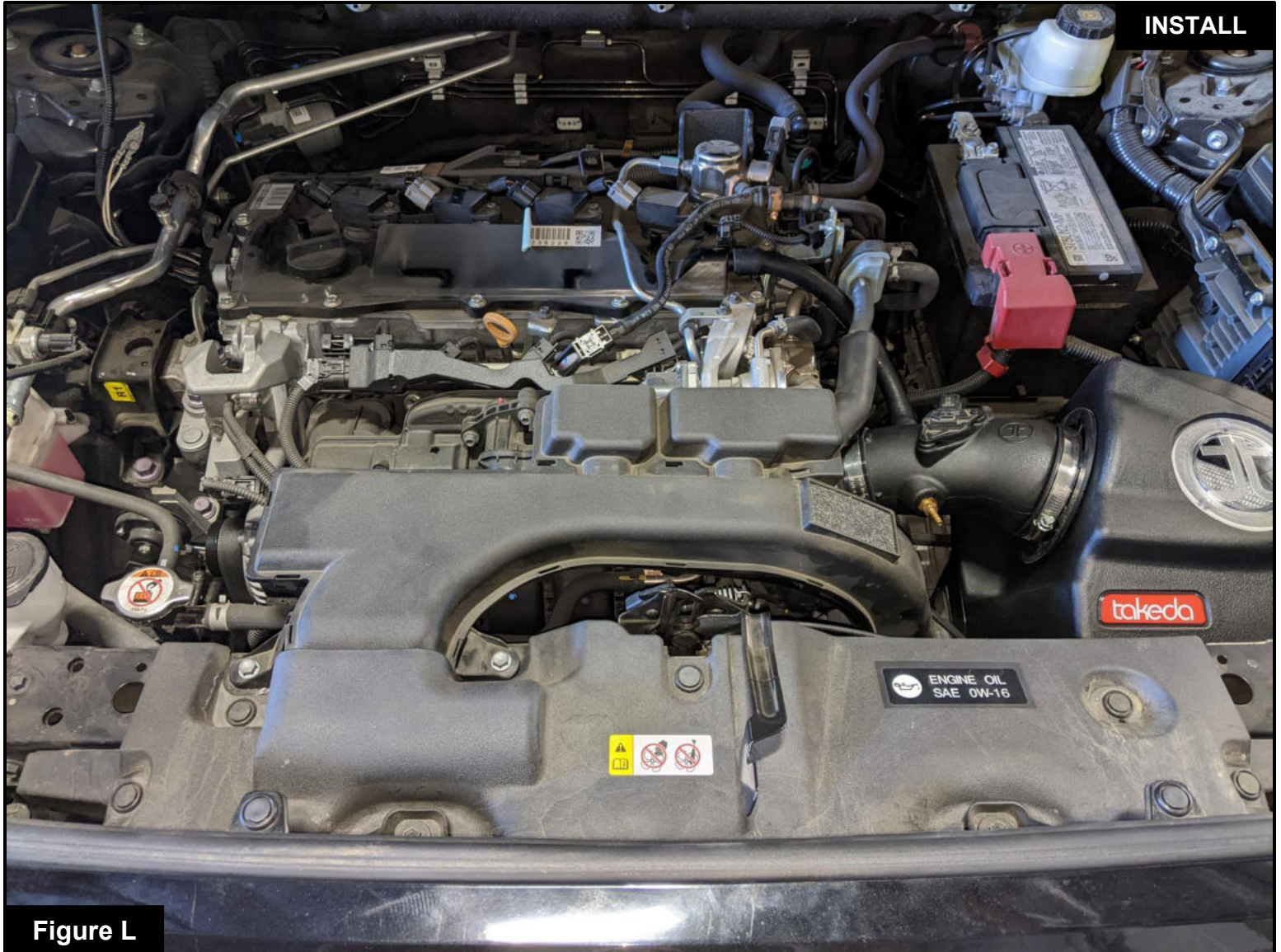

Figure L

Refer to Figure L for Step 16

Step 16: Reinstall your factory inlet scoop by inserting the outlet into the opening on your Takeda filter housing, then securing with the 10mm screws removed in step #5.



Figure M

Refer to Figure M for Step 17

Step 17: Reconnect the Mass Airflow Sensor harness (17) and the small CCV line (18) to your Takeda intake tube.

**Figure N****Refer to Figure N for Step 18**

Step 18: (Optional) Use the provided plug (19) to close the additional air inlet if you want to completely seal the filter housing. Best performance is obtained without the plug.

**Figure O****Refer to Figure O for Steps 19-20**

Step 19: Reinstall your engine cover.

Step 20: Check that all components are tight and secure. Your installation is now complete. Thank you for choose aFe POWER!

NOTE: Check all clamps and connectors are secure after 100-200 miles



THIS PAGE LEFT BLANK INTENTIONALLY



advanced FLOW engineering, inc.

252 Granite Street Corona, CA 92879
TEL: 951.493.7100 • TECH: 951.493.7185
E-Mail: Tech@aFepower.com