

advanced FLOW engineering Takeda Momentum Cold Air Intake System

Instruction Manual P/N: 56-70041D / 56-70041R

Make: Ford

Model: Fiesta ST

Year: 2016-2019

Engine: I4-1.6L (t)



- Please read the entire instruction manual before proceeding.
- Ensure all components listed are present.
- If you are missing any of the components, call customer support at 951-493-7134.
- Ensure you have all necessary tools before proceeding.
- Do not attempt to work on your vehicle when the engine is hot.
- Retain factory parts for future use.

Label	Qty.	Description	Part Number
A1	1	Air Filter (Pro 5R)	TF-9029R
A2	1	Air Filter (Pro DRY S)	TF-9029D
B	1	Tube	05-5670041B1
C	1	Housing	05-5670041B2
D	1	Grommet, Fitting	03-50665
E	1	Fitting, Vacuum	05-01499
F	1	Clamp, 048 (2-9/16" - 3-1/2 ")	03-50007
G	1	Clamp, 044 (2-5/16" - 3-1/4")	03-50019
H	1	Coupling, Silicone Reducer Elbow	05-01691
I	2	Screw, Torx: M4x8mm	03-50491
J	1	Hose, Check Valve	05-01695
K	1	Plug, Silicone Black: 2.25" Dia (Takeda)	05-01527
L	1	Plug, Silicone: 1.4" Dia	05-01387

Installation will require the following tools:

T-20 Torx driver, 7mm and 8mm nut drivers, small flat blade screwdriver, blade

Warranty Information available at <https://afepower.com/contact#warranty>

Emissions Disclaimer: This product is not currently CARB exempt and is not available for purchase in California or for use on any vehicle registered with the California Department of Motor Vehicles.

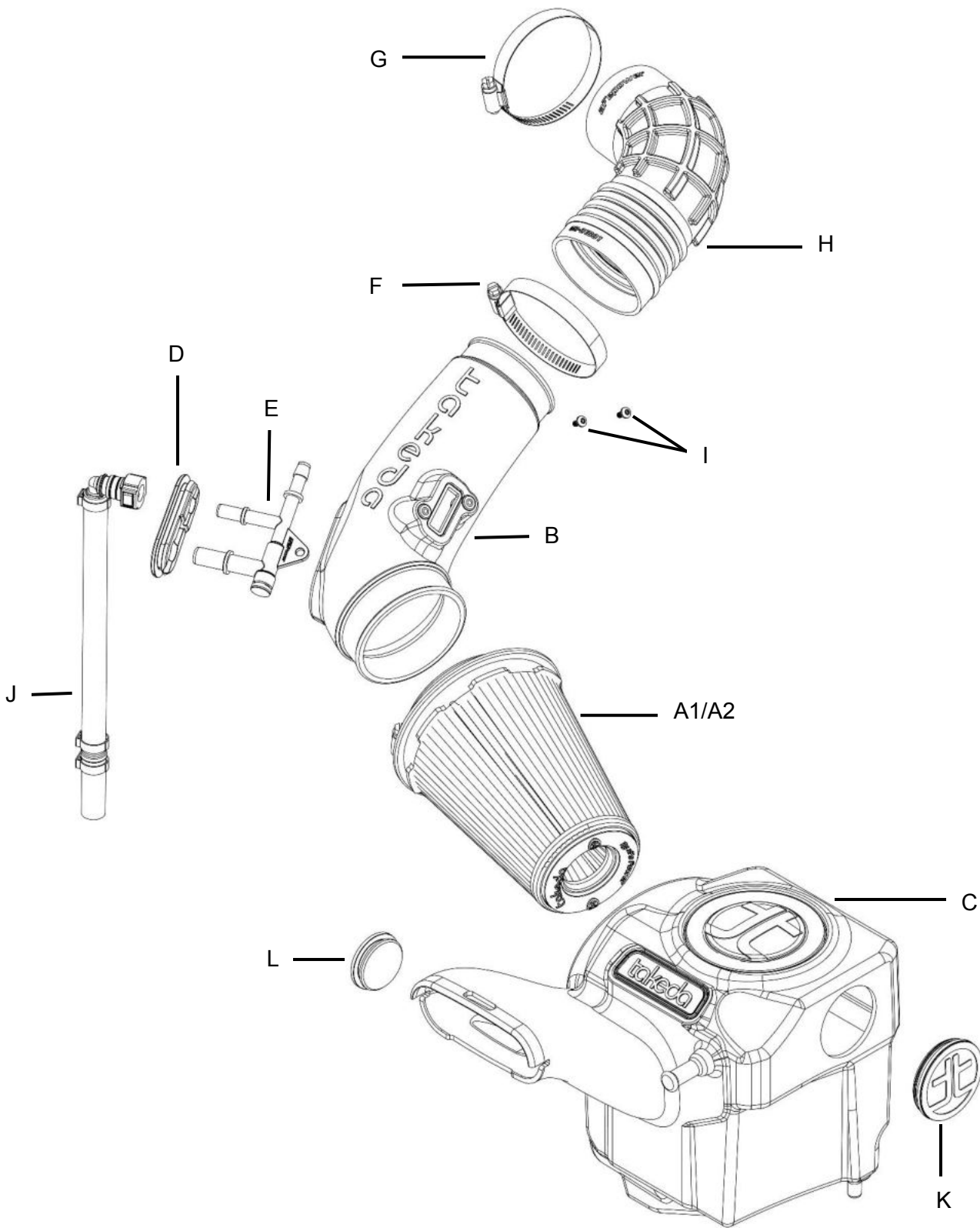

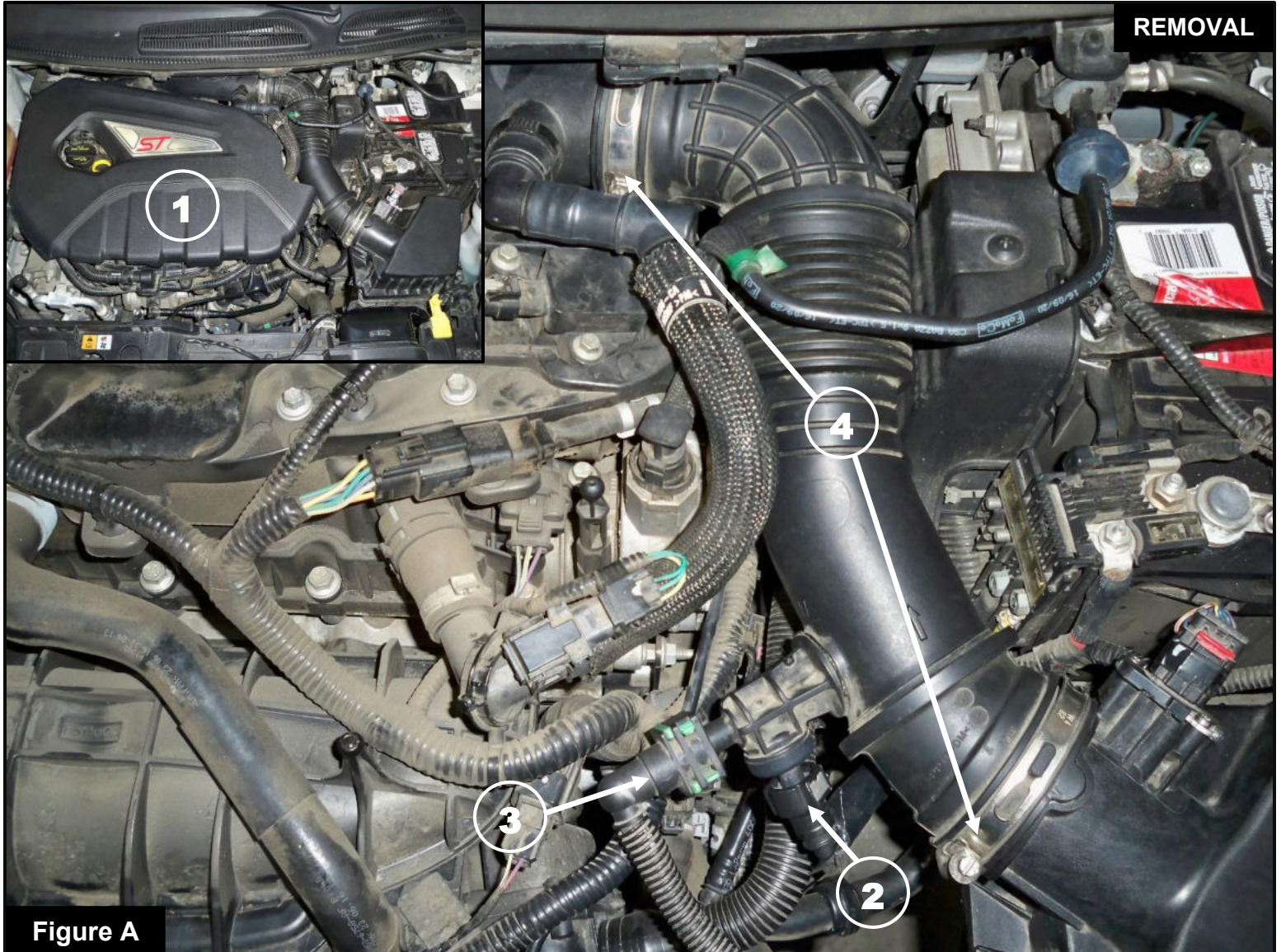

Refer to Figure A for Steps 1-4

Step 1: Remove the engine cover ①.

Step 2: Disconnect the small ② and large ③ quick release connectors.

Step 3: Using a 7mm nut driver, loosen the stock clamps ④ at the turbo tube and at the airbox.

Step 4: Remove the stock intake tube.



Figure B

Refer to Figure B for Steps 5-6

Step 5: Disconnect the MAF sensor (5).

Step 6: Using a small flat blade screwdriver, release the tab (6) at the scoop section and remove the airbox by pulling up to release from its mounting grommets (7) and mounting pin bracket. Make sure the mounting grommets are still in the mounting bracket tabs. If they pulled out and are stuck in the lower half of the airbox, remove them from the airbox and insert them back on the mounting bracket tabs.

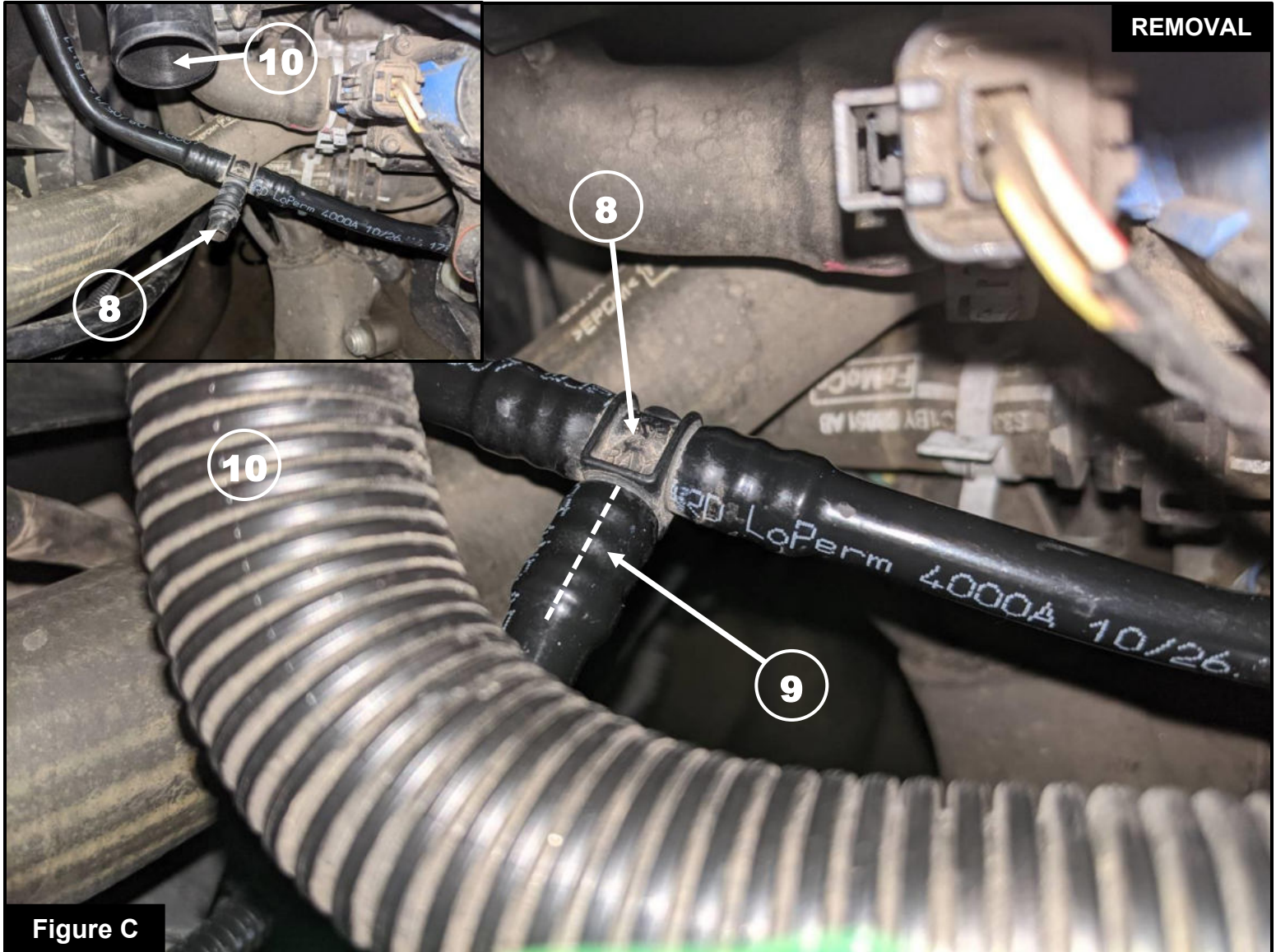

Figure C

Refer to Figure C for Steps 7-8

Step 7: Follow the plastic hose from the disconnected small quick release connector to the tee fitting (8).

Step 8: Using a sharp blade, slice the plastic hose (9) connected to the middle of the tee fitting as shown and remove the plastic hose.

NOTE: You can remove the resonator tube (10) to gain more access to the plastic hose.

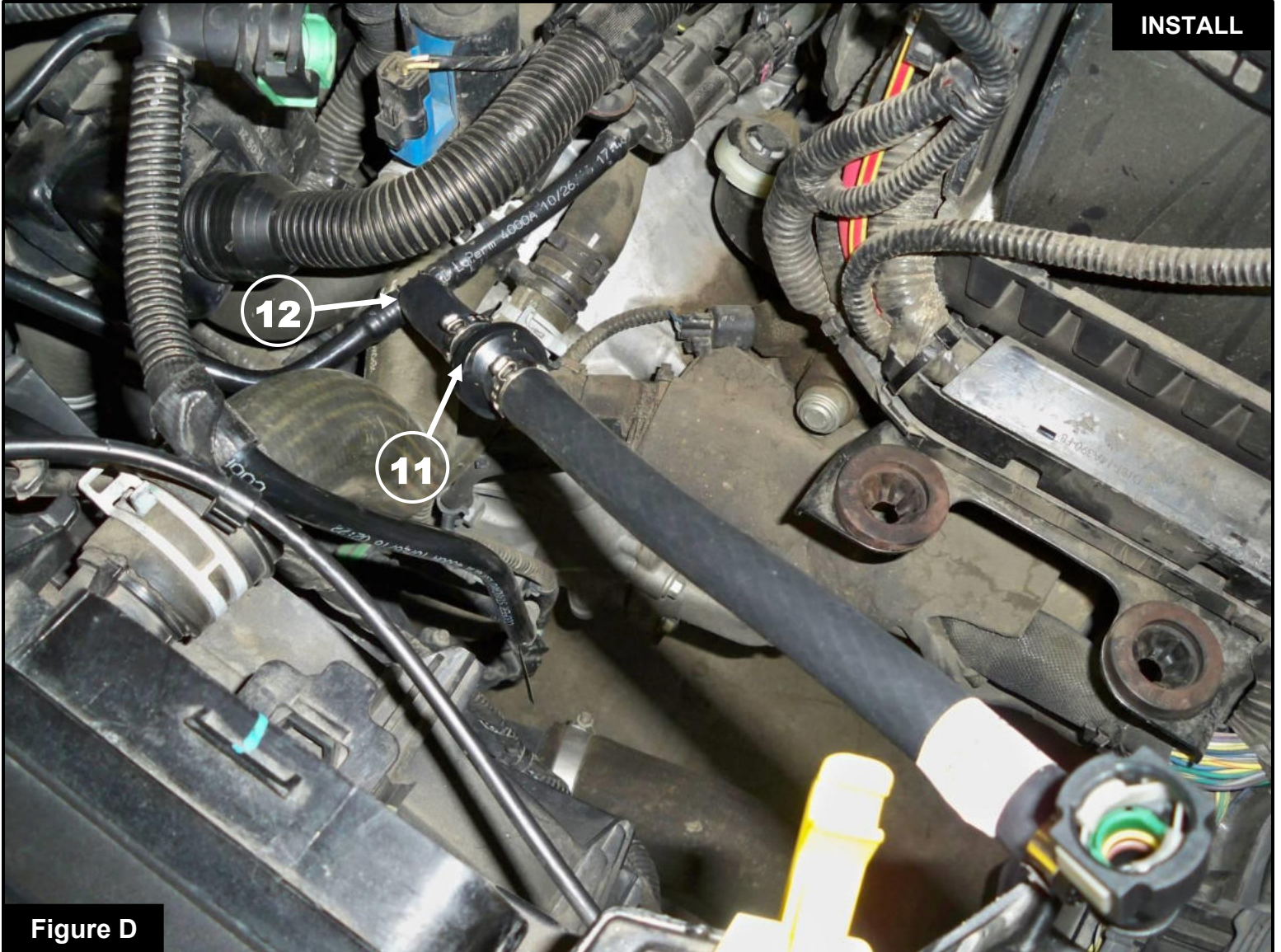
**Figure D****Refer to Figure D for Step 9**

Step 9: Install the supplied check valve hose (11) to the tee fitting (12) as shown. Make sure that it seats all the way in the tee fitting.

**Figure E****Refer to Figure E for Steps 10-11**

Step 10: Insert the supplied vacuum fitting (13) into the supplied fitting grommet (14) as shown. Do not seat the fitting to the grommet at this point so it is easier to install the assembly into the intake tube.

Step 11: Install the fitting and grommet assembly into your Takeda intake tube, making sure the grommet is fully seated by pressing firmly around the edges. Once installed, pull the fitting to fully seat against the grommet exposing the entire quick connect portions (15).

**Figure F****Refer to Figure F for Step 12**

Step 12: Using a Torx T20 driver, remove the MAF sensor (16) from the upper half of the airbox and install it into the Takeda intake tube using the two provided M4 Torx screws.



Figure G

Refer to Figure G for Steps 13-15

Step 13: Remove the rubber isolator (17) from the airbox mounting pin and install it on the Takeda housing mounting pin as shown.

Step 14: Install the small aFe plug (18) into the Takeda housing as shown.

Step 15: Install the large Takeda plug (19) on the side of the Takeda housing as shown.

NOTE: This plug is accessible to be removed and installed at any time to increase airflow and engine sound if desired.

Figure H

Refer to Figure H for Steps 16-17

Step 16: Install the Takeda housing into the vehicle by pushing down the housing pins into the mounting grommets, snapping in the rubber isolator (20) to the mounting pin bracket and inserting the scoop section until the release tab (21) snaps on. Make sure the pins are completely through the mounting grommets and the release tab is holding the housing.

Step 17: Slide the Takeda filter and clamp into the Takeda housing and push it in until it locks into place. Do not tighten the clamp.

Figure I

Refer to Figure I for Steps 18-19

Step 18: Install the supplied silicone coupling (22) onto the turbo tube with the supplied #44 clamp (23) as shown. Do not tighten the clamp.

Step 19: Place the supplied #48 clamp (24) on the silicone coupling as shown. Do not tighten the clamp.

**Figure J****Refer to Figure J for Steps 20-21**

Step 20: Install the Takeda intake tube into the vehicle. Slide the tube into the coupling first and then into the air filter.

Step 21: Align the Takeda intake tube, coupling and clamps correctly, then using an 8mm nut driver tighten all the clamps..



Figure K

Refer to Figure K for Steps 22-23

Step 22: Connect the MAF sensor (25).

Step 23: Lubricate the ends of the vacuum fitting, then connect the large quick release connector (26) and the small quick release connector (27) from the check valve hose.

Step 24: Install the engine cover.

Step 25: Check all the components are tight and secure. Your installation is now complete. Thank you for choosing aFe POWER!

NOTE: Check all bolts, clamps, and connectors after 100-200 miles.



Page left blank intentionally



advanced FLOW engineering, inc.

252 Granite Street Corona, CA 92879
TEL: 951.493.7100 • TECH: 951.493.7134
E-Mail: Tech@aFepower.com