

advanced FLOW engineering

Cold Air Intake System

Instruction Manual P/N: 56-70057D / 56-70057R

Make: Hyundai

Model: Elantra N

Year: 2022-2023

Engine: L4-2.0L(t)



- Please read the entire instruction manual before proceeding.
- Ensure all components listed are present.
- If you are missing any of the components, call customer support at 951-493-7185.
- Ensure you have all necessary tools before proceeding.
- Do not attempt to work on your vehicle when the engine is hot.
- Retain factory parts for future use.

Label	Qty.	Description	Part Number
A	1	Air Filter (Pro 5R) For 56-70057R	24-91144
A	1	Air Filter (Pro DRY S) For 56-70057D	21-91144
B	1	Tube	05-5670057B1
C	1	Housing	05-5670057B2
D	1	Coupling, Silicone Reducer: (2-1/2" x 3") ID x 3'L	05-01736
E	1	Clamp, #048 (2-9/16" - 3-1/2 ")	03-50007
F	1	Clamp, #044 (2-5/16" - 3-1/4")	03-50019
G	1	Fitting, Aluminum 11mm	03-50615
H	1	Plug, Air Box	05-01527

Installation will require the following tools:

8mm and 10mm socket, extension, ratchet, 16mm or adjustable wrench, pliers, and a flat-head screwdriver

Warranty Information available at: <https://afepower.com/contact#warranty>

Emissions Disclaimer: This product is not currently CARB exempt and is not available for purchase in California or for use on any vehicle registered with the California Department of Motor Vehicles.

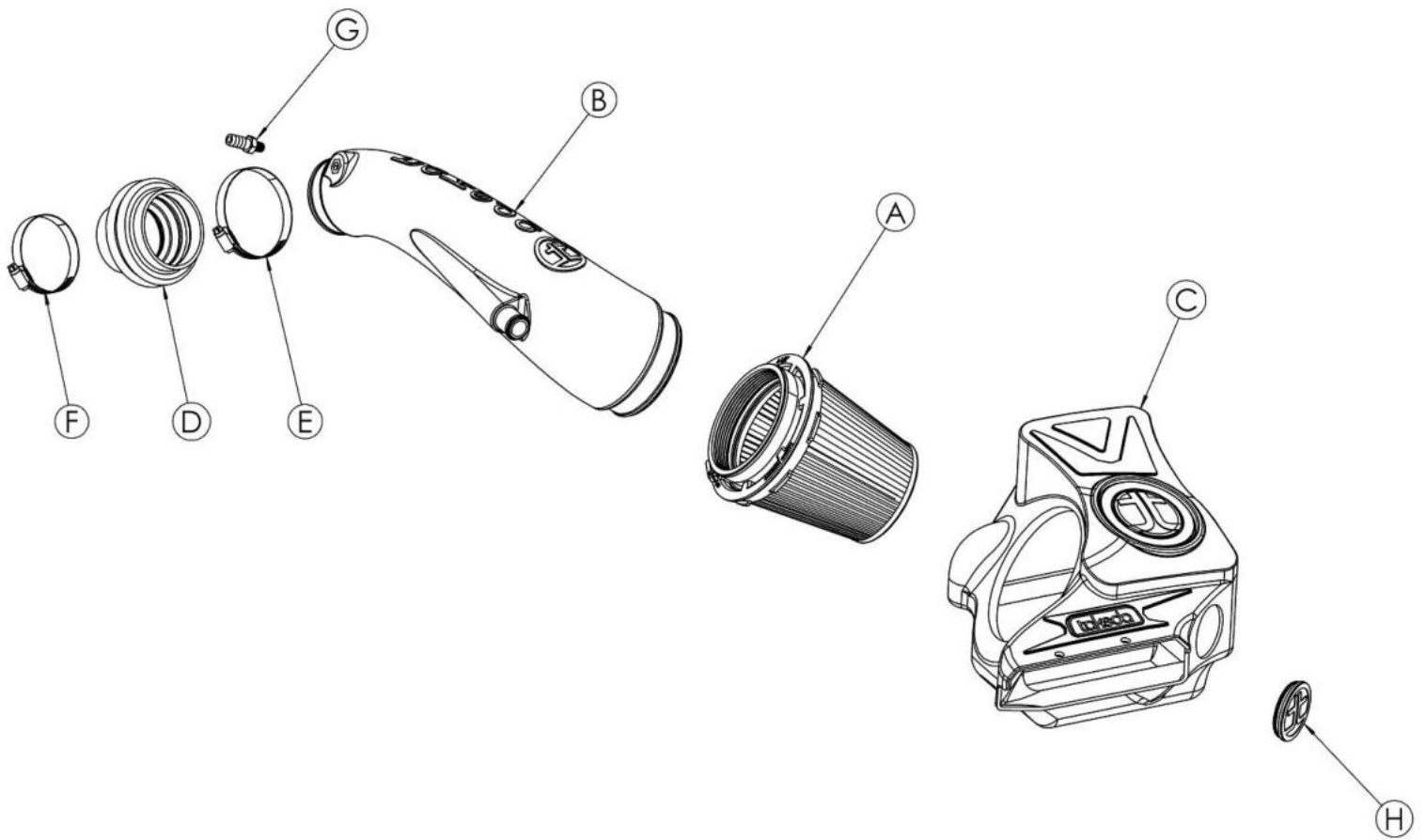

**Figure A****Refer to Figure A for Steps 1-2**

Step 1: Using pliers, open the clamp securing the larger hose to the air intake tube, and then slide the clamp away from the intake tube. This clamp will be re-used. Disconnect the rubber hose from the air intake tube.

Step 2: Using pliers, open the clamp securing the smaller hose to the air intake tube, and then slide the clamp away from the intake tube. This clamp will be re-used. Disconnect the rubber hose from the air intake tube.



Refer to Figure B for Steps 3-4

Step 3: Loosen the clamp at the turbo inlet using a 10mm socket and ratchet.

Step 4: Unclip the two latches at the front of the airbox, then remove the intake tube and the top of the air box from the vehicle.

Note: If the rubber gasket remains when the tube is removed, simply pull it off of the turbo inlet.



Figure C

Refer to Figure C for Steps 5-7

Step 5: Remove the two plastic rivets connecting the factory air inlet to the front of the car. These plastic rivets will be reused.

Step 6: With a 10mm socket, extension and ratchet, loosen the three bolts securing the factory housing to the vehicle. Two of these three bolts will be re-used during the installation of the Takeda air intake system.

Step 7: Remove the bottom of the factory housing and air inlet as one piece out of the vehicle.

05-5670057B2 (CLOSED)
TAKEDA

INSTALL



Figure D

Refer to Figure D for Step 8

Step 8: Transfer two of the mounting grommets and sleeves from the bottom of the factory housing to the Takeda housing.



Figure E

Refer to Figure E for Steps 9-10

Step 9: Install the Takeda housing into the vehicle. Secure it with two of the bolts removed during Step 6.

Step 10: Secure the housing to the air inlet with the two clips removed during Step 5.



Figure F

Refer to Figure F for Step 11

Step 11: Install the air filter into the housing by firmly pushing it into the round opening of the housing until the filter tabs lock it into place.

**Figure G****Refer to Figure G for Step 12**

Step 12: Using a 16mm wrench, install the aluminum fittings into the Takeda air intake tube.

Note: This is an NPT fitting, the small gap between the 16mm hex and the tube is normal.

Figure H

Refer to Figure H for Step 13

Step 13: Install the coupling onto the turbo inlet (the smaller end of the coupling goes onto the turbo inlet).
Install the provided clamps over the coupling, but do not tighten it yet.

**Figure I****Refer to Figure I for Steps 14-15**

Step 14: Install the Takeda intake tube by sliding it into the coupling then into the air filter.

Step 15: Align the tube, filter and coupling then tighten all clamps.

**Figure J****Refer to Figure J for Steps 16-17**

Step 16: Connect the small rubber hose to the aluminum fitting on the tube. Secure it with the factory spring clamp.

Step 17: Connect the bigger rubber hose to the Takeda air intake tube. Secure it with the factory spring clamp.

Figure K

Refer to Figure K for Step 18

Step 18: The kit includes an optional plug to close off the side auxiliary air inlet. Install the plug if you wish to close off the side auxiliary air inlet and only capture cold air from the front.

Without the plug installed, the Takeda intake will capture the maximum air available. More airflow offers more power. Yet some of this air is picked up from inside the engine compartment and could be warmer air. Warmer air will affect the performance of the vehicle.

The plug installed on the housing will block off any hot engine air entering the housing and make sure the coolest air available is directed into the engine. It will also reduce the noise of the intake.



Figure L

Refer to Figure L for Step 19

Step 19: Make sure all clamps and connections are secured. Your installation is now complete. Thank you for choosing Takeda USA!

NOTE: Check all screws, clamps, and connectors are secure after 100-200 miles.



advanced FLOW engineering, inc.

252 Granite Street Corona, CA 92879

<https://afepower.com/contact>