

advanced FLOW engineering Stage-2 Cold Air Intake System

Instruction Manual P/N: 56-10008D / 56-10008R

Make: Honda

Model: Civic

Year: 2016-2020

Engine: I4-1.5L Turbo



- Please read the entire instruction manual before proceeding.
- Ensure all components listed are present.
- If you are missing any of the components, call customer support at 951-493-7100.
- Ensure you have all necessary tools before proceeding.
- Do not attempt to work on your vehicle when the engine is hot.
- Disconnect the negative battery terminal before proceeding.
- Retain factory parts for future use.

Label	Qty.	Description	Part Number
A1	1	Air Filter (Pro 5R)	TF-9028R
A2	1	Air Filter (Pro DRY S)	TF-9028D
B	1	Tube	05-5610008B1
C	1	Housing	05-5610008B2
D	1	Coupling, Silicone Reducer: (2-3/8-2-1/2)"ID x 2-1/2"L	05-01410
E	2	Clamp, 044 (2-5/16"- 3-1/4")	03-50019
F	2	Screw, Torx: M4	05-50491
G	1	Seal, trim : 3/4" Bulb (29"L)	05-01507

Installation will require the following tools:

T-20 Torx driver, 8mm nut driver, small flat-head screwdriver, Philips screwdriver, 10mm deep socket, extension and ratchet.

Warranty Information available at <https://afepower.com/contact#warranty>

Emissions Disclaimer: This product is not currently CARB exempt and is not available for purchase in California or for use on any vehicle registered with the California Department of Motor Vehicles

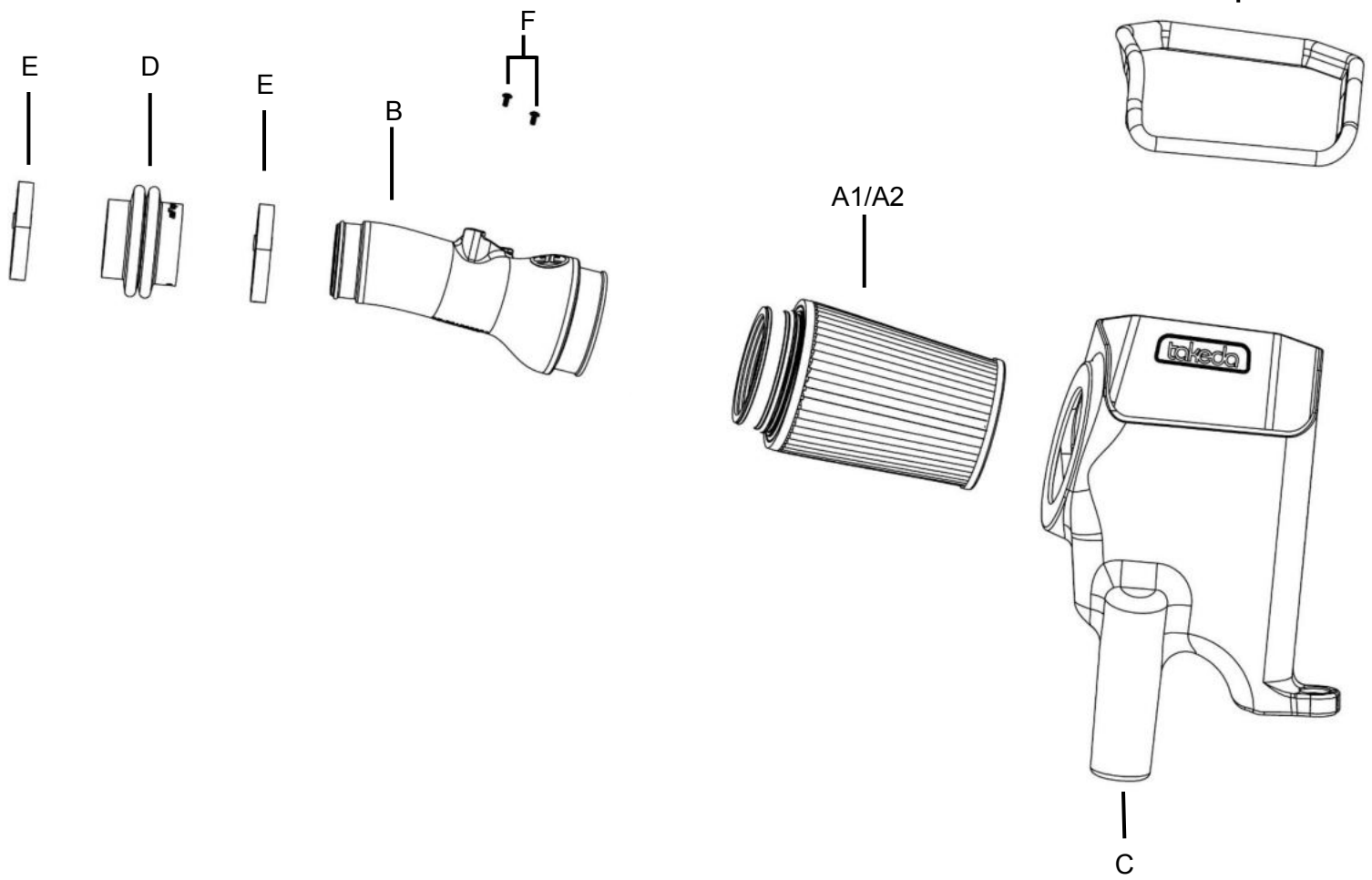

**Figure A****Refer to Figure A for Steps 1-4**

Step 1: Disconnect the Mass Air Flow (MAF) sensor harness ①, With a small flat head screwdriver unclip the harness holder ② and release it from the air box.

Step 2: Loosen the clamp on the factory intake tube connecting to the turbo inlet tube ③.

Step 3: Remove the two 10mm screws retaining the factory housing.

Step 4: With an upward motion remove the factory intake system out of the vehicle.



Figure B

Refer to Figure B for Step 5-6

Step 5: Transfer both factory grommets from the factory intake system to the Takeda housing with the metal inserts (4). Also transfer the factory pop grommet (5).

Step 6: Install the seal trim on the top edge of the Takeda housings.

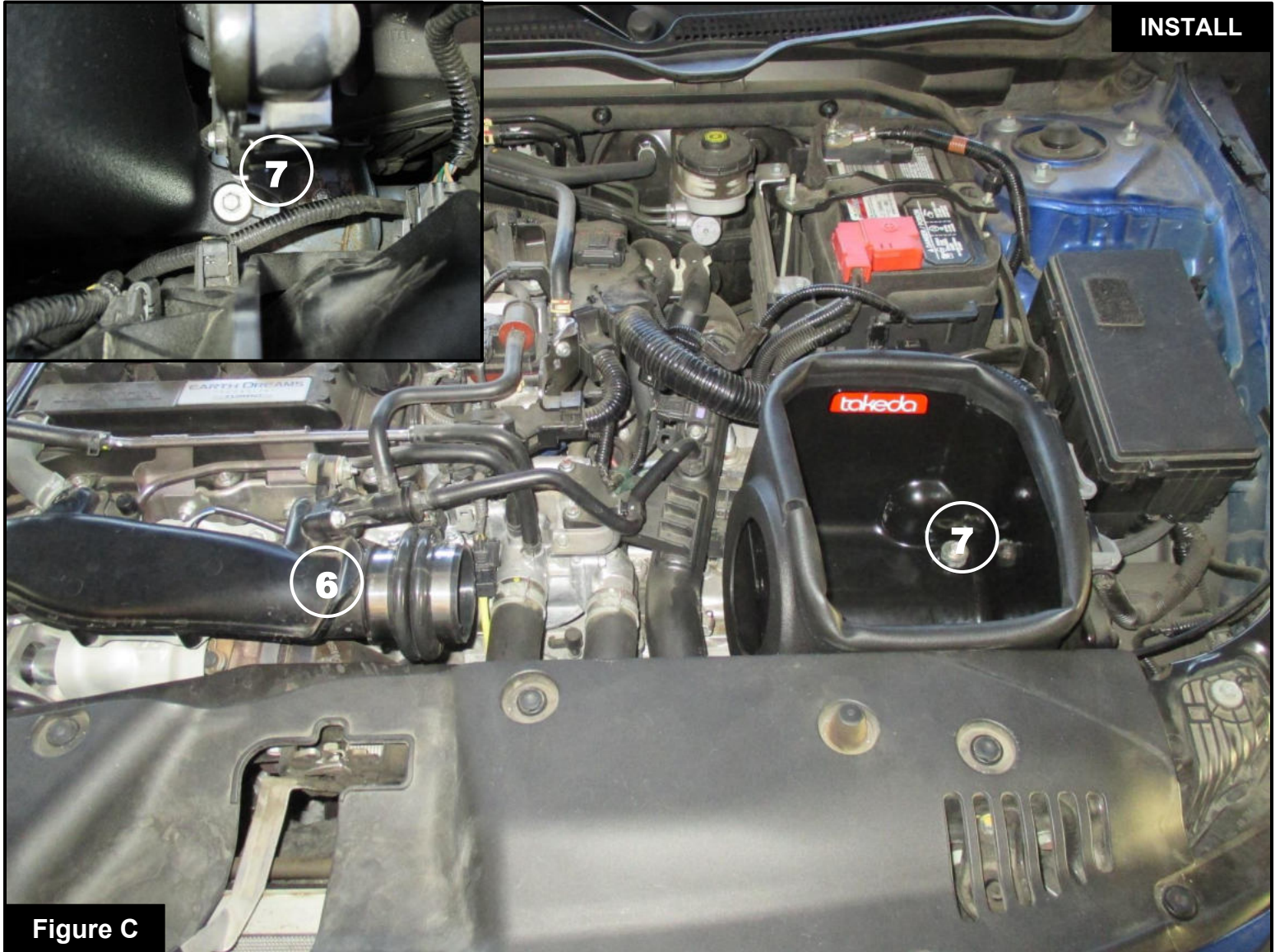

Figure C

Refer to Figure C for Step 7-8

Step 7: Install the coupling onto the turbo inlet with clamps, assure the smaller end goes on the turbo inlet side ⑥. Do not tighten clamps at this time.

Step 8: Install the Takeda housing into the vehicle, secure it with the factory screws onto the factory location ⑦.



Refer to Figure D for Steps 9

Step 9: Install the air filter inside of the Takeda housing. Push the filter through the hole from the inside of the housing until it locks in place. Install clamp on the filter end but do not tighten at this time ⑧



Figure E

Refer to Figure E for Steps 10

Step 10: Transfer the MAF sensor from the factory housing to the Takeda intake tube. Secure it with the M4 screws provided.



Refer to Figure F for Step 11-13

Step 11: Slide the intake tube into the air filter then into the coupling. Align coupling, tube and air filter then tighten all clamps.

Step 12: Re-connect MAF sensor harness.

Step 13: Make sure all clamps and connections are secured. Your installation is now completed.

NOTE: Check all bolts, clamps and connectors after 100-200 miles.

PAGE LEFT BLANK INTENTIONALLY

PAGE LEFT BLANK INTENTIONALLY



advanced FLOW engineering, inc.

252 Granite Street Corona, CA 92879

<https://afepower.com/contact>