

## ***advanced FLOW engineering***

Cold Air Intake System

**Instruction Manual** P/N: 56-50056D / 56-50056R

Make: **Toyota**  
Make: **Subaru**

Model: **GR86**  
Model: **BRZ**

Year: **2022-2023**  
Year: **2022-2023**

Engine: **H4-2.4L**  
Engine: **H4-2.4L**



- Please read the entire instruction manual before proceeding.
- Ensure all components listed are present.
- For technical support please call at 951-493-7185.
- Ensure you have all necessary tools before proceeding.
- Do not attempt to work on your vehicle when the engine is hot.
- Retain factory parts for future use.

Label	Qty.	Description	Part Number
A	1	Air Filter (Pro DRY S) for 56-50056D	31-10324
A	1	Air Filter (Pro 5R) for 56-50056R	30-10324
B	1	Tube, silicone (Black)	05-5650056B1
C	1	Clamp, #052	03-50008

**Installation will require the following tools:**

Socket set, socket wrench, screwdriver, pliers.

Warranty information available at <https://afepower.com/contact#warranty>.

**Emissions Disclaimer:**

This product is not currently CARB exempt and is not available for purchase in California or for use on any vehicle registered with the California Department of Motor Vehicles.

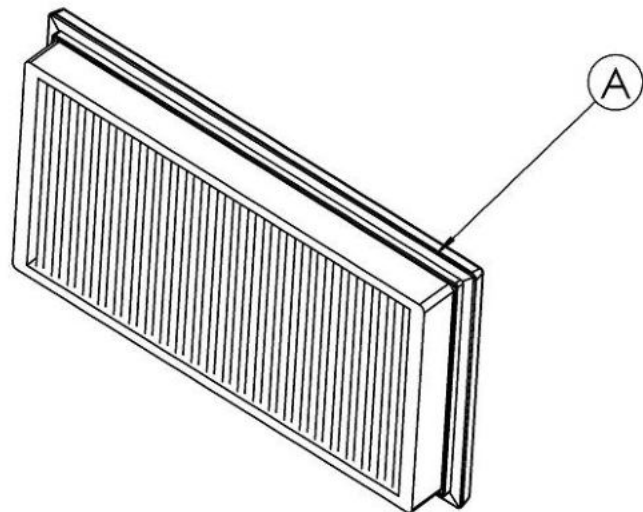
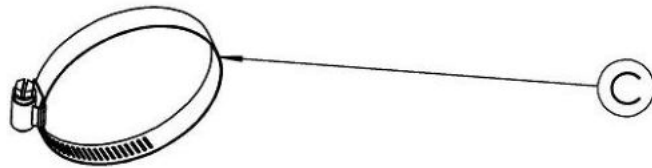
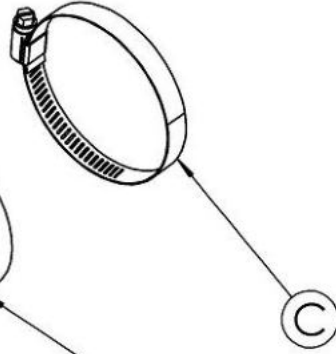
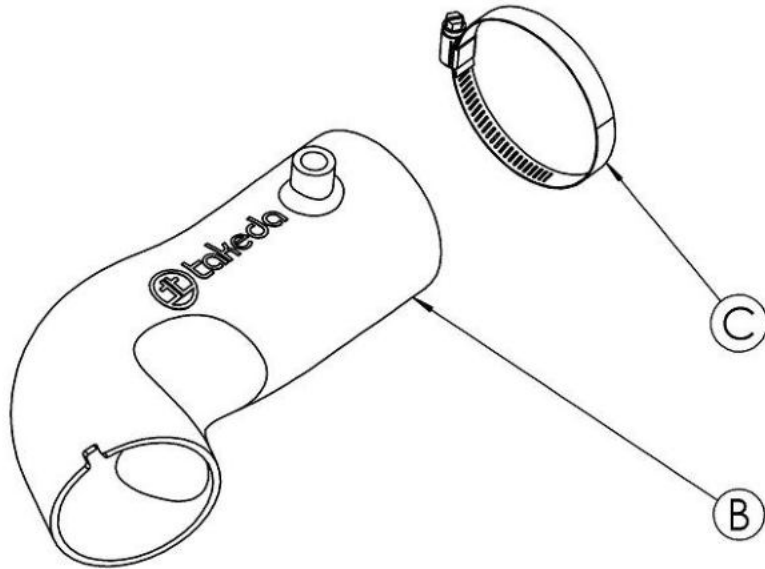



**Refer to Figure A for Steps 1-3**

Step 1: Disconnect the crankcase (CCV) fitting from the factory intake tube. Keep the pinch clamp for later use.

Step 2: Loosen the clamps on both ends of the factory intake tube.

Step 3: Remove the factory intake tube from the vehicle.

**Figure B****Refer to Figure B for Steps 4-6**

Step 4: Detach the two (2) clips on top of the factory airbox. Then remove the factory air filter.

Step 5: Install the supplied air filter.

Step 6: Close the airbox halves together again with the two (2) clips.

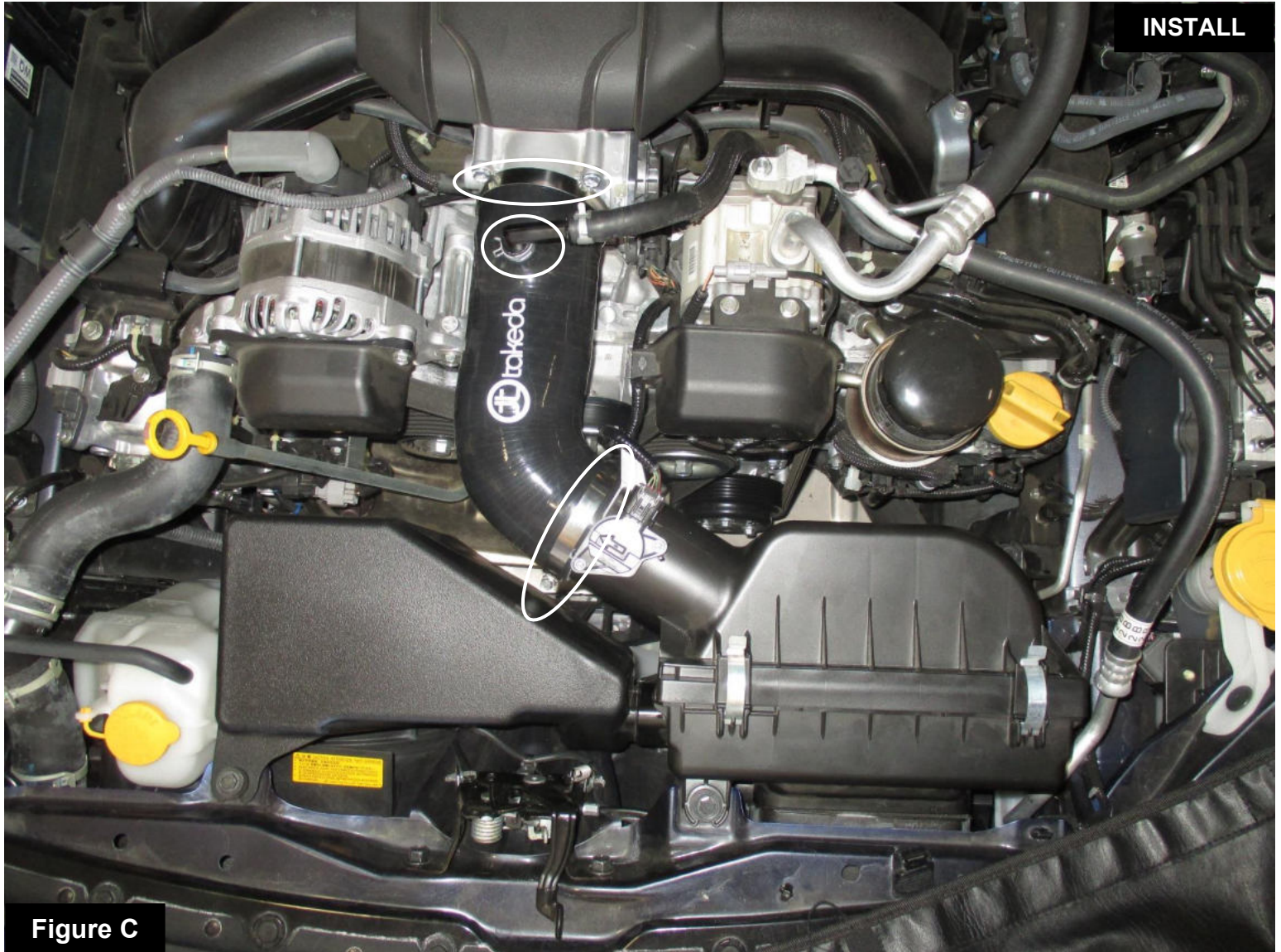

### **Refer to Figure C for Steps 7-11**

Step 7: Install the Takeda intake tube into the vehicle with the two supplied clamps.

Step 8: Line the Takeda intake tube between the throttle body and the factory airbox, making sure the notch on the factory airbox aligns with the Takeda intake tube.

Step 9: Tighten the two (2) supplied clamps on the Takeda intake tube.

Step 10: Insert the factory CCV fitting into the Takeda intake tube, then secure with the factory pinch clamp.

Step 11: Make sure all components and connections are secure. Your installation is now complete. Thank you for choosing Takeda!

**NOTE: Check all clips, clamps, and connectors after 100-200 miles.**



Page Left Blank Intentionally



***advanced FLOW engineering, inc.***

252 Granite Street Corona, CA 92879

<https://afepower.com/contact>