

advanced FLOW engineering Track Series Cold Air Intake System

Instruction Manual P/N: 57-10002D / 57-10002R

Make: Jeep Model: Grand Cherokee (WK2) Trackhawk Year: 2018 Engine: V8-6.2L(sc) HEMI



- Please read the entire instruction manual before proceeding.
- Ensure all components listed are present.
- If you are missing any of the components, call customer support at 951-493-7100.
- Ensure you have all necessary tools before proceeding.
- Do not attempt to work on your vehicle when the engine is hot.
- Disconnect the negative battery terminal before proceeding.
- Retain factory parts for future use.

Label	Qty.	Description	Part Number
A1	1	Air Filter (Pro DRY S)	21-90112
A2	1	Air Filter (Pro 5R)	24-90112
B	1	Tube	05-5710002C1
C	1	Housing	05-5710002B2
D	1	Coupling, Silicone Bellow: (3.9"x4.35")ID x 30Deg	05-01495
E	1	Clamp, T-bolt (4-1/16" - 4-3/8") (SS)	03-50262
F	1	Clamp, T-bolt (4-9/16" - 4-7/8") (SS)	03-50319
G	1	Seal, Trim: 3/4" (32"L)	05-01507

Installation will require the following tools:

8mm and 11mm nut driver or socket, socket wrench, flat-head screwdriver, and panel popper.

Warranty Information available at <https://afepower.com/contact#warranty>

Emissions Disclaimer: This product is not currently CARB exempt and is not available for purchase in California or for use on any vehicle registered with the California Department of Motor Vehicles.

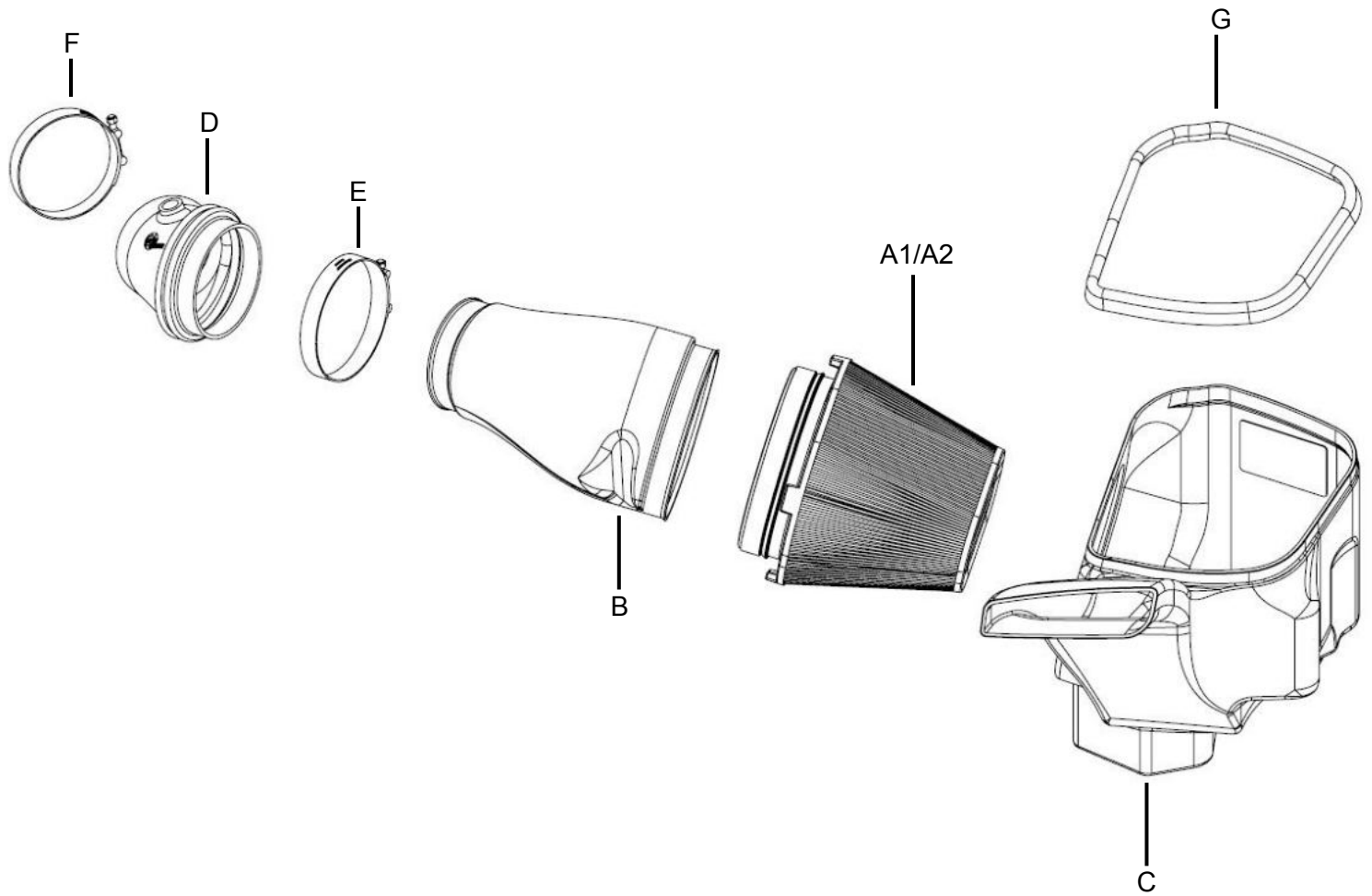

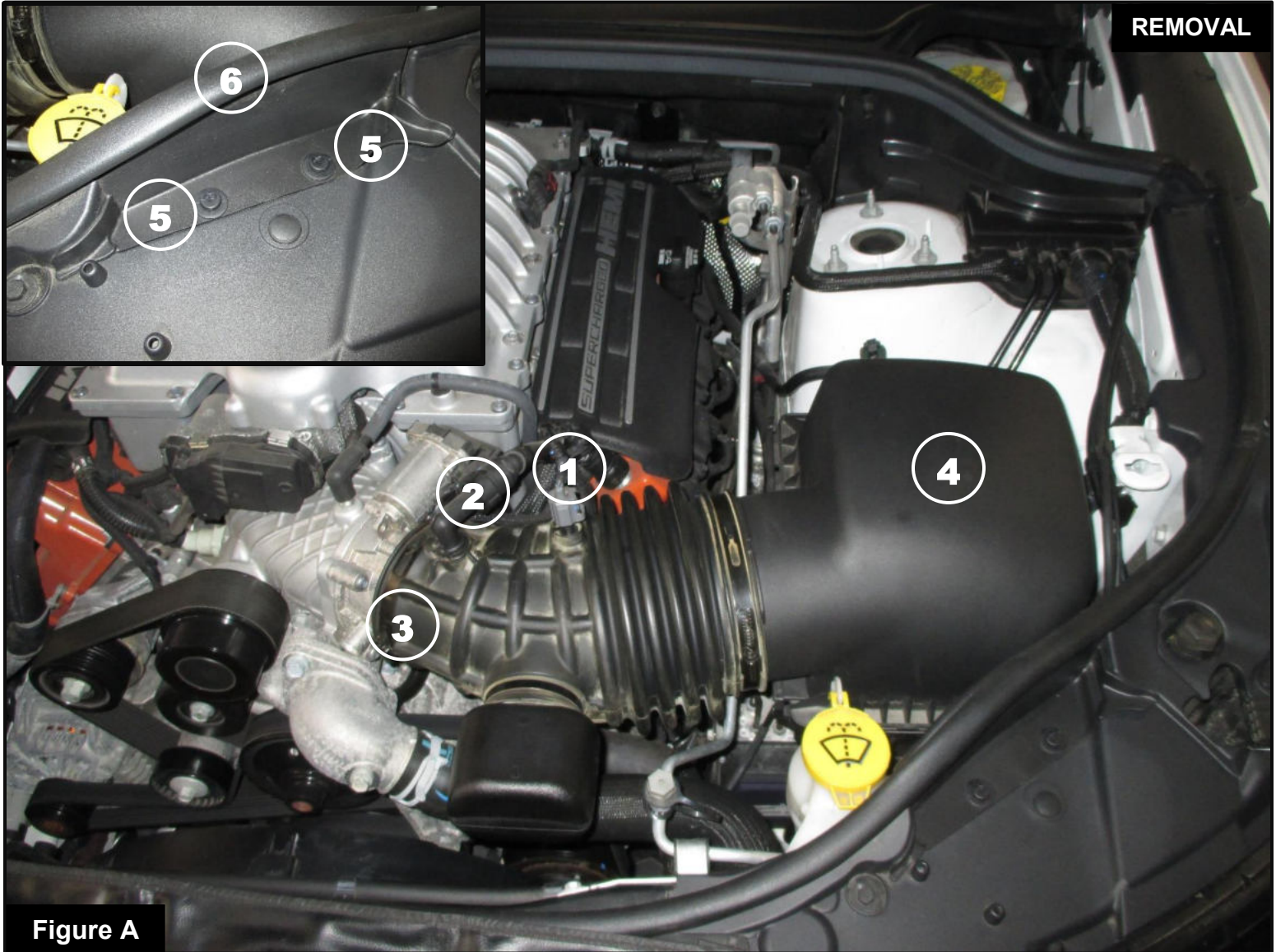

REMOVAL

Figure A

Refer to Figure A for Steps 1-5

Step 1: Disconnect the temp sensor ①.

Step 2: Remove the crankcase breather line ② by carefully pulling it out of the factory intake tube.

Step 3: Using an 8mm nut driver, loosen the hose clamps at the throttle body ③.

Step 4: To remove the factory intake, carefully pull the factory intake tube away from the throttle body and pull up on the factory airbox ④.

Step 5: To remove the factory block off plate, use a panel popper to remove the two (2) pins ⑤ and the factory trim seal, detaching three (3) clips ⑥.



Figure B

Refer to Figure B for Step 6

Step 6: Transfer the three (3) factory grommets from the factory airbox to the aFe Power housing (7).

**Figure C****Refer to Figure C for Steps 7-8**

Step 7: Install the supplied air filter in to the aFe Power housing (8).

Step 8: Install the supplied trim seal on the top edge of the aFe Power housing (9).



Figure D

Refer to Figure D for Step 9

Step 9: Install the supplied coupling and clamps onto the throttle body ⑩. Do not tighten the clamps.



Figure E

Refer to Figure E for Step 10

Step 10: Transfer the temp sensor from the factory intake tube to the carbon fiber aFe Power intake tube (11).

**Figure F****Refer to Figure F for Step 11**

Step 11: Insert the aFe Power intake tube into the pre-assembled aFe Power housing and air filter (12).

Do NOT tighten the clamp at this time.



Figure G

Refer to Figure G for Steps 12-16

Step 12: Install the assembled aFe Power intake into the engine bay. Slide the aFe Power intake tube into the coupling at the throttle body.

Step 13: Adjust the aFe Power intake tube and connect the temp sensor harness to the temp sensor ⑬.

Step 14: Press the crankcase breather line into the coupling ⑭, then tighten the clamps at the coupling and air filter.

Step 15: Re-attach the factory trim seal from **Step 5** ⑮ into the aFe Power housing.

Step 16: Make sure all components and connections are secure. Your installation is now complete. Thank you for choosing aFe Power!

NOTE: Check all bolts, clamps, and connectors after 100-200 miles.



Page left blank intentionally.



advanced FLOW engineering, inc.

252 Granite Street Corona, CA 92879

<https://afepower.com/contact>