

advanced FLOW engineering

Cold Air Intake System

Instruction Manual P/N: 57-10005D / 57-10005R

Make: Chevrolet **Model:** Camaro SS **Year:** 2016-2022 **Engine:** V8-6.2L



- Please read the entire instruction manual before proceeding.
- Ensure all components listed are present.
- If you are missing any of the components, call customer support at 951-493-7185.
- Ensure you have all necessary tools before proceeding.
- Do not attempt to work on your vehicle when the engine is hot.

Retain factory parts for future use.

Label	Qty.	Description	Part Number
A1	1	Air Filter (Pro 5R)	24-91119
A2	1	Air Filter (Pro DRY S)	21-91119
B	1	Tube	05-13052C1
C	1	Housing	05-13052B2
D	1	Seal, Trim: 7/16" (32" inches)	05-00072
E	1	Coupling, Silicone Bellow	05-01375
F	1	Fitting, Vent	05-01339
G	2	T-bolt Clamp	03-50265
H	2	Screw, M4	03-50491
I	2	Washer, Lock: M6	03-50071
J	2	Screw, Hex Hd: M6	03-50052
K	2	Washer, Flat: M6	03-50070
L	1	Cap, Vinyl	03-50623

Installation will require the following tools:

10mm & 8mm nut driver, 11mm deep socket & driver, T20 Torx, flathead screwdriver, 20mm wrench or adjustable wrench and pliers.

Warranty Information available at: <https://afepower.com/contact#warranty>

Emissions Disclaimer:

This product is not currently CARB exempt and is not available for purchase in California or for use on any vehicle registered with the California Department of Motor Vehicles.

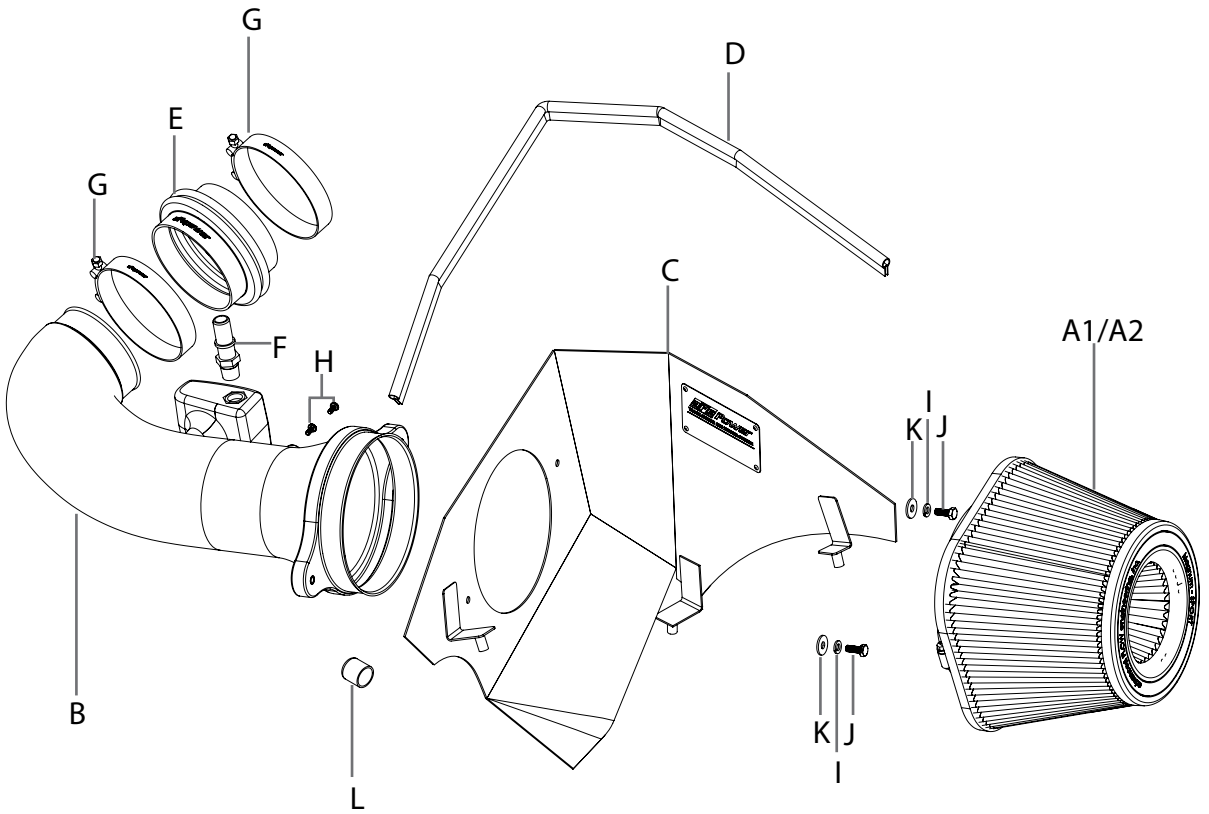

**Figure A**

Refer to Figure A for Steps 1-2

Step 1: Using a pair of pliers, disconnect the sound hose ① from the intake tube. Disconnect the MAF sensor ② and the breather hose ③ from the intake tube .

Step 2: Use an 8mm nut driver to loosen the stock clamps ④ at the throttle body and the airbox. Remove the stock intake tube.



Refer to Figure B for Steps 3-4

Step 3: Remove the air hose from the captive clamp⑤ and move it to the side.

Step 4: Remove the airbox by pulling up to release airbox from its mounting grommets⑥. Make sure the mounting grommets⑥ are still in the chassis mounting tabs. If they pulled out and are stuck in the lower half of the airbox, remove them from the airbox and insert them back on the chassis mounting tabs.



Figure C

Refer to Figure C for Steps 5-6

Step 5: Install the supplied silicone coupling (7) with one of the supplied T-bolt clamps (8). Tighten the clamp at the throttle body.

Step 6: Place the other T-bolt clamp on the coupling, but do not tighten at this time.



Refer to Figure D for Step 7

Step 7: Using a flat blade screwdriver, loosen the clamp (9) at the sound chamber and remove the hose. Plug the chamber with the supplied cap (10).



Figure E

Refer to Figure E for Step 8

Step 8: Install the trim seal (11) onto the aFe housing, then install the housing assembly into the vehicle by pushing down the housing pins into the rubber grommets. Make sure the pins are completely through the mounting grommets.



Figure F

Refer to Figure F for Step 9

Step 9: Using a Torx 20 driver remove the mass air flow sensor (12) from the upper half of the airbox and set it aside.



FigureG

Refer to Figure G for Steps 10-11

Step 10: Install the supplied aluminum vent fitting (13) into the aFe intake tube using a 20mm wrench or adjustable wrench.

Step 11: Install the mass air flow sensor (14) on the aFe intake tube using the two supplied M4 screws.



Figure H

Refer to Figure H for Steps 12-14

Step 12: Install the aFe intake tube into the round opening in the housing and then into the bellows coupling.

Step 13: Insert the M6 screws (15) through the lock washers then through the flat washers. Secure the intake tube to the housing with the screws.

Step 14: Tighten the T-bolt clamp (16) at the coupling.



Figure 1

Refer to Figure 1 for Step 15

Step 15: Install the air filter onto the intake tube opening. Align the filter and tighten the clamp.



Figure J

Refer to Figure J for Steps 16-17

Step 16: Reconnect the MAF sensor (17) and breather hose (18).

Step 17: Check all the components are tight and secure. Your installation is now complete. Thank you for choosing aFe POWER!



PAGE LEFT BLANK INTENTIONALLY

PAGE LEFT BLANK INTENTIONALLY



advanced FLOW engineering, inc.
252 Granite Street Corona, CA 92879
<https://afepower.com/contact>