

advanced FLOW engineering

Track Series Cold Air Intake System

Instruction Manual P/N: 57-10011D / 57-10011R

Make: RAM

Model: 1500

Year: 2019-2023

Engine: V8-5.7L HEMI



- Please read the entire instruction manual before proceeding.
- Ensure all components listed are present.
- For technical support please call 951-493-7185.
- Ensure you have all necessary tools before proceeding.
- Do not attempt to work on your vehicle when the engine is hot.
- Retain factory parts for future use.

Label	Qty.	Description	Part Number
A1	1	Air Filter (Pro 5R)	24-91149
A2	1	Air Filter (Pro DRY S)	21-91149
B	1	Housing	05-5710011B2
C	1	Carbon Fiber Tube	05-5710011C1
D	1	Seal, Trim: Double Bulb (43"L)	05-01534
E	1	Coupling, Silicone Reducer	05-01508
F	1	Fitting, Vent Tube (Large)	05-01339
G	1	Clamp, T-bolt (3-13/16" – 4-1/8")	03-50265
H	1	Clamp, T-bolt (3-9/16" – 3-7/8")	03-50007

Installation will require the following tools:

8mm nut driver, 11mm deep socket and ratchet, 20mm wrench or adjustable wrench.

Warranty Information available at <https://afepower.com/contact#warranty>

Emissions Disclaimer: This product is not currently CARB exempt and is not available for purchase in California or for use on any vehicle registered with the California Department of Motor Vehicles.

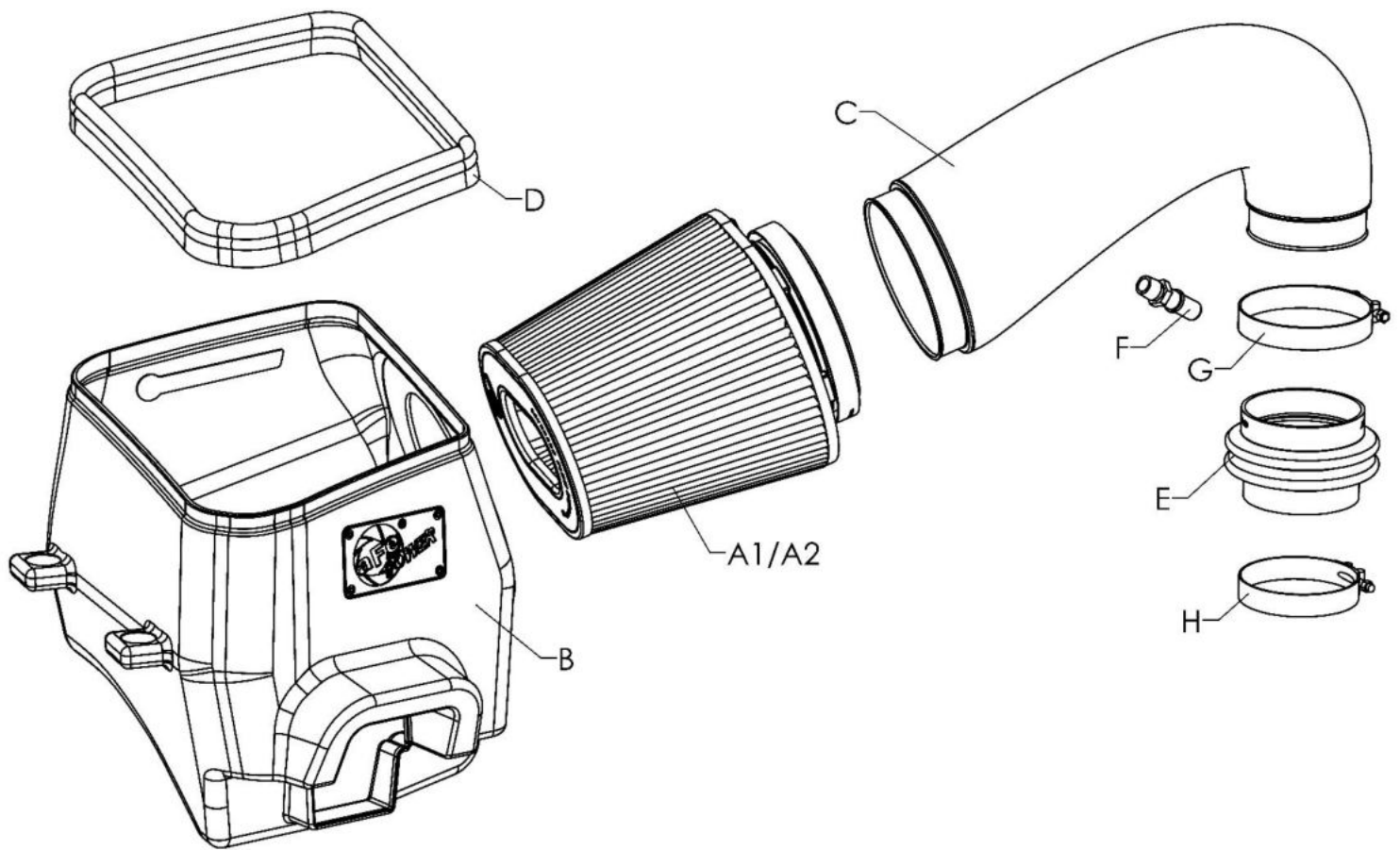



Figure A

Refer to Figure A for Steps 1-4

Step 1: Using an 8mm nut driver, loosen the clamps at the throttle body (1) and factory filter housing (2).

Step 2: Disconnect the crank case breather fitting (3) from the factory intake tube.

Step 3: Disconnect the temperature sensor wire harness (4) from the temperature sensor.

Step 4: Remove the factory intake tube.



REMOVAL

Figure B

Refer to Figure B for Step 5

Step 5: Remove the factory filter housing by pulling straight up off the mounting grommets.



Figure C

Refer to Figure C for Step 6

Step 6: Transfer the four grommets (5) from the factory filter housing to your aFe POWER housing in the locations shown.

**Figure D****Refer to Figure D for Step 7**

Step 7: Install the supplied seal trim (6) along the top opening of your aFe POWER housing. Trim to fit as needed.

**Figure E****Refer to Figure E for Step 8**

Step 8: Install your aFe POWER housing into the vehicle, lining up the four mounting pegs with the grommets in the airbox, and pressing down lightly.

**Figure F****Refer to Figure F for Step 9**

Step 9: Remove the filter clamp (7) from the aFe POWER air filter. Slide the filter into your aFe POWER housing from the top, then guide the filter flange through the round opening in the housing, snapping the filter into place. Place the clamp back on the filter flange.

**Figure G****Refer to Figure G for Step 10**

Step 10: Install your aFe Power reducer coupler (8) with the small side on the throttle body along with the TB387SS T-bolt clamp (9). Tighten the clamp using an 11mm deep socket and driver.

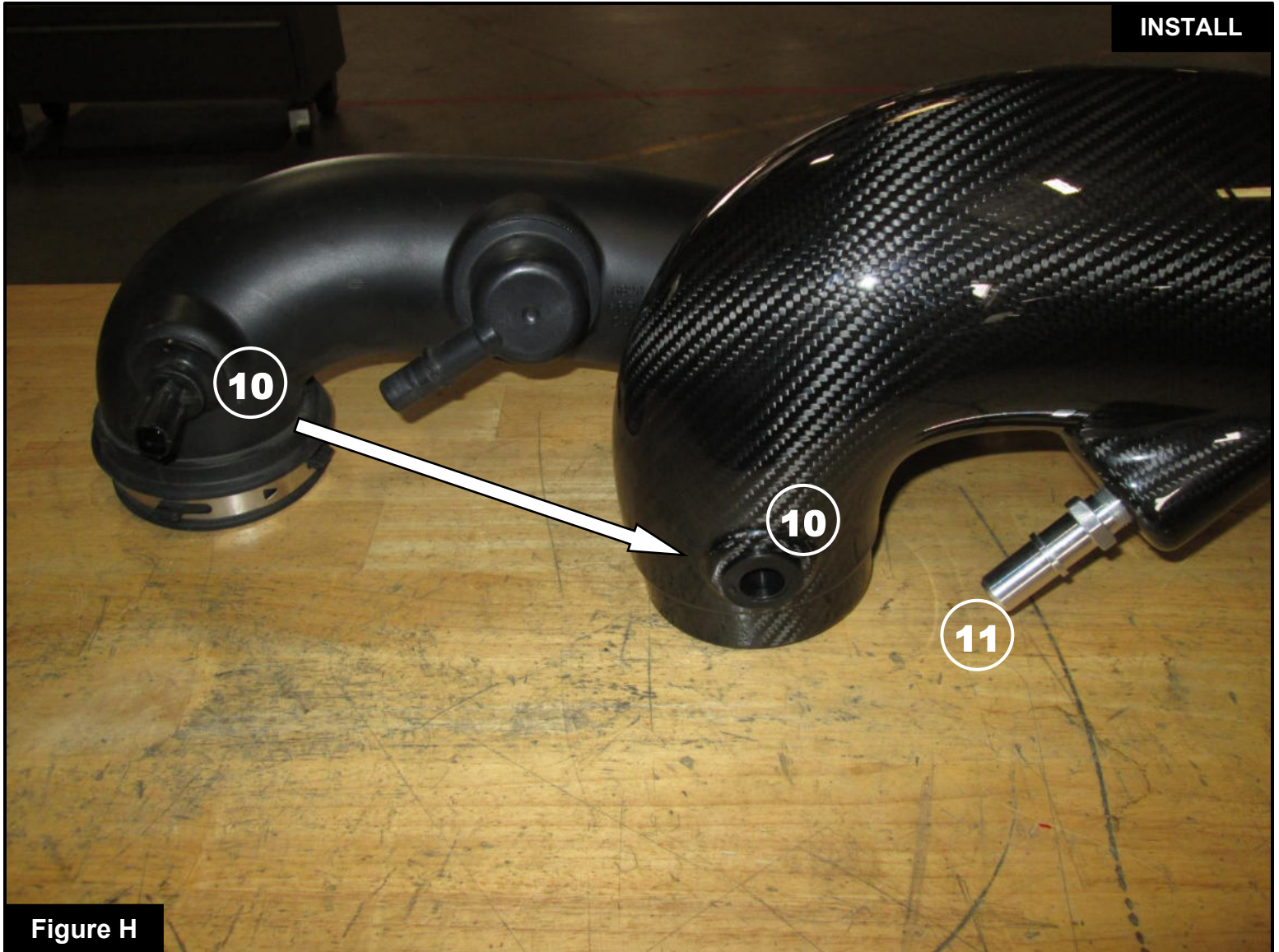
**Figure H****Refer to Figure H for Steps 11-12**

Step 11: Remove the temperature sensor (10) from your factory intake tube by rotating ¼ turn counter-clockwise and gently pulling out from the fitting. Reinstall the sensor into your aFe POWER intake tube by inserting into the plastic fitting and rotating ¼ turn clockwise until it locks into place.

Step 12: Install the supplied aluminum fitting (11) into your aFe POWER intake tube and tighten using a 20mm wrench. **DO NOT OVERTIGHTEN THE FITTING. SOME THREADS WILL STILL BE EXPOSED WHEN FULLY TIGHTENED.**

**Figure I****Refer to Figure I for Steps 13-15**

Step 13: Install your aFe POWER intake tube into the vehicle, sliding the smaller end with the remaining T-bolt clamp into the coupler at the throttle body, then the larger end into your air filter. Tighten both clamps using an 11mm deep socket and ratchet.

Step 14: Reconnect the crank case breather line (12) to the fitting on your intake tube.

Step 15: Reconnect your temperature sensor wire harness (13).

**Figure J****Refer to Figure J for Step 16**

Step 16: Confirm that all connections are secure and clamps tightened. Your installation is now complete.

Thank you for choosing aFe POWER!

NOTE: Check all clamps, and connectors are secure after 100-200 miles



advanced FLOW engineering, inc.

252 Granite Street Corona, CA 92879
TEL: 951.493.7100 • TECH: 951.493.7185
E-Mail: Tech@aFepower.com

P/N: 06-81416