

advanced FLOW engineering

Cold Air Intake System

Instruction Manual P/N: 51-12162-C / 54-12162-C

Make: Dodge

Model: Challenger R/T /Charger R/T

Year: 2011-2021

Engine: V8-5.7L HEMI

Make: Chrysler

Model: 300C

Year: 2011-2021

Engine: V8-5.7L HEMI



- Please read the entire instruction manual before proceeding.
- Ensure all components listed are present.
- If you are missing any of the components, call customer support at 951-493-7185.
- Ensure you have all necessary tools before proceeding.
- Do not attempt to work on your vehicle when the engine is hot.
- Disconnect the negative battery terminal before proceeding.
- Retain factory parts for future use.

Label	Qty.	Description	Part Number
A1	1	Pro DRY S Air Filter	21-91035 (Gray Media)
A2	1	Pro 5R Air Filter	24-91035 (Blue Media)
B	1	Housing	05-12172B3
C	1	Tube	05-12162C1
D	1	Male/Female Isolation Mount	03-50206
E	1	Washer, Lock	03-50071
F	3	Screw, Hex Hd: M6x1x12	03-50032
G	3	Washer, Flat	03-50070
H	1	Clamp, T-Bolt (4-1/8" - 4-1/2")	03-50262
I	1	Clamp, T-bolt (3-9/16"-3-7/8")	v03-50498
J	1	Isolation Pad	03-50196
K	1	Coupling, Silicone Reducer	05-01358
L	1	Trim, Rubber Edge (13")	05-00149
M	1	Seal, Trim (25")	05-00072
N	1	Seal, Trim (17")	05-00072
O	1	Threadlocker	03-50162
P	1	Mini Clamp #10	03-50078
Q	1	Silicone Hose (10.5")	03-50162

Warranty Information available at: <https://afepower.com/contact#warranty>

Note: Legal in California for use on race vehicles only. The use of this device on vehicles used on public streets or highways is strictly prohibited in California and others states that have adopted California emission regulations.

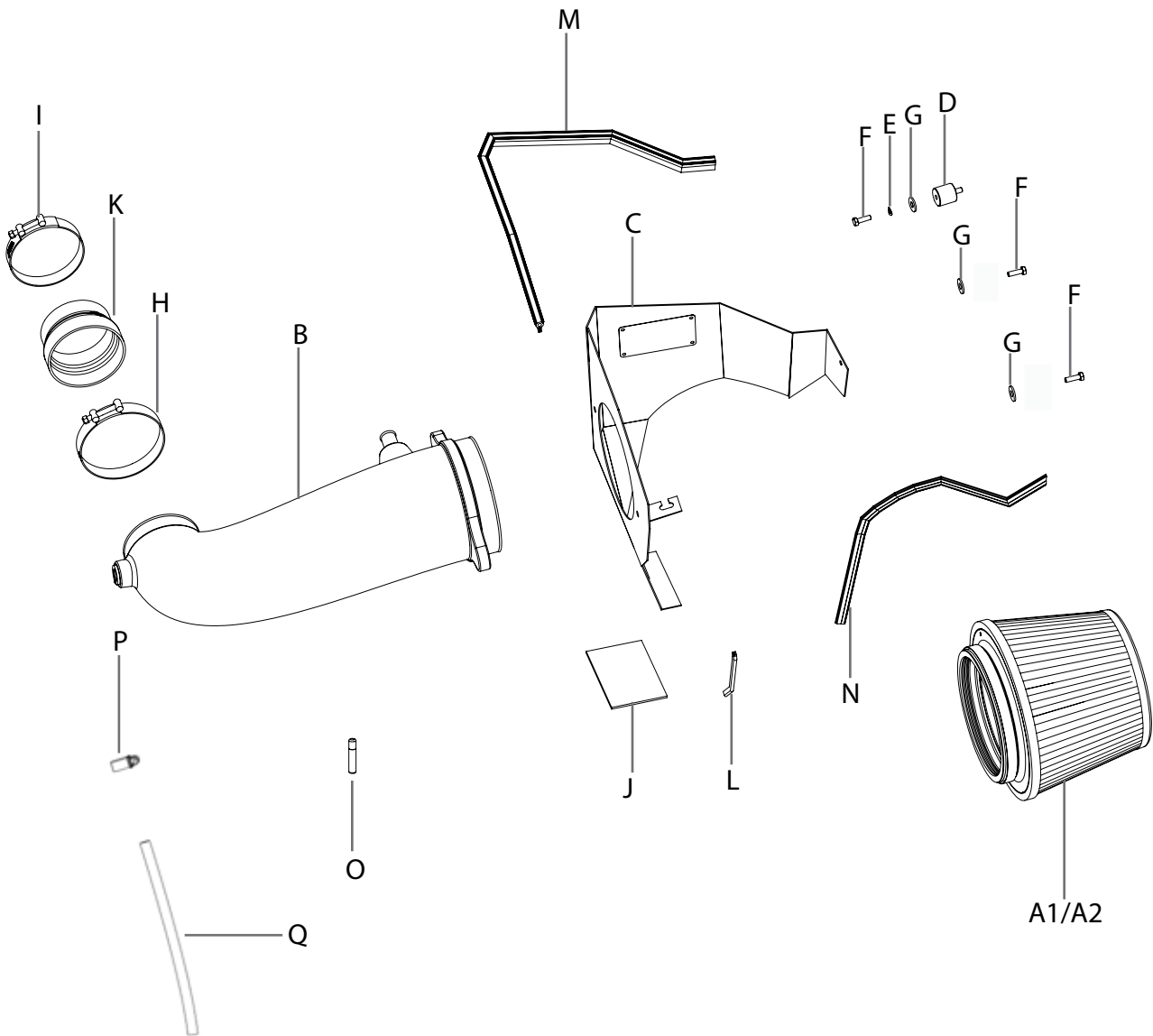



Figure A

Refer to Figure A for Steps 1-6

Step 1: Remove engine cover.

Step 2: Remove 8mm bolt securing the factory air box, this bolt will be reused to secure the aFe housing.

Step 3: Loosen clamp securing the factory intake tube to throttle body.

Step 4: Unplug the Temp sensor connector.

Step 5: For 2011 to 2019 models disconnect the crank case hose from the intake tube, for 2020+ models remove the crank case hose from the vehicle completely.

Step 6: Remove factory air intake system from engine bay.



Figure B

Refer to Figure B for Steps 7-8

Step 7: Remove 10mm bolt from fender side, it will not be reused.

Step 8: Install isolation mount onto fender well.



INSTALL



Figure C

Refer to Figure C for Steps 9-11

Step 9: Remove grommet and metal sleeve from factory housing and install on aFe housing.

Step 10: Install the provided seal trim onto the outer edges of the aFe housing, and install foam pad on the car where the bottom of the housing rests.

Step 11: Install housing onto vehicle. Using (1) provided 10mm bolt, lock washer, and flat washer secure the housing to the isolation mount installed in Step 7. Put the factory 8mm bolt removed in Step 1 back in its original location.



Figure D

Refer to Figure D for Step 12

Step 12: Install silicone coupling and clamps onto throttle body. Make sure clamps are oriented as shown in the photo. Tighten the smaller clamp only.



Figure E

Refer to Figure E for Steps 13-16

Step 13: Remove the temp sensor from the factory tube and install it the aluminum fitting on the aFe tube.

Step 14: Install tube onto vehicle by pushing it into the silicone coupling at the throttle body.

Step 15: Use the remaining two 10mm screws and flat washers to secure the tube to the housing. Apply a little bit of the furnished threadlocker on the screws thread before installation to secure it properly.

Step 16: Tighten larger clamp on the throttle body coupler.



Figure F

### Refer to Figure F for Steps 17-20

Step 17: Reconnect the harness to the Temperature sensor.

Step 18: For 2011-2019 models connect the factory crank case hose to the aFe Power tube, for 2020+ models connect the provided hose to the aFe POWER tube and secure it on the engine side using the provided clamp.

Step 19: Install filter onto intake tube and tighten the filter clamp.

Step 20: Reinstall the engine cover and your install is complete.

NOTE: Check all bolts, clamps, and connectors after 100-200 miles.



PAGE LEFT BLANK INTENTIONALLY

PAGE LEFT BLANK INTENTIONALLY



advanced FLOW engineering, inc.  
252 Granite Street Corona, CA 92879  
<https://afepower.com/contact>