

***advanced FLOW engineering*** Track Series Cold Air Intake System

**Instruction Manual** P/N: 57-10014D / 57-10014R

Make: Jeep Model: Grand Cherokee (WK2) SRT Year: 2012-2021 Engine: V8-6.4L  
Make: Dodge Model: Durango SRT Year: 2018-2021 Engine: V8-6.4L



- Please read the entire instruction manual before proceeding.
- Ensure all components listed are present.
- If you are missing any of the components, call customer support at 951-493-7185.
- Ensure you have all necessary tools before proceeding.
- Do not attempt to work on your vehicle when the engine is hot.
- Retain factory parts for future use.

Label	Qty.	Description	Part Number
A1	1	Air Filter (Pro DRY S)	21-90120
A2	1	Air Filter (Pro 5R)	24-90120
B	1	Tube	05-5710014C1
C	1	Housing	05-5710014B2
D	1	Coupling, Silicone Bellow	05-01555
E	1	Clamp, T-bolt (4-1/16" - 4-3/8") (SS)	03-50262
F	1	Clamp, T-bolt (3-9/16" - 3-7/8") (SS)	03-50498
G	1	Seal, Trim: 3/4" Bulb, 32" Length	05-01507
H	1	Hose, 5/8" ID, 7" Length	05-01502
I	2	Spring Clamp	03-50646

**Installation will require the following tools:**

8mm nut driver or socket, socket wrench, flat-head screwdriver, pliers, and panel popper.

Warranty information available at <https://afepower.com/contact#warranty>.

**Emissions Disclaimer:**

This product is not currently CARB exempt and is not available for purchase in California or for use on any vehicle registered with the California Department of Motor Vehicles.

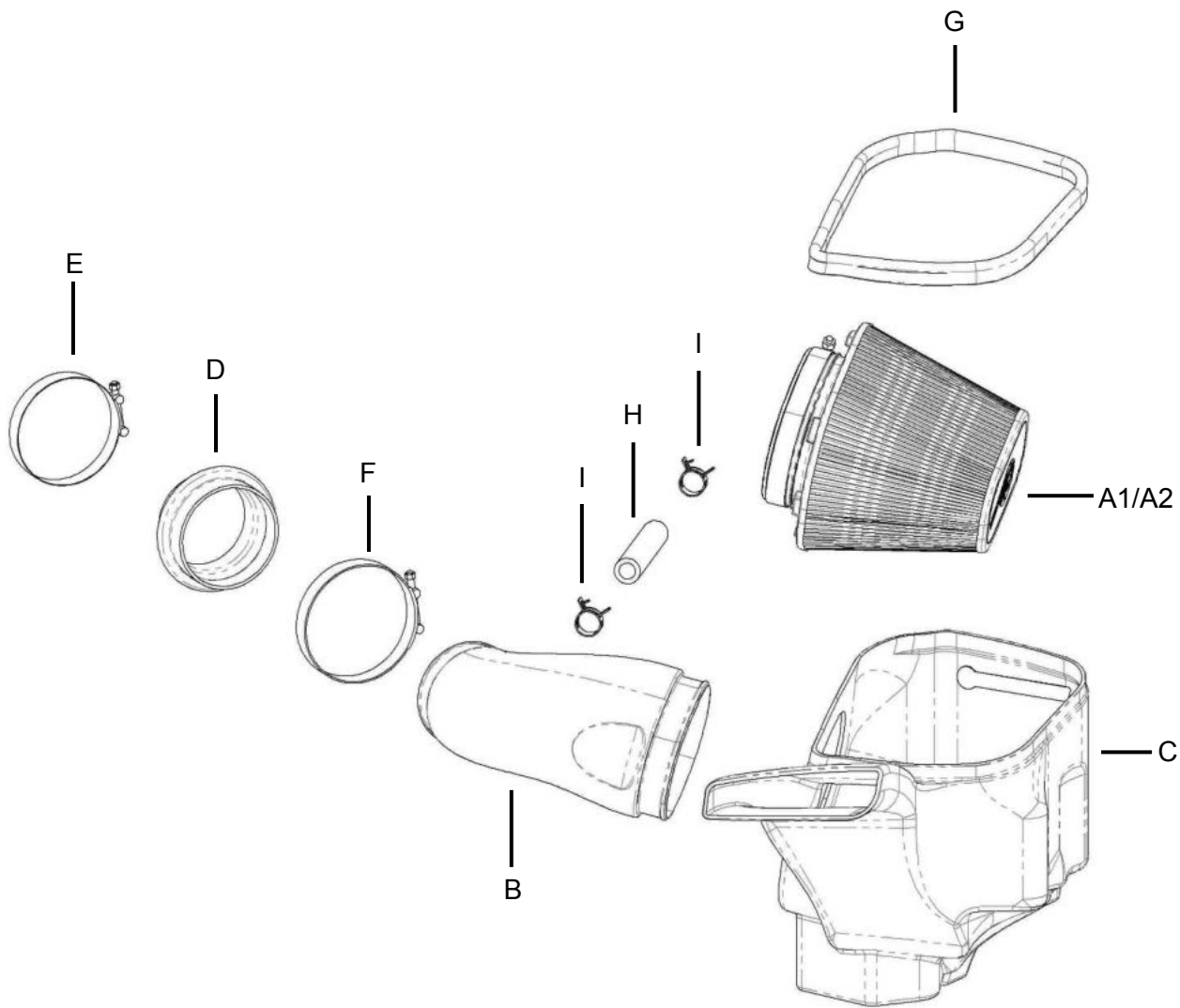

**Figure A****Refer to Figure A for Steps 1-3**

Step 1: Disconnect the temperature sensor.

Step 2: Using an 8mm nut driver, loosen the hose clamps at the throttle body.

Step 3: Remove the driver's side valve cover.

**Figure B****Refer to Figure B for Steps 4-5**

Step 4: Disconnect the crankcase vent (CCV) line from the engine and pull the hose away from the engine.

This hose will be replaced.

Step 5: Remove the factory intake. Carefully, pull the factory intake tube away from the throttle body and pull up on the factory airbox.

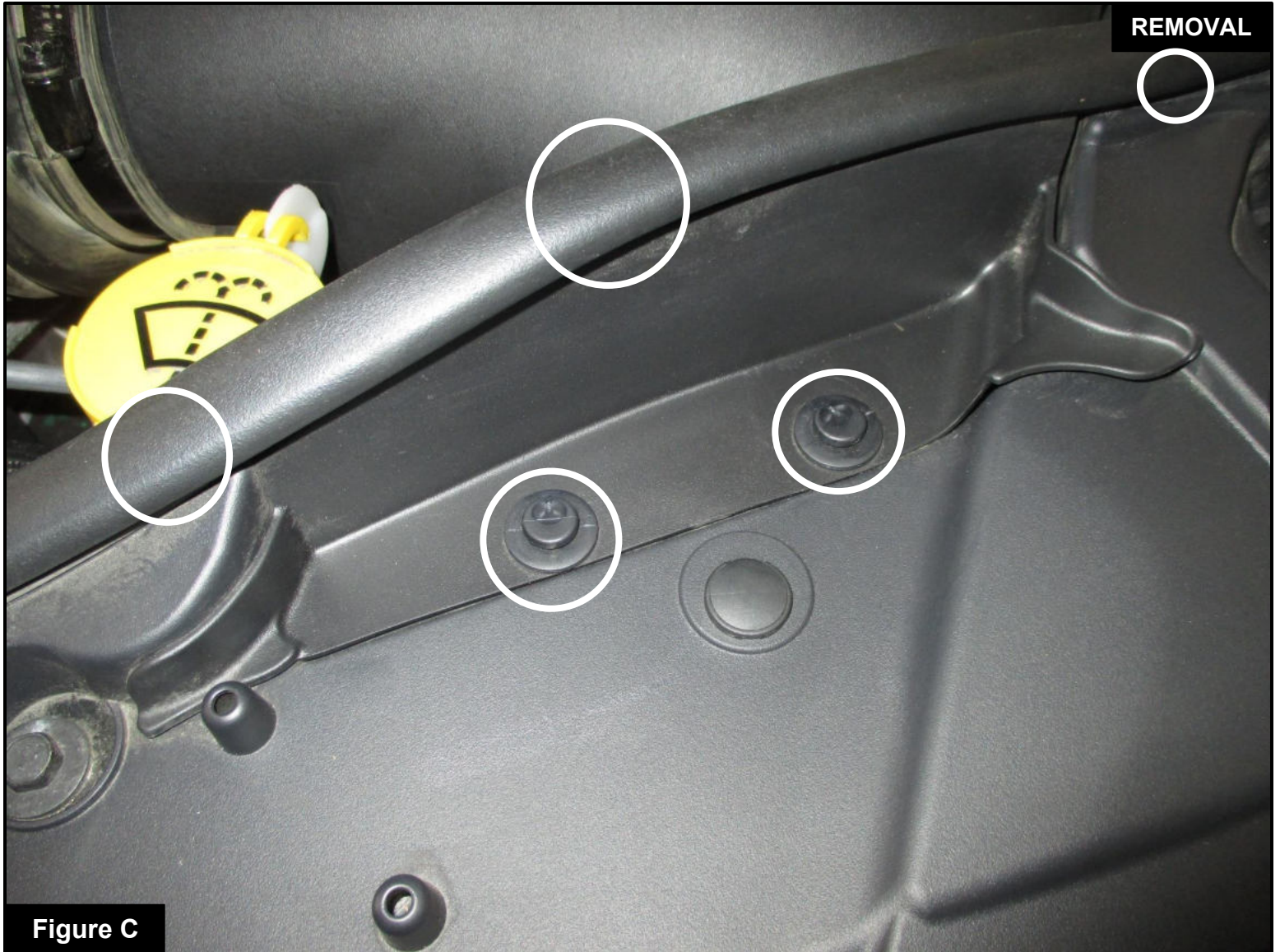
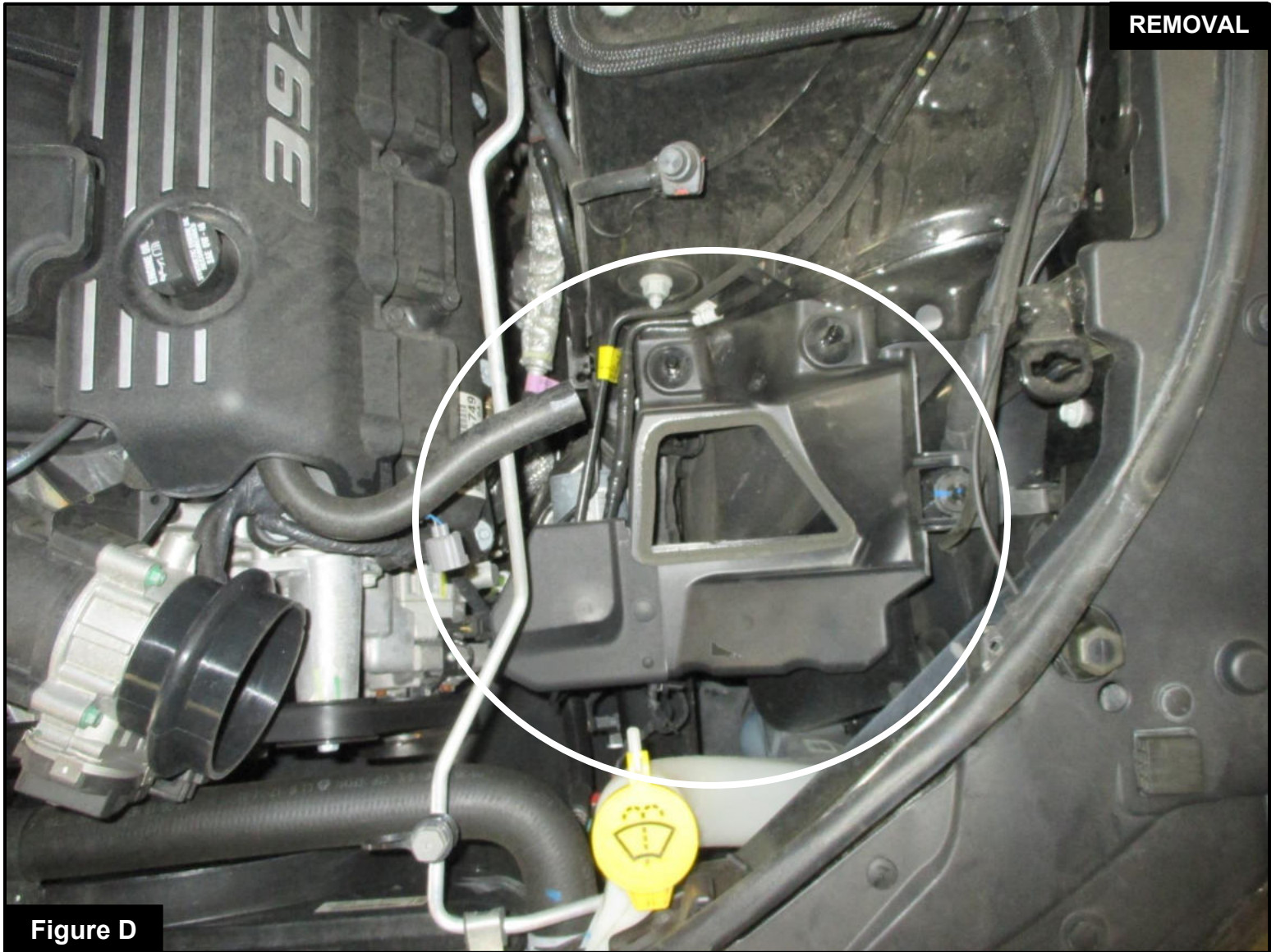

Figure C

**Refer to Figure C for Step 6**

Step 6: Remove the factory block off plate. Use a panel popper to remove the two (2) pins and three (3) clips from the factory trim seal.



**Refer to Figure D for Step 7**

Step 7: Remove the factory panel from the vehicle.



Figure E

**Refer to Figure E for Step 8**

Step 8: Install the supplied coupling and clamps onto the throttle body. Do not tighten the clamps.



Figure F

**Refer to Figure F for Step 9**

Step 9: Transfer the three (3) factory grommets from the factory airbox to the aFe POWER housing.

**Figure G****Refer to Figure G for Steps 10-12**

Step 10: Install the supplied air filter into the aFe POWER housing. Place the air filter into the large opening at the top, then slip the air filter mouth into the oval opening on the aFe POWER housing, making sure the air filter's lip locks into place.

Step 11: Place the clamp over the flange of the air filter and position it as shown in Figure F. Do not tighten at this time.

Step 12: Install the supplied trim seal on the top edge of the aFe POWER housing.

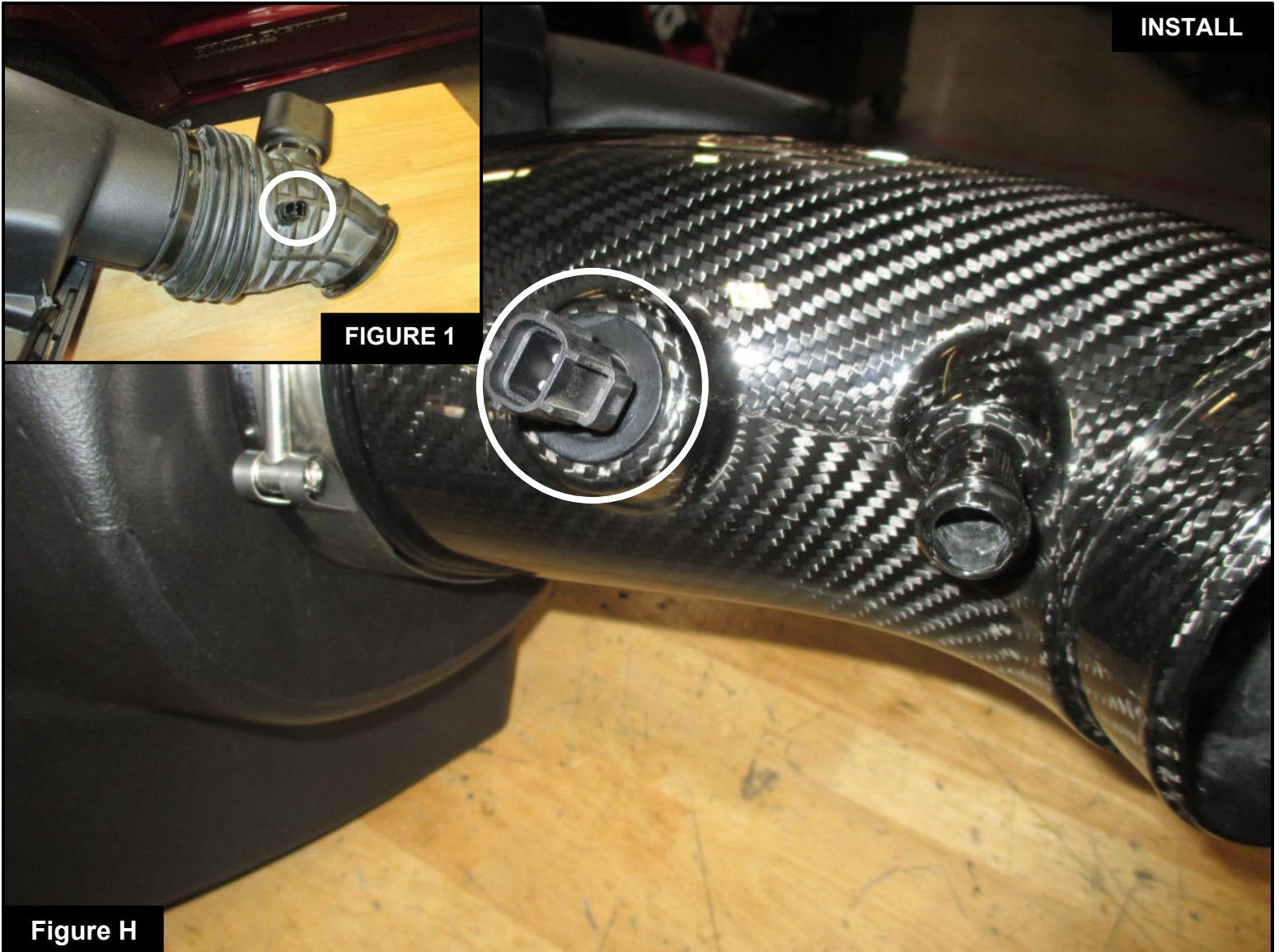
**Figure H**

### **Refer to Figure H for Steps 13-14**

Step 13: Transfer the temperature sensor from the factory intake tube to the aFe POWER intake tube.

Carefully pull up on the sensor to remove from the factory intake. Then, install the sensor into the aFe POWER intake tube by pushing it into the fitting and rotating clockwise quarter-turn, keeping it from sliding out.

**NOTE: Keep the factory O-ring installed on the temperature sensor to provide an air seal.**

Step 14: Insert the aFe POWER intake tube into the pre-assembled aFe POWER housing and air filter. Do not tighten the clamp at this time.



Figure I

**Refer to Figure I for Step 15**

Step 15: Install the supplied hose and one (1) supplied clamp onto the engine's CCV opening.

**Figure J****Refer to Figure J for Steps 16-19**

Step 16: Install the assembled aFe POWER intake into the engine bay by gently pushing the housing in to the three (3) mounting pins. Slide the aFe POWER intake tube into the coupling at the throttle body.

Step 17: Slip the aFe POWER intake tube into the coupling. Do not tighten the clamp at this time.

Step 18: Align the aFe POWER housing to the opening from **Step 6**.

Step 19: Connect the open end of the supplied hose from **Step 15**. Use the remaining supplied clamp (Label "1") to tighten to the aFe POWER intake tube.

**Figure K****Refer to Figure K for Steps 20-24**

Step 20: Connect the temperature sensor harness to the temperature sensor.

Step 21: Tighten the clamps between the aFe POWER intake tube and the coupling and air filter.

Step 22: Re-install the factory valve cover.

Step 23: Re-attach the factory trim seal from **Step 6** and attach to the aFe POWER housing.

Step 24: Make sure all components and connections are secure. Your installation is now complete. Thank you for choosing aFe POWER!

**NOTE: Check all bolts, clamps, and connectors after 100-200 miles.**



**Page left blank intentionally.**



***advanced FLOW engineering, inc.***

252 Granite Street Corona, CA 92879

<https://afepower.com/contact>