

**advanced FLOW engineering** Track Series Cold Air Intake System

**Instruction Manual** P/N: 57-10018D / 57-10018R

Make: Chevrolet

Model: Camaro ZL1

Year: 2017-2021

Engine: V8-6.2L (sc) LT4



- Please read the entire instruction manual before proceeding.
- Ensure all components listed are present.
- If you are missing any of the components, call customer support at 951-493-7100.
- Ensure you have all necessary tools before proceeding.
- Do not attempt to work on your vehicle when the engine is hot.
- Retain factory parts for future use.

Label	Qty.	Description	Part Number
A1	1	Air Filter (Pro 5R)	24-90112
A2	1	Air Filter (Pro DRY S)	21-90112
B	1	Tube	05-5710018C1
C	1	Housing	05-5710018B2
D	1	Scoop	05-74210B3
E	1	Coupling, Silicone Bellow	05-01605
F	1	Fitting, SAE 9.89 to 1/8" NPT	05-01692
G	2	Clamp, T-bolt (3-13/16" - 4-1/8") (SS)	03-50265
H	1	Seal, Trim: 13/32" dbl. Bulb (32"L)	05-01534
I	2	Screw, Torx: M4x8mm	03-50491

**Installation will require the following tools:**

T-20 Torx driver, 8mm nut driver, 11mm deep socket & driver, 15mm wrench or adjustable wrench

Warranty Information available at <https://afepower.com/contact#warranty>

**Emissions Disclaimer:** This product is not currently CARB exempt and is not available for purchase in California or for use on any vehicle registered with the California Department of Motor Vehicles.

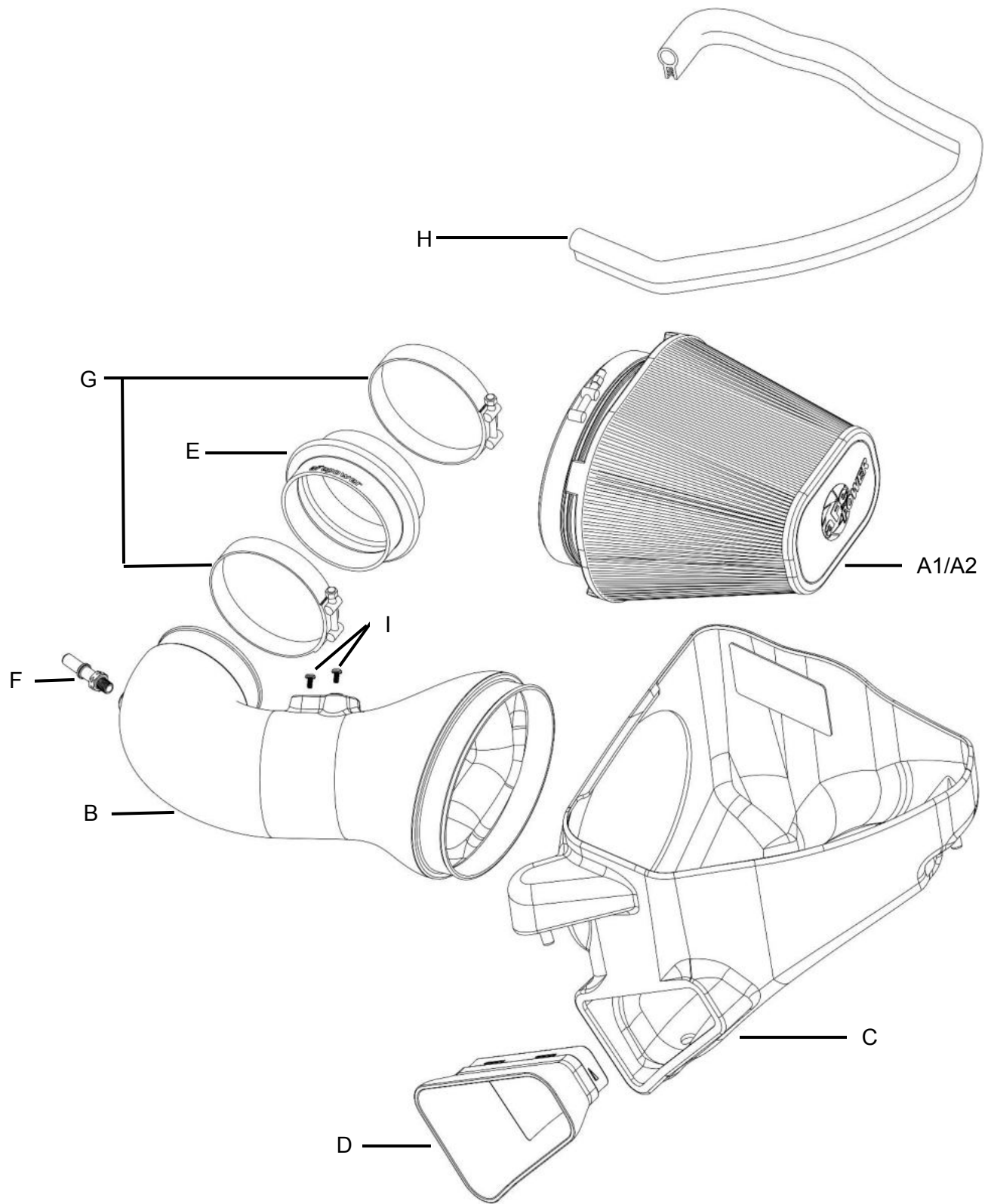



### **Refer to Figure A for Steps 1-4**

Step 1: Disconnect the mass air flow sensor (1) and the wiring harness clip (2).

Step 2: Disconnect the breather hose (3) from the intake tube.

Step 3: Use an 8mm nut driver to loosen the stock clamps (4) at the throttle body and the airbox.

Step 4: Remove the stock intake tube.

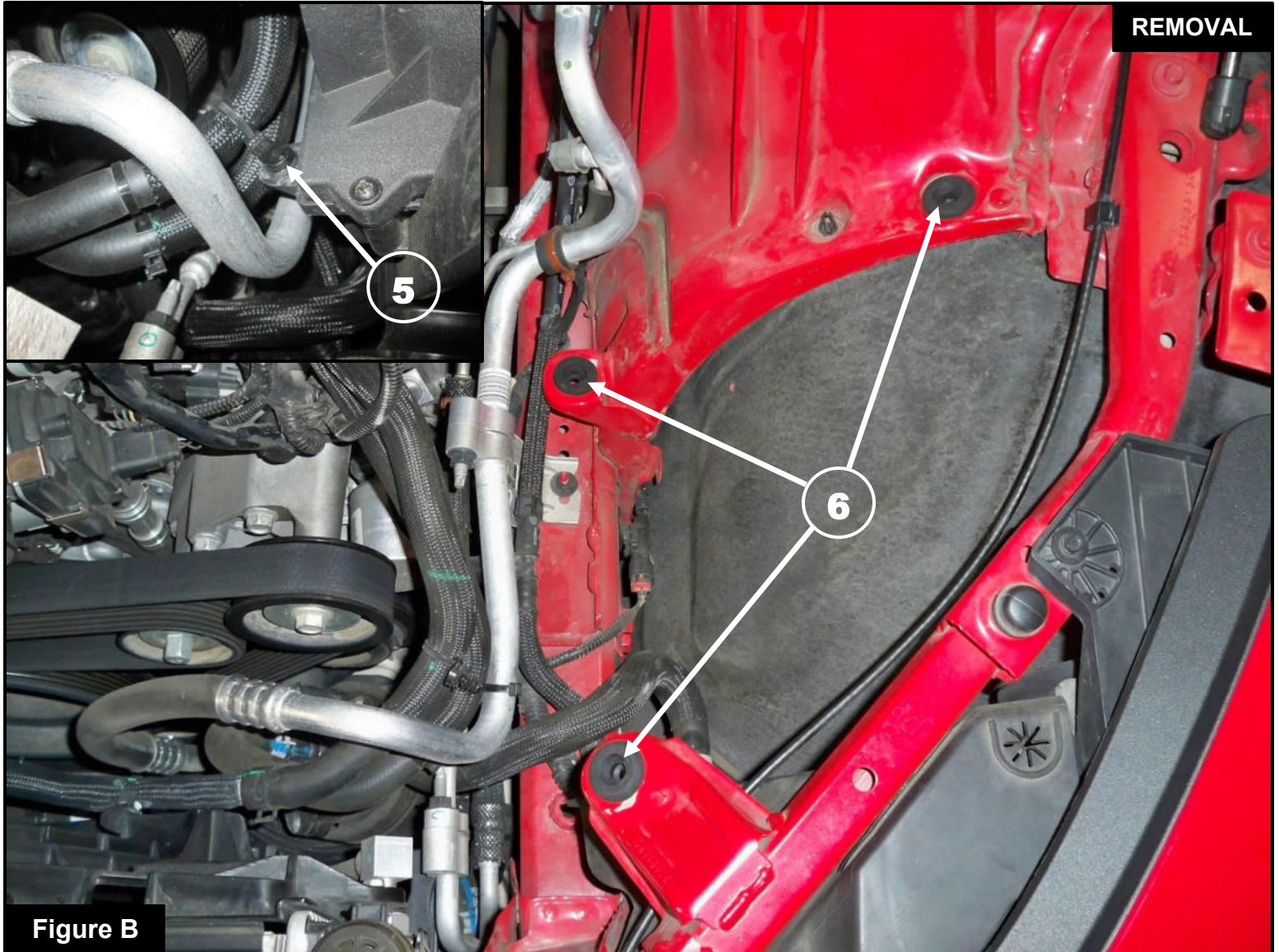

Figure B

**Refer to Figure B for Steps 5-6**

Step 5: Remove the clip (5) holding the coolant line to the airbox.

Step 6: Remove the airbox by pulling up to release from its mounting grommets (6). Make sure the mounting grommets are still in the chassis mounting tabs. If they pulled out and are stuck in the lower half of the airbox, remove them from the airbox and insert them back on the chassis mounting tabs.

**Figure C****Refer to Figure C for Steps 7-8**

Step 7: Using a Torx T20 driver, remove the mass air flow sensor (7) from the upper half of the airbox and install it into the aFe POWER intake tube using the two provided M4 torx screws.

Step 8: Install the supplied aluminum vent fitting (8) into the aFe intake tube using a 15mm wrench or adjustable wrench.



Figure D

**Refer to Figure D for Steps 9-11**

Step 9: Install the supplied air inlet scoop (9) into the aFe POWER housing.

Step 10: Install the aFe POWER housing assembly into the vehicle by pushing down the housing pins into the mounting grommets. Make sure the pins are completely through the mounting grommets and the scoop is in the rubber inlet opening cavity.

Step 11: Install the seal trim (10) on the top opening of the aFe POWER housing as shown. Trim to fit.



Figure E

**Refer to Figure E for Step 12**

Step 12: Remove the filter clamp (11) from the aFe POWER filter. Slide the aFe POWER filter into the aFe POWER housing from the top. Then guide the filter flange through the oval opening in the housing and snap in the filter. Place the filter clamp on the filter flange.

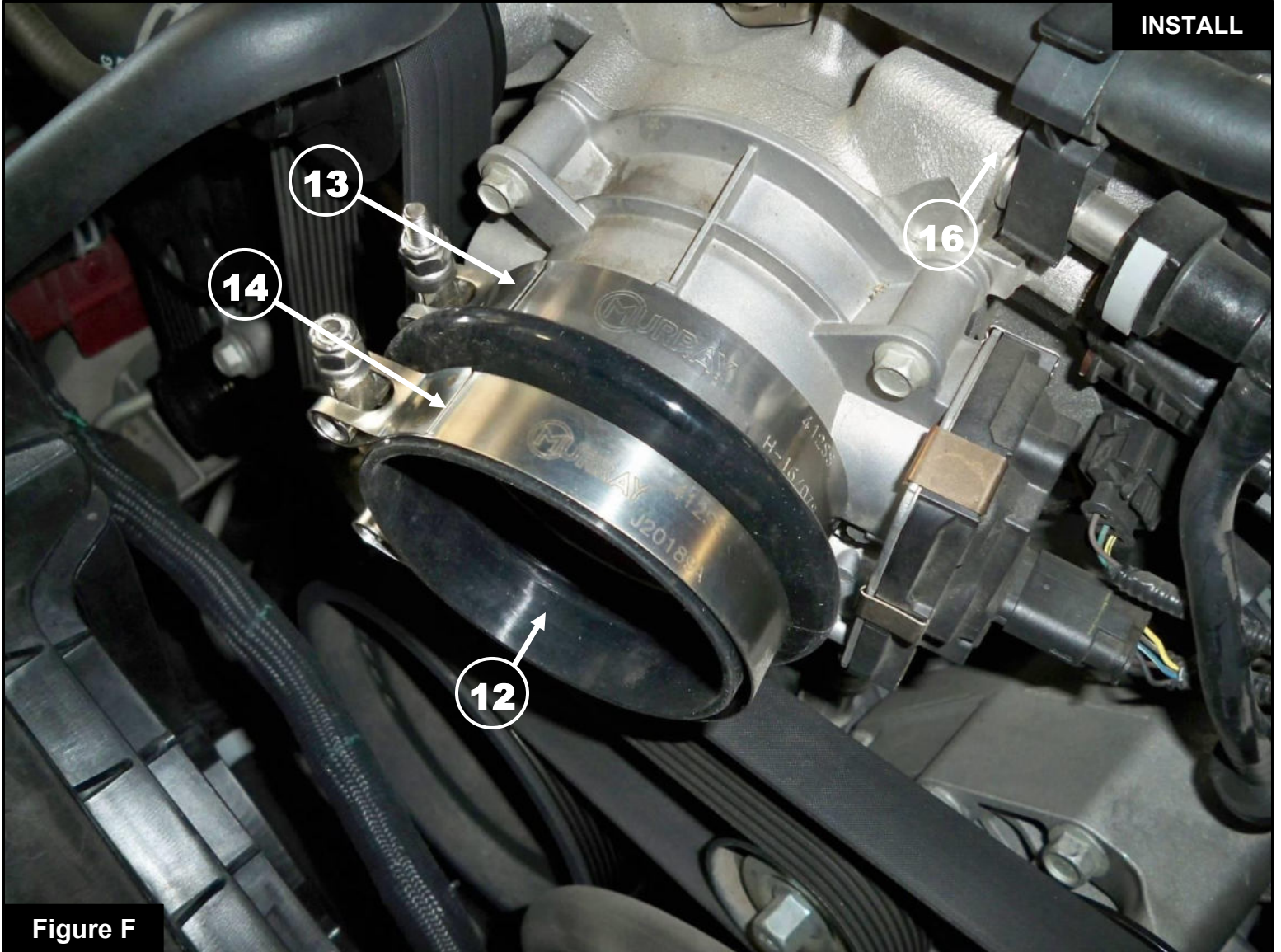
**Figure F**

**Refer to Figure F for Steps 13-14**

Step 13: Install the supplied silicone coupling (12) onto the throttle body with the supplied clamp (13) as shown and tighten the clamp using an 11mm deep socket and driver.

Step 14: Place the other supplied clamp (14) on the silicone coupling as shown. Do not tighten this clamp.



**Figure G**

**Refer to Figure G for Steps 15-16**

Step 15: Install the aFe POWER intake tube into the vehicle. Slide the tube into the throttle body coupling first, then into the air filter.

Step 16: Align the aFe POWER intake tube and clamps correctly, then using a 11mm deep socket and driver tighten all the clamps.

**Figure H****Refer to Figure H for Steps 16-17**

Step 17: Connect the mass air flow sensor (15) and breather hose (16).

Step 18: Check all the components are tight and secure. Your installation is now complete. Thank you for choosing aFe POWER!

**NOTE: Check all bolts, clamps, and connectors after 100-200 miles.**



***advanced FLOW engineering, inc.***

252 Granite Street Corona, CA 92879  
TEL: 951.493.7100 • TECH: 951.493.7134  
E-Mail: Tech@aFepower.com

P/N: 06-81445